

DRYPIX
7000

Fuji Medical Dry Laser Imager

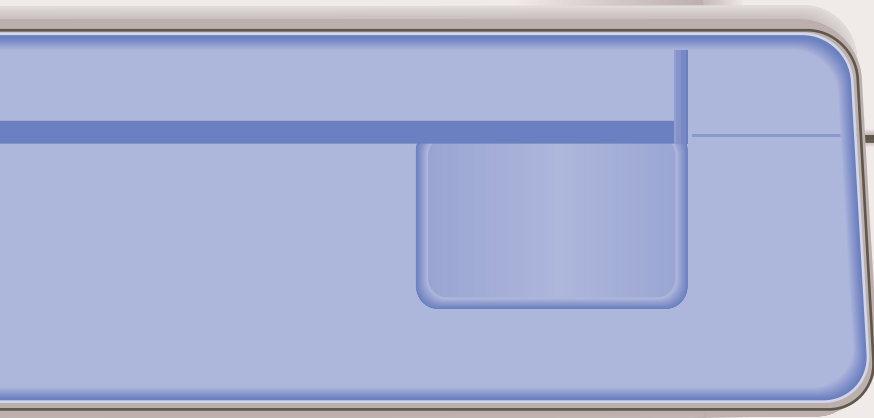

 **FUJIFILM**



DRYPIX
7000



Wet Imager Performance from a Dry Imager

Series flagship boasts outstanding performance, speed and quality – plus the bonus of “networkability”

The newest addition to the DRYPIX family of dry imagers rates flagship status with features such as remarkable operating efficiency, highest film throughput, backup security and unrivalled image quality, while maintaining the lowest cost of ownership. An integral part of our new DRYPIX Print Networking System, the DRYPIX 7000's networking capabilities set new standards for convenience and versatility.

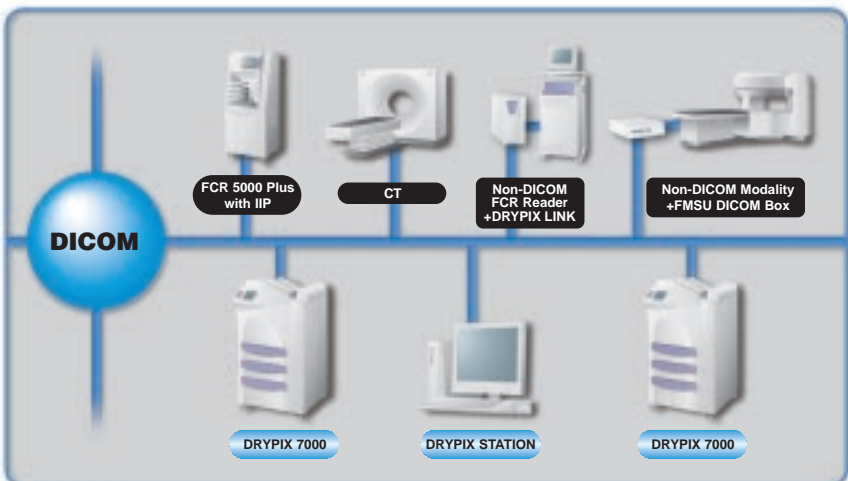

Dry Laser Imaging System

The DRYPIX 7000's Dry Laser Imaging System uses a photo-thermographic process, which combines laser exposure and thermal development. The photosensitive film is exposed to an ultra-precise laser, which is modulated according to the input data to form a latent image. The film is then uniformly heated in the thermal development section of the imager, which uses unique Fuji thermal element technology, which is more precise and requires less maintenance than conventional drum technology. Operating costs and efficiency benefit from the elimination of wet chemicals and their environmental implications.

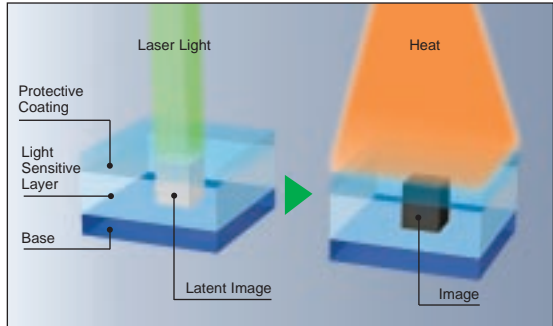

Advanced Variable Response (A-VR) Spline Interpolation

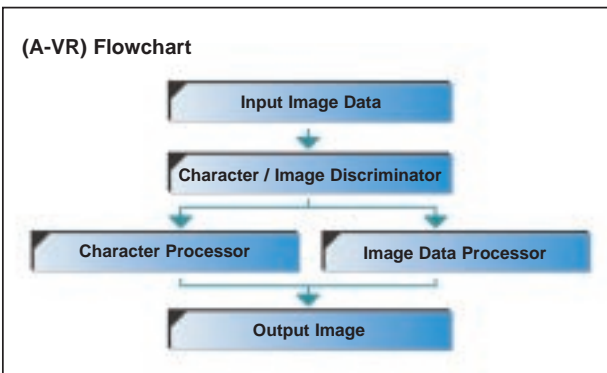

DRYPIX 7000's imaging process utilizes Fujifilm's A-VR interpolation algorithms to magnify or reduce medical diagnostic images read from modalities, generating film pages in a variety of formats. A-VR automatically detects and distinguishes

between image data and alphanumeric characters, ensuring clear, sharp alphanumerics even when noisy images require smooth interpolation of image data. Benefits include easier, faster, more accurate diagnosis.

Smooth Curve Arranging (SAR)

Smooth Curve Arranging offers gray scale reproduction individually optimized not only for each modality such as Ultrasound, CT, MR or Computed Radiography, but also allows adjustment of gray tones to best match the diagnostic needs of individual Radiologists. Individual SAR tables have also been developed specifically to ensure precise optimization of image output from individual manufacturers' equipment.

Automatic Self-Calibration

DRYPIX 7000 prints a 24-step gray scale pattern to film and measures the densities of all 24 steps using an internal densitometer. A feedback system automatically compares these densities with control values and makes any necessary adjustments. A barcode reader in the film drawer automatically initiates an Auto Film Density Correction (FDC) when a new batch of film is loaded.



"Image Intelligence" is a set of sophisticated digital image-processing software technologies that are incorporated in the DRYPIX 7000.

DI-HL and DI-HLc Films

Contributing to DRYPIX 7000's consistently high image quality and high throughput are new DI-HL (Blue Base) and DI-HLc (Clear Base) films. Their clear images with low minimum density and neutral image tone are comparable to those from conventional wet laser imagers. The new films are available in 14"x17", 25.7x36.4 cm (10"x14") and 8"x10" sizes.



Optional Sorter and Film Drawers

DRYPIX 7000 can be configured with up to three film drawers allowing for multiple film sizes on-line. An optional 10-bin film sorter is available for added efficiency. Sorting can be done by modality or patient study.

DRYPIX LINK

DRYPIX LINK allows older non-DICOM compliant FCR Readers to connect to DICOM networks by converting proprietary digital data into DICOM. Print jobs from DRYPIX LINK can be sent to multiple print targets with automatic fail-over if the primary imager is off-line.



DICOM Box

The DICOM Box connects non-DICOM modalities, sending image data to the DRYPIX 7000 through the DICOM network. "All Options" DICOM Boxes enhance network capability by adding DICOM Store and Worklist Management capabilities to older non-DICOM modalities.



DRYPIX STATION

DRYPIX STATION Print Manager provides automatic fail-over capability for all DICOM imagers on a print network and ensures printing continuity. In addition, print job management and spooling can be done at the DRYPIX STATION. In combination with DRYPIX LINK, DRYPIX STATION Image Manager provides DICOM Store and Worklist Management capabilities to older non-DICOM FCR Readers.



Increased Department Efficiency and Revenue

Robust design parameters learned from Fujifilm's extensive experience in dry imaging ensure the DRYPIX 7000 continues the exceptional reliability record of Fuji DRYPIX Imagers. This, combined with the automatic fail-over capability provided by the optional DRYPIX STATION ensures printing continuity. Able to meet the needs of the busiest Radiology department, DRYPIX 7000's laser exposure, thermal development system can handle up to 180 14"x17" films per hour with initial film output in just 65 seconds, and with absolutely no compromise in image quality.

Lowest Cost of Ownership

The exceptional reliability and fail-over capability of the DRYPIX 7000 and DRYPIX Print Networking System almost eliminate downtime and drastically reduce service costs. In addition, economical equipment and film pricing provide the lowest cost of ownership over the lifetime of the imager. Since the DRYPIX 7000 can handle up to three film sizes, film costs can be further reduced by printing small images on less costly small film sizes.

Enhanced Diagnostic Capabilities

Fujifilm's extensive experience in dry imaging allows the DRYPIX 7000 to consistently deliver superior quality with extremely high throughput. Fuji Image Intelligence™ digital image processing software technologies such as Advanced Variable Response (A-VR) spline interpolation and Smooth Curve Arranging (SAR) ensure DRYPIX 7000 images are specially optimized for each modality. DRYPIX 7000 prints to the edges of the film, producing true size images without cropping.



•Backup Security

Optionally available DRYPIX STATION assures system reliability in multi-unit environments by automatically detecting when the primary print target is off-line and re-routing images to an active secondary imager.

•Easy Operation

DRYPIX 7000's newly developed color, touch-screen operation panel with icon-based interface and animated instructions simplifies operation and reduces operator error. All operations, from film loading to processing, are carried out in daylight room conditions.



•Networkable and Connectable

With a built-in high-speed DICOM Print Server, connection is fast and error-free, allowing fast communication with any DICOM Print compliant modality on the network.

• Centralized Printing

DRYPIX 7000's robust design with high throughput, backup security, multiple film sizes and sorting capability make it ideal as a centralized imager, maximizing the efficiency of a centralized multi-modality network.

Fuji Medical Dry Laser Imager DRYPIX 7000 Specifications

Recording method:	Laser exposure thermal development system
Applicable film:	Fuji Medical Dry Imaging Film DI-HL (Blue Base) / DI-HLc (Clear Base) 14" x 17" (35.6 x 43.2 cm), 10" x 14" (25.7 x 36.4 cm) or 8" x 10" (20.3 x 25.4cm)
Film loading:	Daylight film loading
Film trays:	Up to 3 trays*
Processing capacity:	180 sheets/hour (14" x 17"), 240 sheets/hour (25.7 x 36.4cm), 200 sheets/hour (8" x 10")
Time required for first output:	Approx. 65 sec. (14" x 17" film size)
Gray scale resolution:	14 bits
Pixel size:	100/50 microns is selectable for all sizes**
Input channels:	One network channel
Image memory:	Standard 256MB (512MB Optional)
Density adjustment:	Automatic density correction
Optional sorter bins:	10 bins
Physical Characteristics	
External dimensions	(W x D x H): 29" x 27" x 49" (735 x 680 x 1240mm)
Weight (with one tray):	448 lbs. (203kg)
Power supply:	AC 200-240 V
Phase:	single 50-60Hz 12A

Operating Environment

Temperature:	59°F -86°F
Humidity:	40-70% (at 59°F), 15-70% (at 86°F) (No dew condensation)

* Configurable based on user requirements.
 ** 50 micron for high resolution printing.
 Note: Specifications are subject to change without notice.
 Consult your local Fujifilm representative for details of models and types.

Dimensions

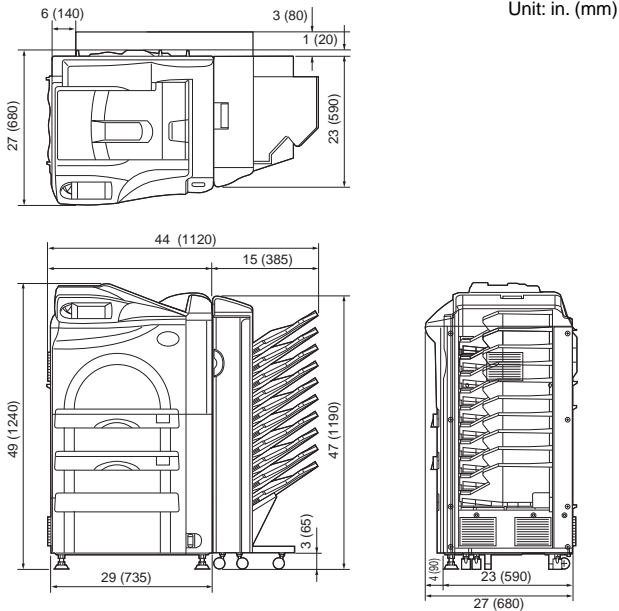

FUJIFILM Medical Systems USA, Inc.

Corporate Headquarters

419 West Avenue
 Stamford, CT 06902-6300
 203-324-2000
 800-431-1850

29012 N. Hancock Parkway
 Bldg 7
 Valencia, CA 91355-1007
 866-533-FUJI (3854)

2001 Westside Parkway
 Suite 165
 Alpharetta, GA 30004-7408
 770-346-0120
 888-699-FUJI (3854)

1055 Stevenson Court
 Roselle, IL 60172-2300
 630-582-2202
 800-323-2546

www.fujimed.com