

Christie CP2210

Digital cinema projection
Color correction/Timing rooms
Digital intermediate suites
Executive screening rooms
Post production



Powerful. Compact. Reliable.

The Christie® CP2210 is the most compact digital cinema projector in the world and the projector of choice for the world's leading post production facilities and exhibitors where booth space is at a premium. Coming from a heritage in cinema, we know what it takes to keep production and installation schedules on track. The reliability of our solutions mean that in the most critical situations, you can depend on Christie.

As part of the Christie Solaria® Series of digital cinema projectors, the Christie CP2210 is based on Texas Instruments' Series 2 DLP Cinema® technology and is compliant with the Digital Cinema Initiatives (DCI) specification.

*Now available with Christie Previsto
High Frame Rate technology*

CHRISTIE®



▲ For screens up to 45 feet



Christie CP2210

127-001102-01

Purpose-built for long-term reliability, the Christie CP2210 is the industry's most compact DCI compliant projector available today. At less than 100 pounds, and with heat extraction optional, this powerful compact projector can be installed nearly anywhere.

Based on 0.98" DLP Cinema technology, the Christie CP2210 uses high efficiency, long lasting CDXL-SD series Xenon lamps as well as the CDXL-14M and CDXL-16M, new lamps designed for long life and low power consumption. The competition requires higher wattage lamps for the same light output, giving Christie clear advantage on cost of ownership and lumens per watt.

A robust and reliable addition, the Christie CP2210 features a motorized lensing solution and a selection of eight zoom lenses to guarantee the right lens solution for virtually any auditorium with absolutely no need for resizing or scaling. It is the projector of choice for small screens and post production applications that demand performance and reliability in a small, affordable package.

Now with Christie Previsto™ High Frame Rate (HFR) technology, your investment is ready for the next evolution of digital cinema. Display premium 2D/3D HFR feature film and alternative content in its original format, giving your audiences the best visual experience possible.

2K, Series 2 DLP Cinema technology

DCI compliant

3D ready

Lowest cost of ownership

Accessories – for easy integration into any environment, Christie's full range of digital cinema accessories includes the Christie Integrated Media Block (IMB), the Christie Cine-IPM 2K for alternative content, the Christie SKA-3D for economical Audio/Video processing, the Christie ACT automation control system, and a full suite of lenses and lamps.

Standard support for HDCP and SNMP

Split power operation for use with UPS

Local control via flexible Touch Panel Controller (TPC) and full access from anywhere via web based GUI

One-piece compact design for flexible mounting and installation

Rear access for quick and easy lamp changes

New Intelligent Lens System (ILS™), custom designed for cinema, for reliable motorized lens operation

In its standard configuration, the Christie CP2210 requires no heat extraction, an optional duct is available if desired

Specifications	CP2210	
Brightness ¹	lamp	<ul style="list-style-type: none"> • 1.4kW (CDXL-14M) 003-003066-01 • 1.6kW (CDXL-16M) 003-003900-01 • 1.8kW (CDXL-18SD) 003-002742-01 • 2.0kW (CDXL-20SD) 003-001976-01
	nominal	• 12,000 lumens
	screen size	• 45' screen ¹
Supported frame rates	<ul style="list-style-type: none"> • 2D up to 120 fps, • 3D up to 60 fps/eye² 	
Contrast ratio	• >2000:1 full field on/off	
Digital micromirror device	<ul style="list-style-type: none"> • 0.98" 2K 3-chip DMD DLP Cinema • 2048 x 1080 pixels 	
Input line voltage	• Single phase 220V	
Number of colors	• 35.2 trillion	
Lenses	• See christiedigital.com	
Power supply	• 1kW-2.1kW low-ripple switch mode lamp power supply	
Weight	• As installed: 96lbs max (43.5kg)	
Accessories	<ul style="list-style-type: none"> • Christie Integrated Media Block (IMB) 108-384107-01 • 90 degree extraction duct adapter 119-103105-01 • Lens blinder kit 119-102101-01 • Rack mount stand 108-416102-01 	

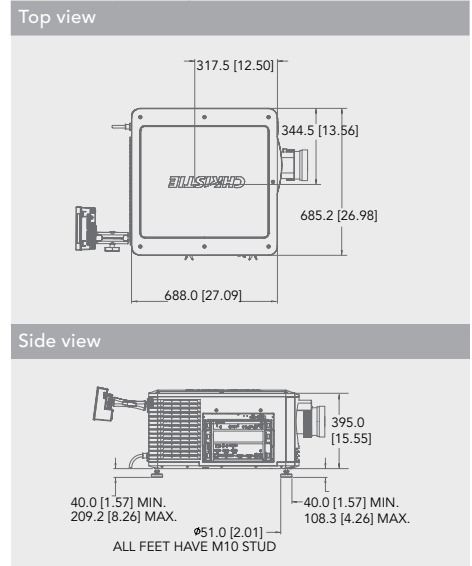

¹ Maximum screen size depends upon various factors such as screen gain, lamp age, geometry, etc. Consult your Christie representative for detailed analysis. Measured at screen center.

² To learn more about high frame rates and the next evolution of digital cinema display see Christie's High Frame Rate technology overview.

Corporate offices

Christie Digital Systems USA, Inc.
USA – Cypress
ph: 714 236 8610

Christie Digital Systems Canada Inc.
Canada – Kitchener
ph: 519 744 8005

Worldwide offices

United Kingdom
ph: +44 (0) 118 977 8000

Germany
ph: +49 2161 664540

France
ph: +33 (0) 1 41 21 44 04

Spain
ph: +34 91 633 9990

Republic of South Africa
ph: +27 (0)11 510 0094

Eastern Europe and
Russian Federation
ph: +36 (0) 1 47 48 100

United Arab Emirates
ph: +971 4 3206688

India
ph: +91 80 6708 9999

Singapore
ph: +65 6877 8737

China (Shanghai)
ph: +86 21 6278 7708

China (Beijing)
ph: +86 10 6561 0240

Japan (Tokyo)
ph: 81 3 3599 7481

Korea (Seoul)
ph: +82 2 702 1601

Independent sales
consultant offices

Italy
ph: +39 (0) 2 9902 1161



DLP Cinema® Technology
2009 Academy Scientific and
Engineering Award for Color Accuracy

A.M.P.A.S.® Recipients of the 2009 Academy Plaque are
D. Scott Dewald, Greg Pettitt, Brad Walker and Bill Werner.



ISO 9001
ISO 14001
Kitchener, Ontario



For the most current specification information, please visit www.christiedigital.com

Copyright 2012 Christie Digital Systems USA, Inc. All rights reserved. All brand names and product names are trademarks, registered trademarks or tradenames of their respective holders. Christie Digital Systems Canada Inc.'s management system is registered to ISO 9001 and ISO 14001. Performance specifications are typical. Due to constant research, specifications are subject to change without notice. Printed in Canada on recycled paper. 3409 Oct 12

CHRISTIE®