



Our technology ■ ■ ■

9000 Series printers offer the best balance between performance and flexibility in their segment for an easy integration in all manufacturing environments. Their state-of-the-art design requires minimal attention and provides high quality coding.

The continuous inkjet technology prints the best before dates, logos, alphanumeric text and 1D and 2D barcodes for food, beverage, pharmaceutical and cosmetic industries.

Your benefits ■ ■ ■

Simplicity – Ergonomic design with an intuitive user interface featuring shortcuts and a direct access to consumables. Compact design and stand mounting option for easy integration into the production line.

Performance – Up to 4-line printing. Print speed up to 4.4 m/s.

Quality – Automatic ink-pressure adjustment (Jet Speed Control) guaranteeing print quality.

Uptime – Unique head cleaning system to ensure trouble-free startup. Easy change of the consumables without stopping marking operations.



markem·imaje

the team to trust ■ ■ ■

Print features ■ ■ ■

- Mono-jet printhead
- G head (printing resolution: 71 dpi)
- Up to 4 lines of print
- Print speed: up to 4.4 m/s
- Font height: from 5 to 24 dots
- Character height: from 1.8 to 8.7 mm
- One and two-dimensional barcodes (Datamatrix)
- Wide choice of character sets (Latin, Arabic, Cyrillic, Greek, Japanese, Chinese, Hebrew, Korean...)

Operations ■ ■ ■

- Message library (up to 100 messages)
- International operator/machine interface (choice of 31 languages)
- Large, WYSIWYG, backlit, blue screen
- Integrated help for navigation and diagnostics
- Creation of logos directly on the operator/machine interface
- PCMCIA and Compact Flash cards reader
- IC60 ink circuit
- Jet Speed Control guarantees marking quality
- Automatic selection of fonts, depending on print speed and printhead/object distance
- Possibility to choose ink types: quick-drying and alcohol-base
- 2 sealed cartridges, 0.8 liter each
- Quick connect/disconnect of accessories (photocell, encoder, alarm)

Options ■ ■ ■

- RS-232/422 connectivity
- Printhead pressurization kit

Other characteristics ■ ■ ■

- Weight: 19.5 kg
- 3-meter flexible umbilical cable
- Stainless steel cabinet
- Dust/humidity protection rating: IP54
- No plant air required
- Operating temperature range: 0° to 40° C, depending on ink used
- Humidity: 10% to 90% non-condensing
- Electrical power supply: 100-120 V or 200-240 V with automatic switching; frequency 50/60 Hz; power 60 VA

Accessories ■ ■ ■

- Printer stand (stainless steel or aluminum)
- Printhead stand (stainless steel)
- Different printhead brackets
- Stainless steel printhead cover
- Photocell
- Encoder
- Alarm beacon (24 V)

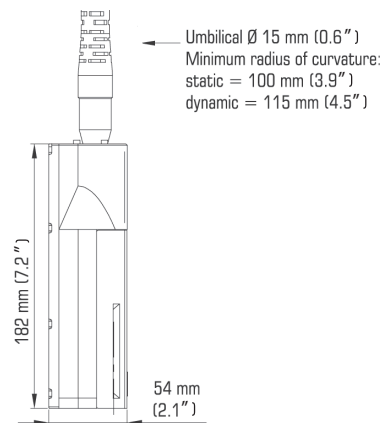
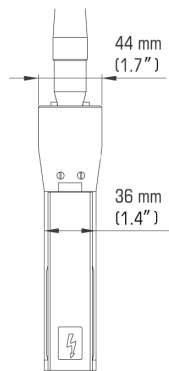
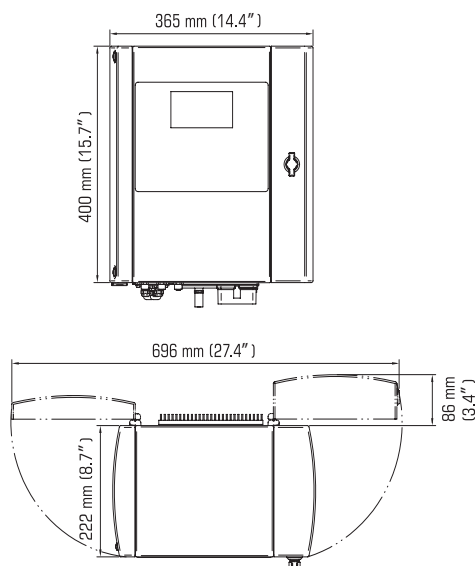

To learn more visit, www.markem-imaje.com



We reserve the right to amend the design and/or specifications of our products without notice.

9, rue Gaspard Monge
B.P. 110
26501 Bourg-lès-Valence Cedex - France
Tel.: +33 (0) 4 75 75 55 00
Fax: +33 (0) 4 75 82 98 10

150 Congress Street
Keene, NH 03431
United States of America
Tel.: +1 800-258-5356
Fax: +1 603-357-1835

markem·imaje

A  Company