

SHARP

MX-1800N

Digital Full Colour Multifunctional System



FULL-COLOUR **PERFORMANCE**
AND **PRODUCTIVITY** IN AN
AFFORDABLE, SPACE-SAVING DESIGN.



SHARP **DOCUMENT SOLUTIONS**



A PERFECT FIT FOR SMALL OFFICES WITH BIG IDEAS

Compact in size and affordable in price, the Sharp MX-1800N is a great choice for small, busy offices and anyone who is trading up to colour for the first time. Not only does it print high quality, 18-ppm colour and black and white, but it's great for all your copying, faxing and scanning needs, too. What's more, it has a whole range of powerful document management, filing and security features and options normally found only in larger machines.

EASY TO USE AND ENVIRONMENTALLY FRIENDLY

Built for efficiency, the MX-1800N has a user-friendly design that makes it easy for everyone in the office to use. A large, easy-to-read touch-screen LCD control panel with customisable keys helps users navigate quickly through advanced functions. What's more, Sharp OSA (Open Systems Architecture) allows third-party software developers to customise the MX-1800N for specific user applications.

The MX-1800N also brings today's businesses the superb environmental performance of Sharp, with newly developed supplies such as a low-consumption toner in a smaller cartridge that uses less packaging materials. Furthermore, the MX-1800N complies with both the RoHS* Directive, which restricts the use of hazardous substances, and the Energy Star programme, the international standard for energy-efficient products.



* RoHS: Restriction of the use of certain Hazardous Substances



Control panel

KEY FEATURES

Productive Output

- Speedy output of max. 18 ppm in both colour and black & white
- Quick first copy out time in both colour and black & white
- Network tandem function doubles output speed by linking two machines
- Standard hard disk and electronic sorting for both colour and black & white
- Large paper capacity of max. 2,100 sheets
- Standard 100-sheet Reversing Single Pass Feeder and stackless duplex module

Breathtaking Image Quality

- High-quality imaging with new toner
- Oil-less toner for brilliant colour output
- Enhanced Sharp Auto Colour Mode and Auto Colour Selection for easy colour copying



All-in-One Full-Colour MFP

- Standard PCL5c/PCL6 and optional PS3 emulation
- Full-colour network scanning with scan to e-mail/FTP server/desktop/network folder (SMB)/USB memory
- Sharpdesk™ for easy, integrated document management on a PC
- Document filing function to instantly reuse saved jobs
- Optional Super G3 fax and Internet fax (in black & white)
- LDAP support for easy browsing of e-mail addresses and fax numbers

Sharp's One-of-a-Kind Features

- Variety of advanced copy/print functions
- Large touch-screen LCD control panel and customisable user settings
- USB memory direct printing*1, external USB keyboard for easy typing
- Colour stamp function, mixed size original copy mode, easy text entry
- Sharp OSA™ (Open Systems Architecture)*2 allows third-party software developers to customise the machine to meet exact user needs

*1: Due to a wide variety of USB memory devices, compatibility cannot be guaranteed for all

*2: Requires optional MX-AMX2 and/or MX-AMX3

Industry-Leading Security Solutions

- Optional Data Security Kit encrypts and erases confidential data
- Secure Sockets Layer (SSL) and encrypted PDF for secure network communications
- Document Control function* prevents unauthorised copying, scanning, faxing and filing

* Requires optional Data Security Kit. May not work for certain types of documents and paper

Environment and User-Friendly

- Newly developed, environmentally conscious supplies
- Industry-leading energy-saving design (less than 1W in night-time standby for fax reception)
- Lead- and chromium-free design (RoHS compliant)
- Compact toner cartridge and less packaging materials
- Job Status screen lets you view the list of jobs in progress



HIGH PERFORMANCE OFFICE COLOUR PRINTING

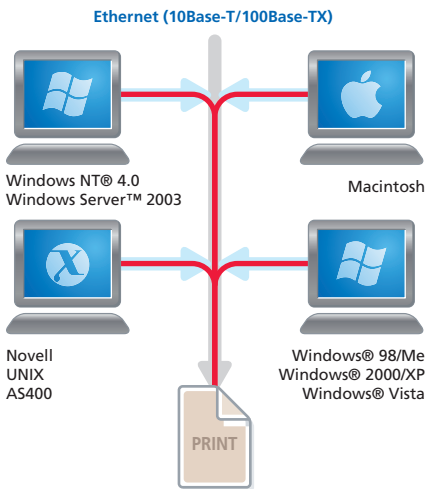

The MX-1800N is equipped with a variety of powerful performance features, including a single-pass printing function that delivers identical speeds, 18 ppm respectively - for both colour and black & white documents. The built-in processor handles office document and graphics files with superior efficiency, while the RIP Once/Print Many feature makes quick and effortless work of multi-page jobs.

at a glance...

- **Efficient colour and black & white printing** at 18 ppm
- **Stackless duplex module** saves you filing space and money
- **Network printing** supports the most commonly used network operating systems and protocols
- **USB memory direct printing***1 - conveniently print data directly from USB memory devices, without accessing a PC
- **PDF/TIFF/JPEG direct print***2 - save valuable time by printing PDF, TIFF or JPEG files without using the printer driver, either by calling and printing the file directly from an FTP server, direct printing from a Web page, or direct printing of e-mail attachments
- **Supports PCL6 and PCL5c** printer language emulations with Sharp Common Graphic User Interface for simplified use
- **Network tandem function** - double the output speed by using two MX-1800N's on the same network
- **Proof printing** - check a trial set before printing out a multi-page document in large numbers
- **PostScript 3** is available*3 for compatibility with more fonts and better graphics handling

*1: Due to a wide variety of memory devices, compatibility cannot be guaranteed for all

*2: Requires optional MX-PKX1; may not support all PDF, TIFF, JPEG file formats.

*3: Requires optional MX-PKX1

A Variety of Job Finishing Options

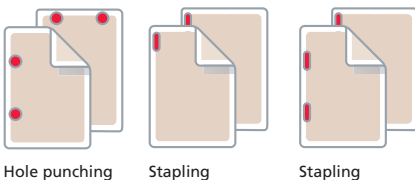

Space-saving inner finisher

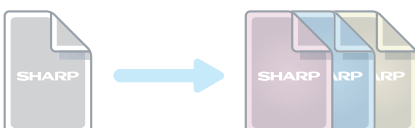

Carbon copy print

Finishing Options

An optional space-saving finisher is available for simple office jobs that require sorting, stapling and hole-punching.

Special Applications

- **Carbon copy print** - print multiple copies of the same data on plain and/or coloured paper fed from different paper trays
- **Form overlay** - store document formatting such as letterheads in colour, eliminating the need for pre-printed paper
- **Tab print** - print directly onto tabs on document separators and insert them into assigned positions

FAST, HIGH QUALITY COPYING

Designed to liberate your busy office, the MX-1800N boosts productivity with a fast 18 cpm copy speed respectively for both colour and black & white documents. And, advanced copy modes not only save you time and effort, they also ensure exceptional copy quality automatically - even for mixed colour and black & white documents, pages with halftone or colour backgrounds, originals with mixed paper sizes and more.

Auto Colour Selection in Copying



Original with colour and black & white pages

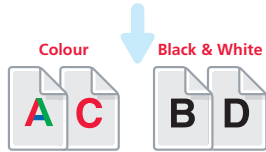

Distinguishes colour and black & white pages

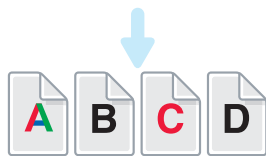

Outputs colour pages in Colour Mode and black & white pages in Black & White Mode

at a glance...

- **Fast colour and black & white** copying at 18 cpm
- **Quick first copy out time** - 8.9 sec. in colour, 6.3 sec. in black & white
- **Convenient 100-sheet RSPF** (Reversing Single Pass Feeder) makes any scan job easy; even double-sided documents are handled automatically
- **Mixed size original copy mode** automatically distinguishes documents of mixed sizes*¹ fed through the RSPF and chooses the appropriate paper
- **Enhanced Auto Colour Mode** clearly reproduces text even with colour or halftone dots in the background
- **Auto Colour Selection** - the MX-1800N will automatically detect colour and black & white documents from multi-page originals by selecting the appropriate mode for each page and then output the copy to match the original - this gives you greater cost savings
- **Scan Once/Print Many, electronic sorting and offset stacking** for highly productive copying
- **Large paper supply** of up to 2,100 sheets
- **Job Build function** - large-volume jobs can be scanned in batches and stored for output as a single job*²
- **Image editing functions** - multi-shot (4-in-1/2-in-1), multi-page enlargement, image repeat, mirror image and more

*1: Some restrictions apply when combining paper sizes of different format series.

*2: The number of pages that can be stored for the Job Build function depends on the machine's HDD capacity and other conditions.

High-Quality Imaging with New Toner

The MX-1800N adopts a newly developed toner that not only clearly reproduces thin lines, small characters and even halftone colours; the oil-less toner also produces vivid, natural-looking colour printouts that you can easily write messages or post sticky notes on.



Colour Stamp

Special Applications

- **Proof copy function** - check a trial set and make any necessary copy adjustments before outputting the entire volume
- **Colour stamp function** - stamps page numbers, the date or text such as "CONFIDENTIAL" in up to four different colours
- **Network tandem function** - double the output speed by using two MX-1800N's on the same network



EFFORTLESS COLOUR NETWORK **SCANNING**

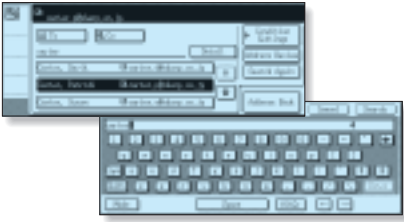

Improve workflow and make document distribution hassle-free by converting full-colour paper-based documents up to A3 in size into editable digital files. With the 100-sheet RSPF, the MX-1800N easily handles batch scans of mixed colour and black & white documents, as well as mixed size documents. You can send scanned files directly to a PC, an FTP server or even USB memory. What's more, LDAP (Lightweight Directory Access Protocol) support makes sending documents via e-mail even easier.

at a glance...

- **Full-colour scanning** to your PC desktop, e-mail, FTP server, network folder (SMB) or USB memory
- **Mixed size original scanning** automatically distinguishes documents of mixed sizes* fed through the RSPF and chooses the appropriate size
- **Auto Colour Selection** - if a multi-page original contains both colour and black & white pages, the MX-1800N selects colour or black & white modes accordingly
- **Enhanced Auto Colour Mode** clearly reproduces text even with colour or halftone dots in the background
- Compatible with **TWAIN-compliant** applications (pull scan)
- **Useful utility software** - Sharpdesk™ document management software
- **Lightweight Directory Access Protocol (LDAP)** allows easy browsing and storing of e-mail addresses for rapid distribution of scanned documents, as well as automatic synchronisation with your primary e-mail server
- **Various scanned file formats** - TIFF, PDF, encrypted PDF, JPEG (colour only)
- **Fast and easy destination selection** - register up to 999 frequently used numbers and dial with one-touch operation
- **Easy text entry** - preset frequently used e-mail subject titles or messages for easy one-touch entry or directly enter text from the MX-1800N's LCD control panel

* Some restrictions apply when combining paper sizes of different format series.

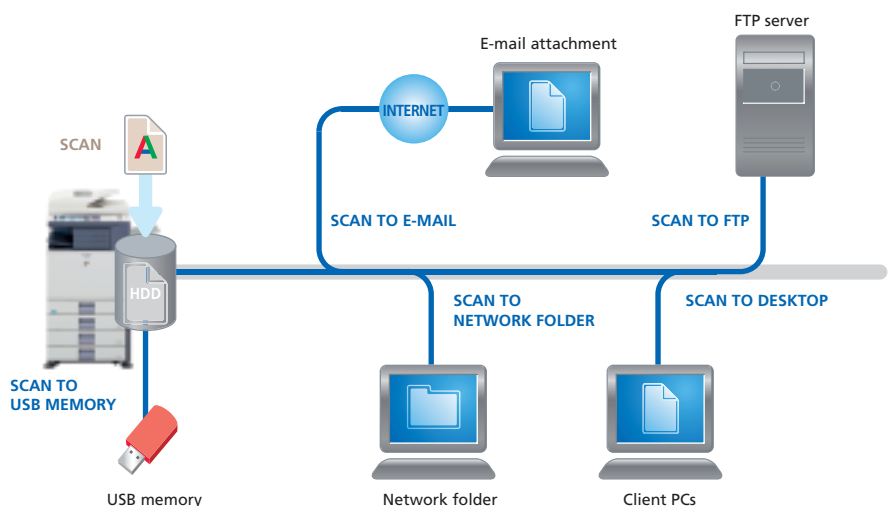

VERSATILE FAX WITH CHOICE OF TRANSMISSION

With the optional fax expansion kits, you can send faxes quickly and easily. Fax printed documents using the ultra-fast 33,600 bps Super G3 fax or save paper by faxing documents electronically using the PC-Fax/PC-Internet Fax function. The built-in duplex module can print incoming faxes onto both sides of the paper, further reducing costs. You can even set the machine to automatically copy and staple incoming faxes - a great time saver!

Note: Faxing is available only in black & white.

at a glance...

- **Extremely versatile** - send or receive single or double-sided faxes up to A3 in size
- **Saves time** - Super G3/JBIG compression for extra speed
 - on-line transmission reduces total operation time
 - 100-sheet RSPF enhances the efficiency of your fax jobs
- **Rapid transmission** - register up to 999 frequently used numbers and dial with one-touch operation
- **Paperless faxing with inbound routing** lets you check incoming faxes via e-mail and print only what you need
- **Dependable** - flash memory prevents data loss in a power failure
- **Duplex faxing** - scan and send both pages of two-sided documents and print incoming faxes onto both sides of paper
- **Internet fax** - send and receive faxes over the Internet with other ITU-T T-37 compliant machines without worrying about costs
- **PC-Fax/PC-Internet Fax** - send data directly from a PC to a fax machine without printing to paper



Automated Fax Finishing

The MX-1800N eliminates the need to copy and staple received faxes by hand. Simply use the Fax Output setting on the LCD control panel to designate the number of copies and the output tray.

Comparison between Super G3 and G3

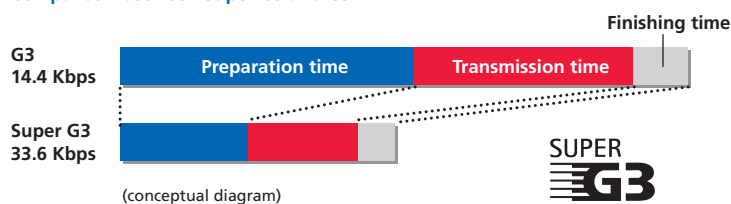



EFFICIENT WORKFLOWS WITH **FILING** FUNCTION

Simplify document management and protect your data with the Document Filing function. Store documents directly on the MX-1800N's built-in hard disk and eliminate the hassle of paper filing, making it even easier to retrieve documents the next time you need them.



Quick Filing with Temporary Storage

Save up to 1,400 pages or 1,000 files*¹ of processed copy, print, scan and fax*² job data in Quick File Folders on the hard disk for later use, eliminating the need to recreate jobs.

Advanced Filing for Long-Term Storage

Save up to 1,400 pages or 1,000 files*¹ of job data on the hard disk in up to 500 folders with customised names and locations and with enhanced security features to protect your sensitive data. Storage options include:

- Main Folder - stores files in a central location for convenient workgroup sharing
- Custom Folder - stores confidential files in private folders with password security

*¹: Measured using Sharp's standard chart (A4 with 6% coverage, black & white). The Quick File Folder shares the HDD with the Job Build function; up to 10GB of data storage is available when using both functions. The storage capacity will be less for colour pages.

*²: For fax and internet fax jobs, only transmitted data (not received faxes) can be saved in the Document Filing function

Easy Access

Conveniently access documents stored on the hard disk from the control panel display or through a Web browser.

Secure Storage

With the optional Data Security Kit installed, all data that goes through the MX-1800N's hard disk is encrypted, enabling you to protect confidential data and documents from unauthorised access.

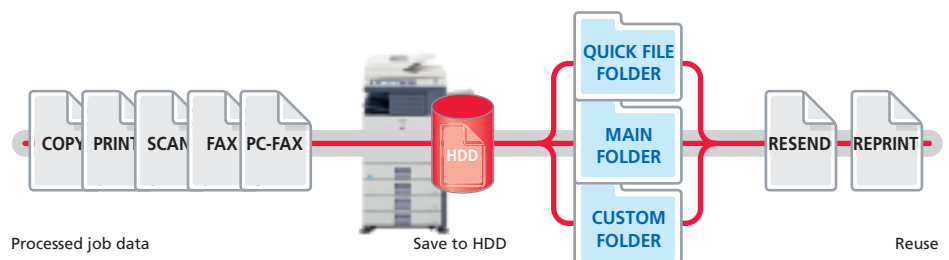

POWERFUL UTILITY SOFTWARE

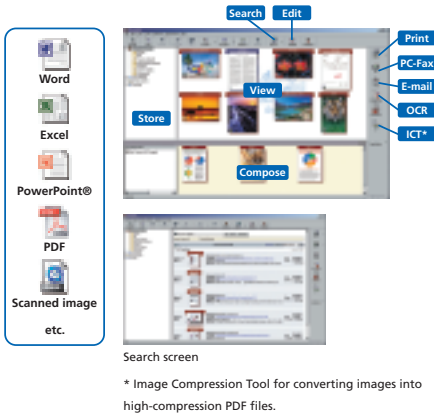

Easy Document Management with Sharpdesk™

Sharp's original document management software, Sharpdesk™, lets you manage documents in over 200 file formats in a single application right on your PC desktop, making it possible to integrate scanned paper-based documents and files created in popular applications such as Word. It allows you to organise, edit, search and distribute your documents, all with simple drag-and-drop operation. Features include:

- Intuitive desktop display features **thumbnail** viewing
- Sharpdesk Imaging provides **annotation** tools for paper-free proofreading
- Sharpdesk **Composer** combines different types of files into a single document
- **Optical character recognition** converts documents into editable text files
- **Output zone** distributes files to e-mail, printers and other applications
- **File search** allows searching by file name, keyword or thumbnail

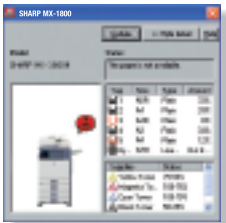

Printer Status Monitor

Printer Status Monitor

The Printer Status Monitor lets you remotely check the status of the MX-1800N — to see if it has sufficient paper and toner, for instance — through a simple, icon-based graphical interface on your PC desktop before starting the job and without leaving your desk. In addition, the Printer Status Monitor eliminates wasted trips to the machine by notifying you when your job has been completed and is ready for collection.

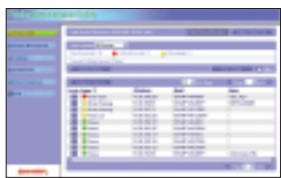

Web-based PAU 4.0

Web-Based Printer Administration Utility

Sharp's original Printer Administration Utility makes printer networks easier to manage by allowing network administrators to customise monitored items and view settings, such as the IP address, directly from their PC through a standard Web browser.

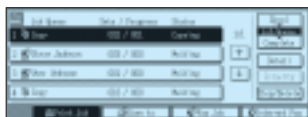

Job Status screen

Job Status Screen

Whether printing or copying, the control panel displays a list of all jobs, showing you at a glance the jobs in progress and the position of your job in the queue.



INDUSTRY-LEADING MULTI-LAYERED SECURITY

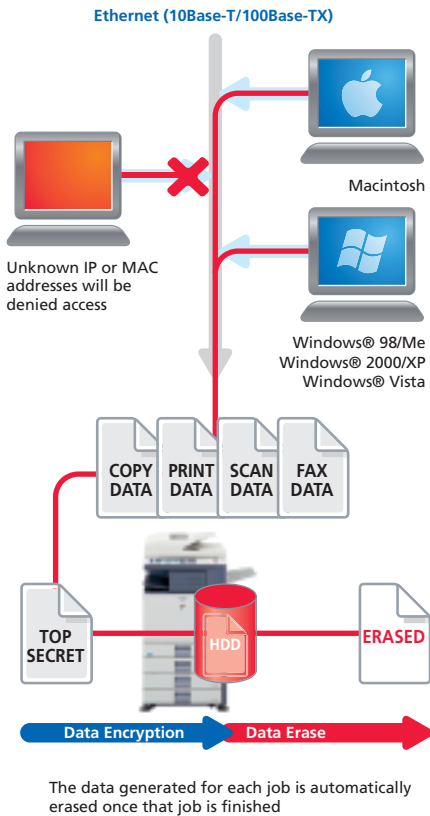

With multiple levels of network and data security to cover a wide range of security needs, Sharp's industry-leading security solutions bring today's businesses increased confidence and peace of mind. The MX-1800N safeguard's sensitive data with powerful, enhanced security functions that eliminate the worry of unauthorised use and guarantee greater protection for your confidential information.

at a glance...

- **Data Security Kit¹** encrypts and removes any data on the hard disk or internal memory safely and completely after use
- **Document Control function²** prevents unauthorised copying, scanning, faxing and filing
- **Encrypted PDF with password protection** prevents unauthorised viewing of confidential image data
- **Secure Network Card** provides network port and protocol management, as well as a firewall that prevents direct connection and access by unauthorised users
- **Confidential data storage and printing** protects sensitive information by requiring the user to enter a PIN code before the documents are produced
- **Secure Socket Layer (SSL)** encrypts data communications to prevent data leakage through the network
- **User authentication** requires logging into the machine with passwords for machine access
- **Secure data storage for Document Filing²** — all data that goes through the hard disk is encrypted, while passwords used in the Advanced Filing function ensure solid security

*1: Optional

*2: Requires optional Data Security Kit. May not work for certain types of documents and paper

Document Control Function (example: unauthorised copying)

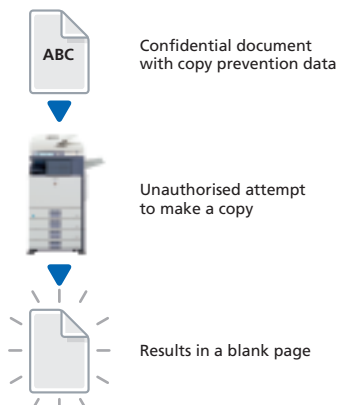

Document Control Function

Document Control¹ prevents unauthorised copying, scanning, faxing and filing of confidential documents. The MX-1800N embeds copy prevention data onto a document when it is first copied or printed. It will then detect this data if someone tries to make a copy of the document. Any unauthorised attempts to copy a Document Controlled-document will simply be cancelled². The MX-1800N will also generate an e-mail alert to notify the administrator.

*1: Requires optional Data Security Kit. May not work for certain types of documents and paper.

*2: May result in the output of a blank page if paper has already been fed for the job before the MX-1800N detects copy prevention data.

Data Security Kit

Digital copier/printers or multifunction products can retain hundreds of pages of confidential information from previous jobs on their hard disks or internal memory. To safeguard this information from unauthorised access, the optional **Data Security Kit** automatically encrypts or erases the data after each job is complete as well as data stored both on the hard disk and in the address book.

OPTIONS

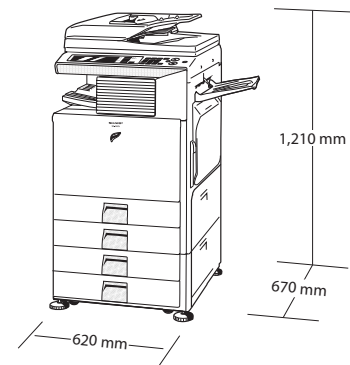

1. MX-FNX1
MX-PNX1A/C/D

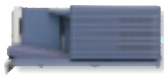

2. MX-TRX1



6. MX-FXX1



3. MX-DEX2



4. MX-DEX1



5. MX-DKX1



Finishing

- 1. MX-FNX1 Finisher**
A3 to B5 (offset/staple), A3W to A5R*¹ (non offset)
Offset tray (upper): max. 500-sheet paper capacity*²
Stapling capacity: max. 50-sheet multi-position staple*²
Staple position: 3 locations (front, rear or both)

Optional hole punch function for MX-FNX1:
MX-PNX1A 2-hole punch unit
MX-PNX1C 4-hole punch unit
MX-PNX1D 4-hole wide punch unit

- 2. MX-TRX1 Exit Tray Unit**
Exit tray for main machine

*1: Except A5
*2: A4 or smaller, 80 gsm

Base Unit

- 3. MX-DEX2 Stand with 2 x 500-Sheet Paper Drawers**
A3 to B5R, 500 sheets each (80 gsm) for lower and upper trays
- 4. MX-DEX1 Stand with 500-Sheet Paper Drawer**
A3 to B5R, 500 sheets (80 gsm)
- 5. MX-DKX1 Cabinet**

Connectivity Board

- 6. MX-FXX1 Fax Expansion Kit**
Super G3 fax module

MX-PKX1 PS3 Expansion Kit
Enables PostScript printing

MX-FWX1 Internet Fax Expansion Kit

Additional Sharpdesk™ licenses:
MX-USX1 x 1 user
MX-USX5 x 5 users
MX-US10 x 10 users
MX-US50 x 50 users
MX-US100 x 100 users

MX-FRX1U Data Security Kit (commercial version)
Enables data encryption and erasure

MX-AMX1 Application Integration Module
MX-AMX2 Application Communication Module
MX-AMX3 External Account Module
Enables machine customisation by third-party software developers

SPECIFICATIONS

MX-1800N Digital Full Colour Multifunctional System



General

Type	Desktop
Technology	Laser
Engine speed (max.) ^{*10}	A4, portrait A3
	Colour: 18 cpm/ppm 10 cpm/ppm Black & white: 18 cpm/ppm 11 cpm/ppm
Paper size	Max. A3 wide, min. A5R
Paper weight	60 - 105 gsm (bypass 55 - 209 gsm)
Paper capacity	Standard: 1,100 sheets (two 500-sheet trays and 100-sheet multi-bypass tray), Maximum: 2,100 sheets
Warm-up time	Less than 80 sec.
Memory	[Copier memory] Standard 768MB [Printer memory] Standard 640M, 40GB HDD ^{*1}
Power requirements	Rated local AC voltage $\pm 10\%$, 50/60 Hz
Power consumption (max.)	1.84 kW (200 to 240V)
Dimensions (W x D x H)	620 x 670 x 950 mm
Weight	Approx. 112 kg

Copier

Original paper size	Max. A3
First copy time ^{*2}	Full colour: 8.9 sec., black & white: 6.3 sec.
Continuous copy	Max. 999 copies
Resolution	600 x 600 dpi
Gradation	Equivalent to 256 levels (colour) Equivalent to 2 levels (black & white)
Zoom range	25 to 400% (25 to 200% using RSPF) in 1% increments
Preset copy ratios	10 ratios (5R/5E)
Features ^{*3}	Auto paper selection (mixed/random size feeding), auto magnification selection, paper type selection, auto tray switching, rotation copy, electronic sorting, network tandem copy, book copy, margin shift, dual page copy, card shot, edge/centre erase, multi-shot (4-in-1, 2-in-1), cover/transparency/tab page insertion, pamphlet copy, 2-sided copy orientation change, XY zoom, black & white reverse, mirror image, duplex copy, toner save mode, pre-heat/auto power shut-off modes, reserved copy, job programme, image repeat, irregular original/paper size input, stamps (date, character, page), multi-page enlargement, tab copy, centering, proof copy, job build, document control, user authentication (200 accounts), auto colour selection, enhanced Sharp auto colour mode, auto calibration

Network Scanner

Scan method	Push scan (via operation panel) Pull scan (with TWAIN-supporting application)
Resolution	Push scan: 100, 200, 300, 400, 600 dpi Pull scan: 75, 100, 150, 200, 300, 400, 600 dpi, 50 to 9600 dpi
File formats	TIFF, PDF, encrypted PDF, JPEG (colour only)
Scanner utilities	Sharpdesk™
Scan destinations	Scan to e-mail, desktop, FTP server, network folder (SMB), USB memory
Features	Internet fax ^{*4} , PC-Internet fax transmission ^{*4} , enhanced Sharp auto colour mode, mixed size original scanning, LDAP support, direct entry (address/subject/message), 999 one-touch dials, 500 group dials, 48 job programmes, broadcasting, long original scanning (max. 800 mm), card shot, edge/centre erase, job build, user authentication (200 accounts), auto colour selection

Document Filing

Document filing capacity	Main and custom folders: 10GB, 1400 pages ⁵ or 1000 files Quick file folder: 10GB, 1400 pages ⁵ or 1000 files
Stored jobs	Copy, print, scan, fax transmission ⁶
Storage folders	Quick file folder, main folder, custom folder (max. 500 folders)
Confidential storage	Password protection

Network Printer

Resolution	600 x 600 dpi 600 x 600 dpi (600 x 1200 dpi PS3 B/W only with optional MX-PKX1)
Interface	USB 2.0: High-speed mode for printing, Full-speed mode for other functions 10Base-T/100Base-TX
Supported OS ^{*7}	Windows NT [®] 4.0 SP5 or later, Windows [®] 98/ME, Windows [®] 2000, Windows [™] server 2003, Windows [®] XP, Windows [®] Vista, Mac OS 9.0 to 9.2.2, Mac OS X 10.1.5, 10.2.8, 10.3.3 to 10.3.9, 10.4
Network protocols ^{*7}	TCP/IP, IPX/SPX (NetWare), NetBEUI, EtherTalk (AppleTalk)
Printing protocols	LPR, Raw TCP (port 9100), POP3 (e-mail printing), HTTP, Novell Printserver application with NDS and Bindery, FTP for downloading print files, EtherTalk printing, IPP
PDL emulation	Standard: PCL 6/5c Option ^{*8} : PS3 emulation
Available fonts	80 fonts for PCL, 136 fonts for PS3 emulation ^{*8}
Features ^{*3} ^{**}	Network tandem print, RIP Once/Print Many, job retention (print hold, proof print, confidential print), direct PDF/TIFF/JPEG printing, carbon copy print, duplex print, printer administration utility & status monitor, user authentication (200 accounts), IP/MAC address filtering and port/protocol management, font and form download, pamphlet style, binding edge, N-up (2/4/6/8/9/16), paper/output tray selection, cover insertion, transparency interleave, fit to page, watermarks, offset output, form overlay, auto configuration, barcode font compatibility, tab print, poster print

Black & White Facsimile (optional MX-FXX1 required)

Compression method	MH/MR/MMR/JBIG
Communication protocol	Super G3/G3
Transmission time	Less than 3 seconds ^{*10}
Modem speed	33,600 bps to 2,400 bps with automatic fallback
Transmission resolution	Standard: 203.2 x 97.8 dpi Extra Fine: 406.4 x 391 dpi
Recording width	A3 to A5
Memory	8MB flash memory
Grey scale levels	Equivalent to 256 levels (halftone)
Features	Duplex transmission/reception, quick on-line transmission, error correction mode, F-Code compatibility (confidential, relay broadcast), LDAP support, 999 one-touch dials, 500 group dials, 48 job programmes, broadcasting number registration, polling, memory transmission/reception, auto reduction (transmission/reception), rotation transmission/reception, print actual size, 2-in-1, long original transmission (max. 800 mm), PC-Fax transmission, timer transmission, paperless faxing with inbound routing to e-mail, activity report, anti-junk fax, dual page scan, mixed size original scanning, job build, user authentication (200 accounts)

Options

Please refer to the Options section on the previous page.

^{*1}: 1GB = One billion bytes when referring to hard drive capacity. Actual formatted capacity is less. ^{*2}: When using document glass and feeding A4 sheets from 1st paper tray, without Auto Colour Selection and Auto Colour mode, polygon in rotation. ^{*3}: Some features require option(s). ^{*4}: Optional MX-FWX1 required. ^{*5}: Measured using Sharp's standard chart (A4 with 6% coverage, black & white). The Quick File Folder shares the HDD with the Job Build function; up to 10GB of data storage is available when using both functions. The storage capacity will be less for colour pages. ^{*6}: Optional MX-FXX1 required. ^{*7}: Optional MX-PKX1 required for Mac OS and EtherTalk. ^{*8}: Optional MX-PKX1 required. ^{*9}: Some features are not available according to the printer driver used. ^{*10}: Based on Sharp's standard chart with approx. 700 characters (A4 portrait) at standard resolution in Super G3 mode, 33,600 bps, JBIG compression. ^{*10}: Copy mode: When copying same document continuously on portrait A4 plain paper in non-offset mode. Print mode: When printing same document continuously on portrait A4 plain paper in non-offset mode, excluding processing time.

SHARP



Design and specifications are subject to change without prior notice. All information was correct at time of print. The ENERGY STAR logo is a certification mark and may only be used to certify specific products that have been determined to meet the ENERGY STAR programme requirements. ENERGY STAR is a US registered mark. The ENERGY STAR guidelines apply to products only in the US, Europe, Australia, New Zealand and Japan. Windows and Windows NT are registered trademarks of Microsoft Corporation. All other company names, product names and logos are trademarks or registered trademarks of their respective owners. ©Sharp Corporation 2006 Ref: ESBC-MX-1800N. All trademarks acknowledged. E&OE.