

VITA VACUMAT® 4000 PREMIUM T

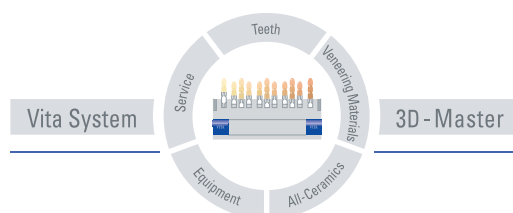

Operating manual
Date of issue: 07-07



VITA

Table of contents

1 FOREWORD	6
1.1 PICTOGRAMS.....	6
1.2 COPYRIGHT	6
2 TECHNICAL INFORMATION	7
2.1 GENERAL DESCRIPTION	7
2.2 EXTERNAL CONTROL EQUIPPED WITH.....	7
2.3 FIRING PROGRAMS.....	8
3 SERVICE PROGRAMS	8
4 SAVING OF FIRING DATA FOR QUALITY ASSURANCE	9
5 SAFETY FUNCTIONS	9
6 DIMENSIONS/WEIGHTS	10
6.1 FIRING UNIT	10
6.2 CONTROL UNIT	10
6.3 ELECTRIC DATA FIRING UNIT/CONTROL UNIT	10
6.4 ELECTRIC DATA VACUUM PUMP	10
6.5 SCOPE OF DELIVERY.....	10
7 INSTALLATION AND START-UP	11
7.1 MOUNTING LOCATION.....	11
7.2 CONNECTING THE UNIT TO THE MAINS SUPPLY.....	12
7.3 SHUTTING DOWN THE UNIT, OUT OF OPERATION.....	13
8 NOTES ON SAFETY	13
8.1 INTENDED USE	13
8.2 NOTES ON INFORMATION DECALS.....	14
8.3 CLEANING THE FIRING UNIT.....	15
8.4 OPERATION AND CLEANING OF THE CONTROL UNIT.....	15
8.5 FUSES.....	15
8.6 CE – SIGN	15
8.7 FAN.....	16
8.8 VOLTAGE SUPPLY FAILURE.....	16
8.9 WARRANTY AND LIABILITY	16
8.10 SPARE PARTS.....	16
9 TEMPERATURE RISE	17
10 AUTOMATIC TEMPERATURE ADJUSTMENT	17
11 USER ASSIGNED PROGRAMS	18
11.1 CHANGING THE USER/CREATING A USER	18
12 GENERAL OPERATION OF UNIT	19
12.1 NUMERICAL INPUT	19
12.2 ALPHANUMERICAL/NUMERICAL INPUT	20

12.3	QUICKSTARTING A FIRING PROGRAM – QUICKSTART	20
13	START MENU	21
14	STANDBY	22
14.1	ADJUSTMENT OF STANDBY TEMPERATURE	22
14.2	START/STOP STANDBY MODE	23
15	SELECTING A FIRING PROGRAM.....	24
16	CHANGING PROGRAM VALUES.....	26
16.1	CHANGING PROGRAM VALUES IN GRAPHICS MODE	26
16.2	CHANGING PROGRAM VALUES IN TABULAR MODE	28
17	LIFT POSITIONS AND POSITION TIMES FOR PRE-DRYING.....	30
17.1	DIRECT INPUT OF CHANGES FOR LIFT POSITION AND POSITION TIME.....	31
17.2	INPUT OF CHANGES TO LIFT POSITION AND POSITION TIME IN THE PRE-DRYING MENU ..	33
18	LIFT POSITIONS FOR COOLING	34
18.1	DIRECT INPUT OF CHANGES TO THE LIFT POSITION COOLING	34
18.2	ENTERING CHANGES TO THE LIFT POSITION IN THE COOL DOWN MENU	35
19	VACUUM SETTINGS.....	37
20	PRE-VACUUM ADJUSTMENT.....	39
21	CREATING PROGRAM GROUPS.....	39
21.1	DELETING PROGRAM GROUPS.....	41
21.2	CHANGING A PROGRAM GROUP.....	42
21.3	COPYING/INSERTING A PROGRAM GROUP.....	44
21.4	SORTING PROGRAM GROUPS.....	45
22	CREATING NEW FIRING PROGRAMS	47
22.1	DELETING FIRING PROGRAMS.....	49
22.2	CHANGING FIRING PROGRAMS.....	51
22.3	COPYING/INSERTING FIRING PROGRAMS.....	53
23	SERVICE PROGRAMS.....	56
23.1	INFORMATION ABOUT THE UNIT/SOFTWARE.....	56
23.2	LANGUAGE SELECTION.....	56
23.3	EXPORT FAILURE REPORT	57
23.4	SCREEN SETTINGS	57
23.5	PROCESS DATA.....	57
23.6	LOADING FIRING PROGRAMS FROM THE MEMORY STICK	57
23.7	DATE/TIME.....	58
23.8	DISPLAY FORMATS	58
23.9	LIFT SPEED SETTINGS	59
23.10	OPERATING DATA	59
23.11	TEMPERATURE CALIBRATION BY MEANS OF SILVER TEST.....	60
23.12	VACUUM CALIBRATION	60
23.13	PROGRAMS CANCEL	61
23.14	MELODY FOR END OF PROGRAM	61

23.15 DRY – PROGRAM (VITA IN-CERAM SPRINT)	61
24 SOFTWARE UPDATE	62
25 FACTORY SETTINGS	62
26 FIRING TABELS	63
26.1 VITA VM 7	63
26.2 VITA VM 9	63
26.3 VITAVM®9 FOR VITABLOCS®	64
26.4 VITA VM 13	64
26.5 VITA VM®15	65
26.6 VITA VMK 95	65
26.7 VITA OMEGA 900	66
26.8 VITA TITANIUM PORCELAIN	66
26.9 VITADUR® ALPHA.....	67
26.10 SOLDERING IN VITA VACUMAT® 4000 PREMIUM T.....	67
27 ERROR MESSAGES	68

1 Foreword

These operating instructions provide a considerable help for successful and risk free operation of the unit.

The operating instructions contain important information for safe, proper and economical operation of the equipment. Compliance with these instructions helps to avoid dangers, to reduce repair costs and downtimes and to enhance the reliability and the service life of the unit.

The illustrations and drawings in these operating instructions serve the general clarification and are by no means substantial the details of the equipment design.

The operating instructions must be available near the unit at any time. They must be read and applied by all persons involved in work on/with the unit, such as.:

- operation,
- troubleshooting and fault rectification during operation,
- care,
- upkeep (maintenance, inspections, repair).

1.1 Pictograms



This pictogram warns of dangerous voltage. Before opening the unit it must be isolated from the power supply by pulling out the mains plug.



This pictogram warns of hot surfaces. Injuries by burning are possible.



Please note that electrical/electronic units must be disposed of separately. Do not dispose with household waste. The black bar below the "garbage bin" symbol indicates that the unit was put into circulation after August 13, 2005. Please note that the unit is subject to regulation 2002/96/EC (WEEE) and applicable national laws and must be disposed of accordingly. Please contact your dealer if the unit needs to be disposed of.



This pictogram draws the attention to dangerous situation with the possible risk of personal injury or damage to the equipment.



This pictogram highlights useful hints, explanations and additional information concerning handling of the unit.

1.2 Copyright

These operating instructions must be treated confidentially. They should only be used by authorized persons. Disclosure to third parties is only permitted with the written approval of VITA Zahnfabrik H. Rauter GmbH&Co.KG.

All documents are protected by copyright law.

Any disclosure as well as the reproduction of documents, even in form of excerpts, utilization and publication of its content is not permitted, if not explicitly approved. Violations are liable to prosecution and oblige to compensation.

All rights concerning the exercise of industrial property rights remain reserved.

2 Technical information

2.1 General description

- Powerful in technology – highest level of temperature accuracy due to temperature control via 2 temperature sensors – time saving operating comfort – modest spatial requirements - optimal firing results
- Housing made of paint finished sheet steel and stainless steel
- Firing charge racks
- Firing chamber fitted with high quality insulating material
- Quart material firing muffle
- Temperature sensor (platinum / rhodium - platinum)
- Automatic temperature adjustment
- Temperature accuracy plus/minus 2 °C

2.2 External control equipped with

- Clearly laid out colour graphics touch screen display
- Clearly arranged and self-explaining operation
- Operation related notes for possible inputs
- Screen for graphics and tabular mode
- Internal memory for approx. 500 firing programs
- USB – Memory Stick for user specific programs
- Software updates via Memory Stick
- Recording of firing data via Memory Stick
- RS 232 scanner port

2.3 Firing programs

- Memory capacity for approx. 500 firing programs.
- Adjustment of standby temperature.
- Arrangement of firing programs acc. to material groups.
- Possibility of numerical/alpha-numerical input of firing groups/firing programs.
- Creation, deletion, changing, copying/inserting, sorting of material groups.
- Creation, deletion, changing, copying/inserting, sorting of firing programs.
- Temperature rise adjustable in °C/minute (°F/minute) or in minutes.
- Temperature rise with simultaneous activation of the vacuum pump.
- Temperature rise only after the vacuum value is reached/maintained.
- Changing of program values for non-recurrent program execution.
- Adjustable pre-vacuum
- Adjustable vacuum time.
- Adjustable vacuum value.
- Opening of the firing chamber while maintaining the standby temperature.
- Standby mode after program end.
- User program memory by means of Memory Stick.
- User program selection by means of Memory Stick.
- Quick cooling down to standby temperature after program end.

3 Service programs

- Language selection (D, E, F, SP, I)
- Information (software, software update, equipment-no., Service e-mail)
- Display brightness control
- Saving – exporting process data
- Setting Date / Time
- Format – display of temperature °C or °F, date / time 24h/am/pm.
- Adjustment of lift speed.
- Operating data (total operating hours, operating hours of firing muffle, information concerning the firing muffle, number of firing programs started)
- Calibration (program for silver test, input for temperature offset, vacuum adjustment)
- Termination of program (press "Stop" button 1 or 2 times)

4 Saving of firing data for quality assurance

- Saving of nominal and actual firing data values (see section **23.5**).
- Saving of user name, equipment-no., date of firing incident, job-no.,
- Saving of material information via scanner* (manufacturer, article-no., batch-no.)
- These data are saved to the memory of the control unit and exported to the management program* (FDS – Firing – Data – System) on the PC by means of a Memory Stick (see section **23.5**).



*Management program and scanner are special accessories and must be ordered separately.

5 Safety functions

- Temperature sensor monitoring
- Temperature monitoring
- Vacuum monitoring
- Voltage failure protection
- Lift monitoring

6 Dimensions/weights

6.1 Firing unit

- Width: 240 mm
- Depth: 340 mm
- Height: 460 mm
- Housing: Steel/stainless steel
- Weight: 14,0 kg
- Firing chamber capacity: Diameter: 90 mm
Height: 55 mm
- Firing chamber temperature: max. 1200°C

6.2 Control unit

- Width: 210 mm
- Depth: 160 mm
- Height: 160 mm
- Housing: Steel/stainless steel
- Weight: 2,0 kg

6.3 Electric data firing unit/control unit

- Electric connection: 230 Volt AC, 50 Hz
or 100/110 Volt AC, 50/60Hz
- Wattage: max. 1500 Watt

6.4 Electric data vacuum pump

- Electric connection: 230 Volt, 50/60 Hz
or 100/110 Volt, 50/60 Hz
- Wattage: max. 0.2 kW
- Weight: approx. 6.4 kg

6.5 Scope of delivery

Unit in special cardboard box, complete with:

- 1 control unit
- 1 Memory Stick
- 1 Connecting cable for control unit
- 1 Firing socket
- 1 Connecting cable for mains supply
- 1 Core pincers
- 1 Package with firing carriers A + B
- 1 Package with firing supports G
- 1 Operating instructions
- 1 Stylus for control unit

Special accessories on request:

- Vacuum pump: 230 Volt, 50/60HZ or 100/110 Volt, 50/60 Hz
- Management program FDS
- Scanner

7 Installation and start-up

7.1 Mounting location

- Install the unit in a dry, heated room with a clearance of at least 25 cm to the nearest wall.
- With temperatures below 15 °C (e.g. after transport) let the unit rest for about 30 minutes at room temperature before starting it up.
- Make sure the unit is standing on a temperature resistant surface. The radiation and heat development is within a harmless range. However, it cannot be completely ruled out that sensitive furniture surfaces and veneers will show slight discoloration caused by the permanent exposure to heat over the course of time.
- Avoid exposure to direct sunlight.
- Do not place any inflammable objects near the unit.
- Do not place the control unit into the direct heat emission range of the firing chamber.



Abb. 1

- 1 Rack for firing objects
- 2 Main switch
- 3 Vacuum connection
- 4 Connection, vacuum pump
- 5 Mains connection
- 6 Fuses

7.2 Connecting the unit to the mains supply

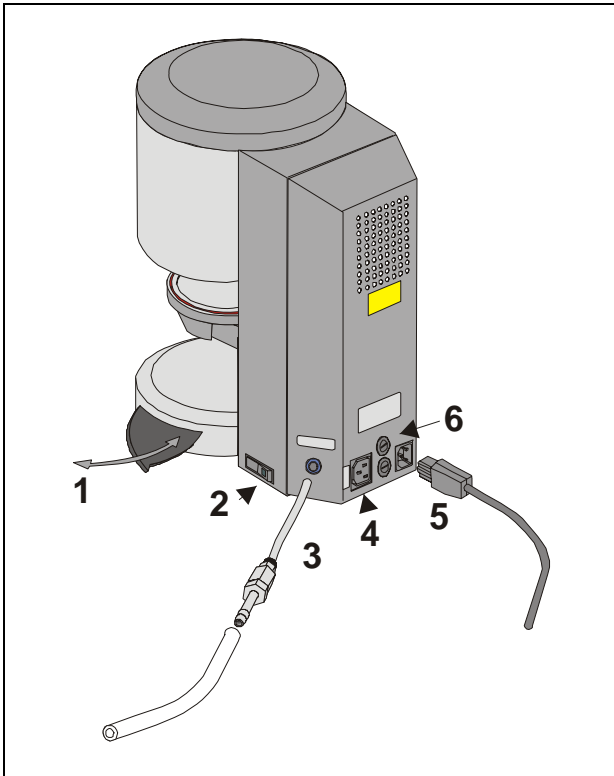

Before start-up, observe item 4 "Notes on safety"!



Abb. 2

- 1 Control unit
- 2 Firing socket

- Plug the connecting cable into control unit (2/1) and firing unit.
- Connect the vacuum pump (**Abb. 1**)
- Use the supplied mains lead to connect the unit to the mains supply (**Abb. 1**). The connecting cable should be a hot equipment supply lead of type HO5RR-F 3G1,0 mm². Avoid connecting to a multiple socket outlet with extension lead, because there is a risk of fire when overloaded.
- Switch on the unit by the main switch, the lift moves to bottom position.
- Clean lift plate and lift plate seal (dust particles resulting from the transport of the unit).
- Place the firing socket (2/2) on the lift plate.
- Press button **Start** to activate standby mode (see standby mode).

During initial start-up of the unit enter "Date/Time".

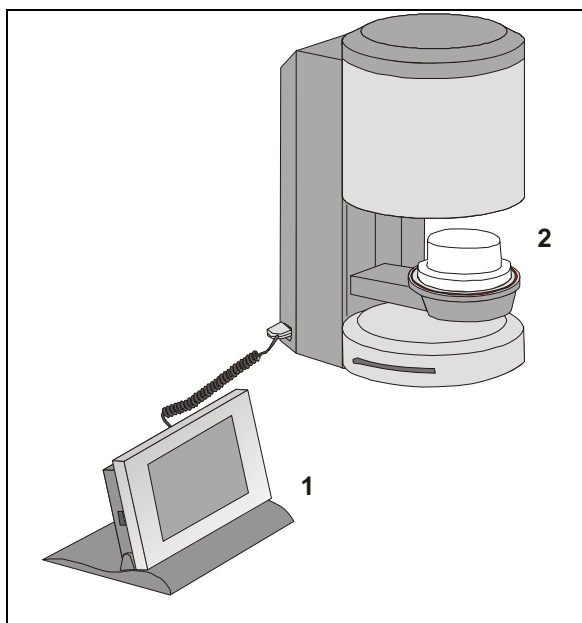
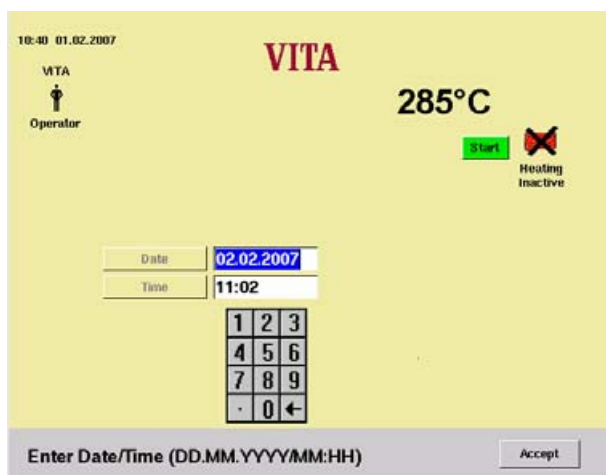

- Input Date: DD.MM.YY.
- Input Time: HH:MM
- Press button "Accept" – the display shows the main menu.

see also section 23.7

7.3 Shutting down the unit, out of operation

If the unit is not used the lift should be retracted into the firing chamber and the unit switched off by the main switch (see Fig. 1, item 2). Closing the firing chamber protects the insulation and prevents the absorption of moisture. To shut down the unit press the button with the switch-off symbol, see section 13, the lift is automatically retracted, the display indicates, switch off the unit by the main switch.

After selection of a firing program there is also the possibility to activate the automatic shutdown, see section 15 – night program.

After expiry of the firing program and cooling down of the firing chamber to 200 °C the lift is automatically retracted and the unit switched to standby mode, display and heating are switched off.

8 Notes on safety



For your own personal safety you should thoroughly read the following notes on safety before starting operation of the unit.

8.1 Intended use

Basis for the design of the unit

The unit is of state of the art design and complies with the generally accepted rules concerning health and safety.

However, danger for the health and safety of the user or third parties as well as impairments of the unit and other material values may arise if the unit is improperly used.

Inadmissible modes of operation

Operation of the unit is not permitted

- with power sources, products etc. which are subject of a dangerous chemicals ordinance or which could affect the health of the operating personnel in any other way
- with equipment that has been changed by the user

Permitted modes of operation

Operation of this machine is only permitted if these operating instructions were read and understood and the procedures described are complied with.

Any other use and any use beyond these limits, such as the processing of products other than the ones specified and the handling of hazardous or health threatening substances, is considered as unintended use.

The manufacturer/supplier will not assume liability for damage resulting from this. The risk must solely be born by the user.

8.2 Notes on information decals



Abb. 3



After removing the back plate and with the unit switched off parts of the mains unit on the printed circuit board may still carry a remanent voltage of up to 400 Volt.

The manufacturer will not assume liability for accidents of the user caused by work on the opened unit.

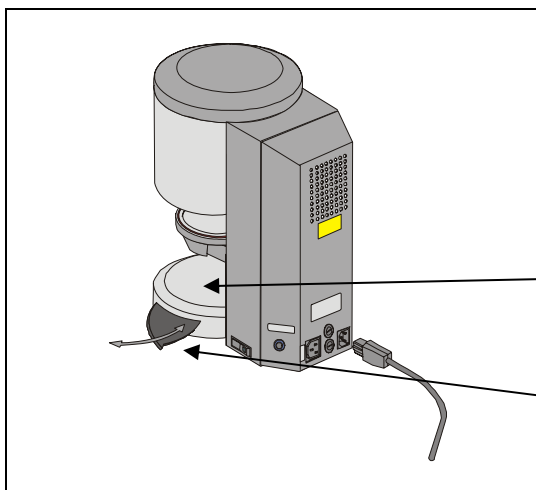

Do not place any objects near the lifting plate (**Abb.3**). The lift will move down to bottom position when switching on the unit.

Use the laterally extendable racks to deposit firing objects (**Abb. 3**).

Never operate the units without the firing socket attached (**Abb. 2**).

In continuous operation (max. end temperature, max. firing time) parts of the firing chamber may reach increased temperatures (higher than 70 °C).

Do not reach with your hands into the open firing chamber when the unit is connected, there is a risk of touching electrically live or hot parts.

8.3 Cleaning the firing unit

Pull out the mains plug before starting to clean!

Cleaning of the firing chamber from inside is not necessary, regular cleaning of the housing with a damp cloth enhances the operational reliability.

Do not use any cleansing agents or combustible fluids for cleaning .

8.4 Operation and cleaning of the control unit.

The control unit is **solely** to be operated with the pin supplied for this purpose.

The use of other operating elements will cause damage to the touchscreen.

Clean the display at regular intervals with a screen cleansing agent.

Such cleansers do not leave any scratches, generate an anti-static effect and retard resoiling.

Damage to the display caused by inappropriate handling during operation or cleaning, are excluded from warranty.

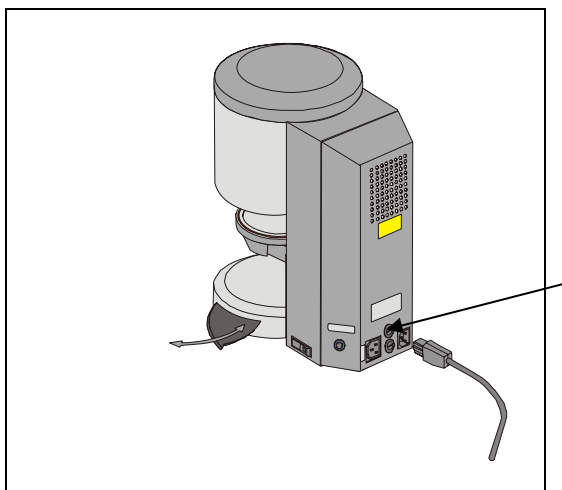

8.5 Fuses

2 fuses for the unit are installed on the rear side of the unit. The information decals provide information on the fuses used in the unit. Fuses with different capacity must not be used.

230 Volt version

T 8 H 250 V

100/110 Volt version

T 15 H 250 V



8.6 CE – Sign

The CE - mark entails a legally binding statement that the unit complies with the basic requirements, directive 73 / 23 / EEC, amended by directive 93/68/EEC, concerning electrical equipment.

We declare the conformity based on the following standards:

- Safety: IEC 610110-1:2001 2nd edition and IEC 610110-2-010:2003 2nd edition.

8.7 Fan

The unit is equipped with a fan. The fan is temperature regulated, switching on and off as well as the speed are automatically controlled.

The fan prevents excessive heating up of the unit and contributes to the general operational reliability. Failure of the fan is indicated by means of an error message in the display (see error messages). For safety reasons the unit should never be operated without fan. The top cover of the firing chamber and the openings in the rear cover must never be obstructed or blocked.

8.8 Voltage supply failure

The unit is equipped with a voltage failure protection. In case of a short-term voltage supply failure this element prevents a termination of the program with a resulting a firing fault. The voltage failure protection becomes effective as soon as the main voltage fails during a progressing firing program.

Mains voltage failure time less than approx. 10 sec.

The program continues and is not terminated, the display is out of operation for the corresponding period of time. Once the mains voltage is applied again, the display indicates a program interruption for the reason of information, press the confirmation button to reset the message.

Mains voltage failure time longer than approx. 10 sec.

The program is terminated, the display is out of operation. Once the mains voltage is applied again, the display shows Start menu.



After the mains voltage is applied again the time needed to switch the control unit back on is approx. 20 sec.

8.9 Warranty and liability

The warranty and liability depends on the conditions agreed upon by contract.



Changes to the software without the knowledge of and approval by VITA Zahnfabrik H. Reuter GmbH & Co KG cause the exemption from liability and warranty.

8.10 Spare parts

Spare parts must comply with the technical requirements determined by the manufacturer. This is always assured when using original spare parts.

9 Temperature rise

The program shows the temperature rise in °C/Min. and in Min / sec. The input value can be selected in the range from °C/Min (20 °C – 120 °C) or Min/sec. (2:00 – 40:00). The second value is automatically calculated and displayed. The input of values outside the permissible range will not be accepted and the last valid value will be displayed again. If the calculated temperature rise of 20 °C/Min is fallen short of or the top value of 120 °C is exceeded because of the input of a temperature rise value in Min/sec, a valid temperature rise time in Min/sec is automatically entered.

If the pre-dryer temperature or the firing temperature is changed after the input of the temperature rise, the value °C/Min is maintained and the time in Min/sec is adapted accordingly.

10 Automatic temperature adjustment.

The automatic temperature adjustment is performed after each start of a firing program.

This temperature adjustment accounts for or corrects all deviations of electronic components related to temperature measurement and temperature control that have occurred. This adjustment is made in 5 msec., the general course of time is thereby not affected. This ensures a uniform temperature performance of +/- 2 °C, even over a long operating time of the unit.

11 User assigned programs

The control unit is provided with a USB – interface to plug in a Memory Stick .

The Memory Stick can be plugged in and pulled out while the unit is in operation.

If a user has been created on the Memory Stick the system changes over to this user after plugging in.

The display shows the name of the user.

If no Memory Stick is plugged in, VITA will be displayed as user.

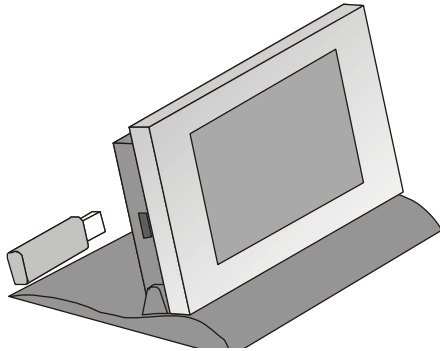

11.1 Changing the user/creating a user

Unit switched on,
main menu is displayed.

- Press button "User" (1)

Plug in the Memory Stick:

- Press button "Change" – the active user is displayed.

or

- Press button "New" – the keypad is displayed.
- Enter the name.
- Press button "OK".

or

- Press button "Delete".
- Press button "OK".

or

- Press button "Change" – the keypad is displayed.
- Enter the name.
- Press button "OK".

- Press button "Main menu" – confirm input

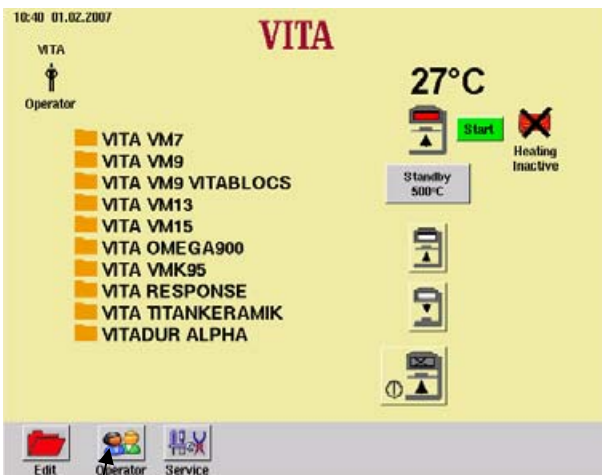

1



12 General operation of unit

The control unit is solely to be operated with the pin supplied for this purpose.

i The use of other means for operation will cause damage to the touch-screen and possible malfunctions.

12.1 Numerical input

i The fields "2", "3" and "4" are only displayed if process data "ON" has been selected in the service menu, see section 23.5.

When clicking on fields for numerical input a keypad is displayed.

Click on a field:

The field is highlighted in colour. The input of a value deletes the existing value.

or

Touch the field with the pin behind the last digit:

The cursor is displayed. Use button "←" to delete the digits one by one.

i Input of time values always with colon, e.g.
 time 0 input = 1:00 (Min/sec.)
 or
 6 Min = 6:00
 Confirm value with "OK".

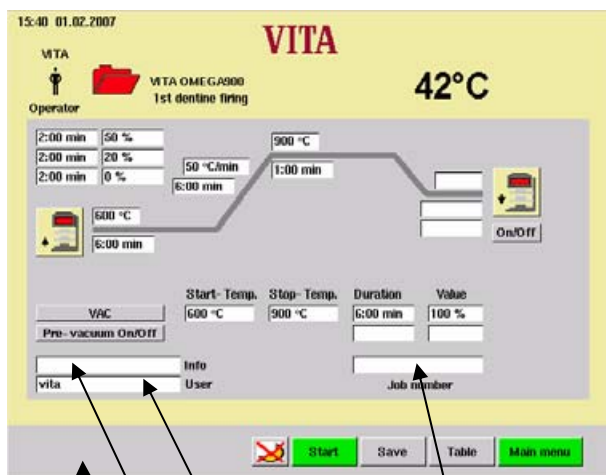

- 1 Info bar
Possible input values are displayed.
- 2 Input of information via scanner or maximum 20 digits
- 3 Input field for user
(maximum 20 digits)
- 4 Input field for job number
(maximum 20 digits)

12.2 Alphanumerical/numerical input

When actuating for alphanumerical inputs the keypad is displayed.

Click on a field:

The field is highlighted in colour. The input of a value deletes the existing value.

or

Touch the field with the pin behind the last digit:

The cursor is displayed. Use button "←" to delete the digits one by one.

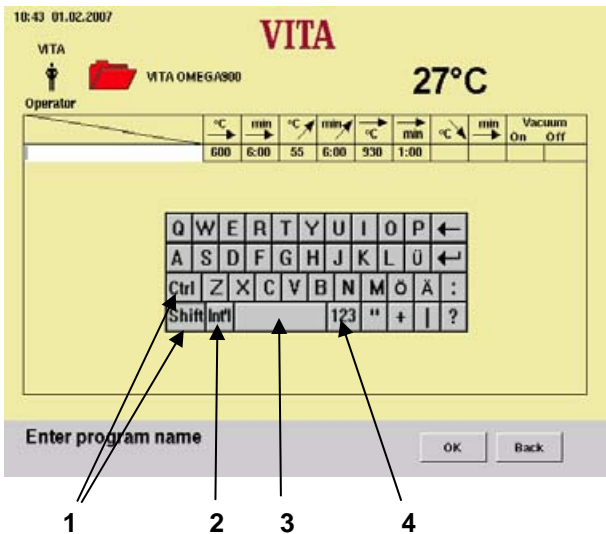

- 1 Shift-key
- 2 Special characters
- 3 Space key
- 4 Changeover key for numbers

12.3 Quickstarting a firing program – Quick-start

Quickstart is displayed if the firing chamber temperature is still higher than the selected pre-drying temperature when starting a firing program.

The opposite display appears on the screen.

The smaller temperature difference between pre-dryer temperature and end temperature results in a shorter rise time.

The temperature gradient is maintained and the adapted rise time is displayed.

Pressing button "Yes" starts the program immediately, when pressing button "No" the program is started after the firing temperature has reached the pre-drying temperature.

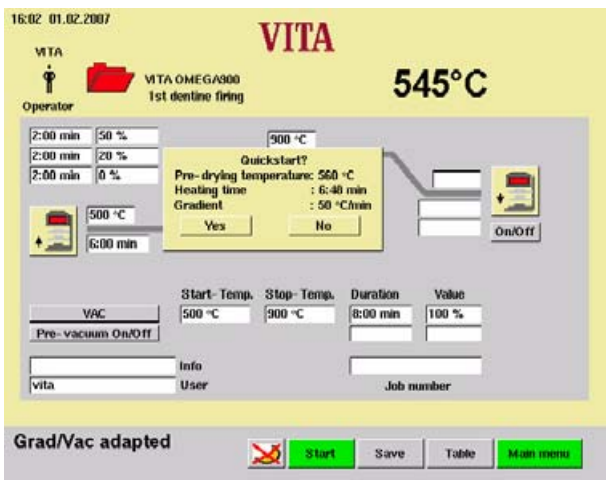

13 Start menu

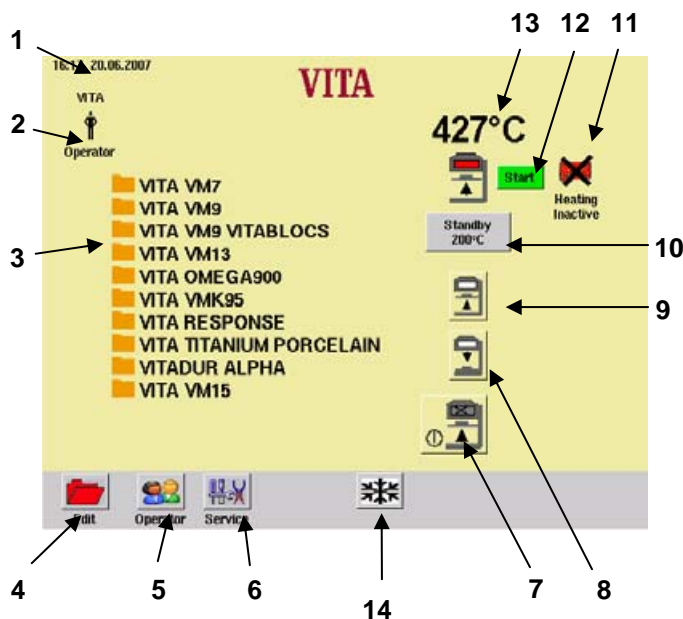

The control unit is solely to be operated with the pin supplied for this purpose.

The use of other means for operation will cause damage to the touchscreen and possible malfunctions.

After switching on the unit the display shows the main menu.

- Switch on the unit by the main switch.
- The lift moves to bottom position
- The main menu is displayed.
- Select the program group.
Maximum 12 groups are displayed.
If more groups have been created the scroll bar will appear on the right hand side of the screen.

- 1 Date/Time
- 2 User name
- 3 Program groups
- 4 Edit program group
- 5 Change user
- 6 Change to Service programs
- 7 Shut down unit
- 8 Lift button down
- 9 Lift button up
- 10 Change standby temperature
- 11 Heating off
- 12 Start = standby
- 13 Firing chamber temperature
- 14 Quick cooling (see section)

14 Standby

14.1 Adjustment of standby temperature

Press button "Standby" in the start menu.

- Enter a value via the numerical keypad (1).
- Press button "OK" (2) to confirm or "Cancel" (3) without changing the temperature.

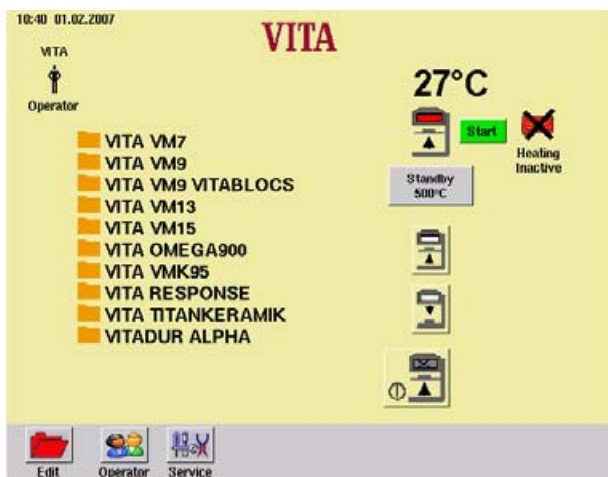
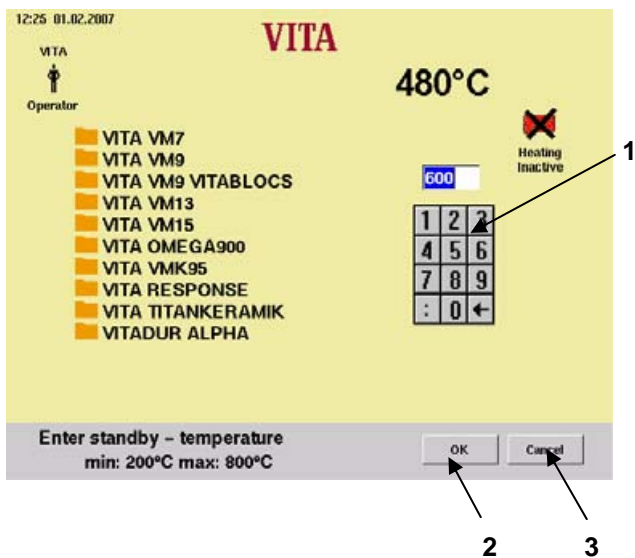

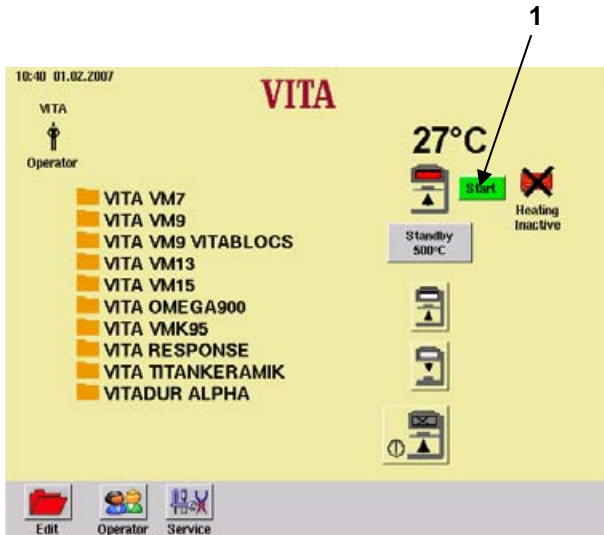

14.2 Start/stop standby mode

- Press button "Start" (1) in the start menu, the lift moves to top position, the heating is active.
- Press button "Open" (2), switch on the heating, the lift moves down to bottom position.

OR

- Press button "Stop" (3), quit standby mode, switch off the heating, the lift moves down to bottom position.

OR

- Press button "Close" (4), switch on the heating, the lift moves up to top position.

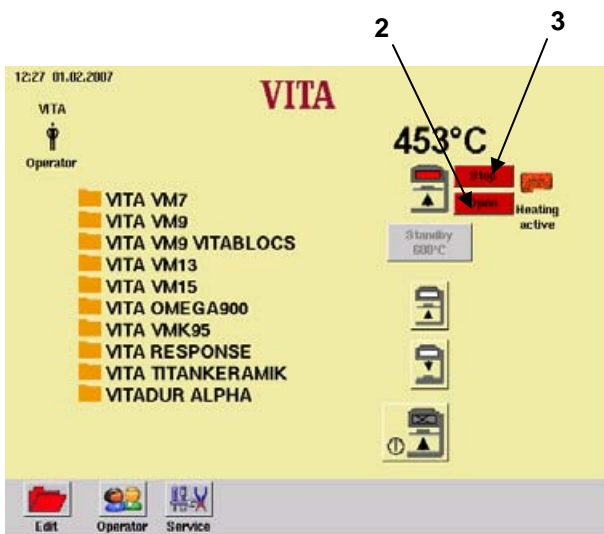

If no further operation takes place within 5 minutes the heating will switch off.

In standby mode the following functions are available for selection:

- Lift buttons
- Program group for firing program
- Edit
- User
- Service
- Shut down unit

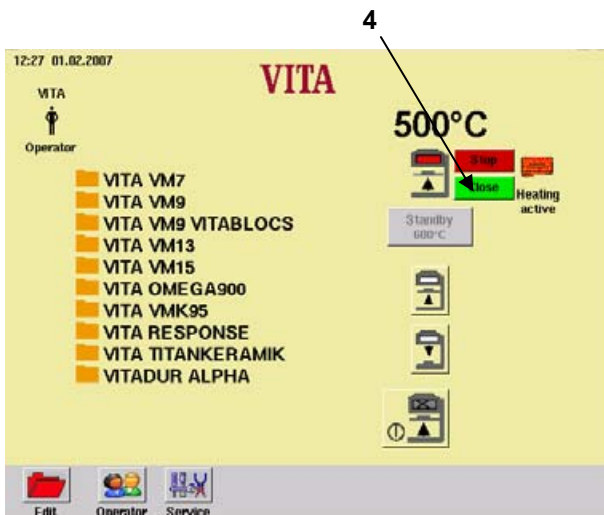

15 Selecting a firing program



- Select one of the displayed program groups (1) from the start menu.

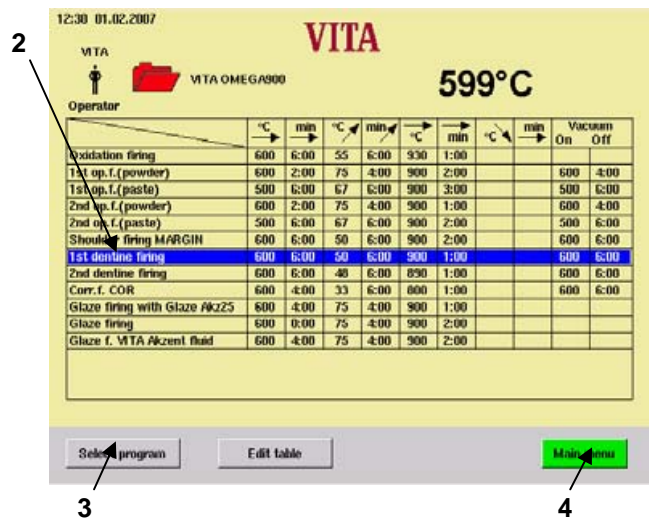

- Choose the desired program in the firing table (2).
- Press button "Select program" (3) to select the program.

or

- Press button "Main menu" (4) to return to the start menu.

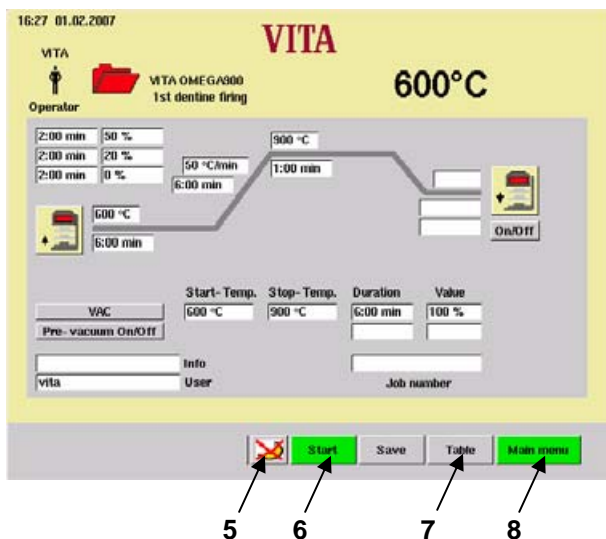

- i Night program (5):**

After expiration of the program and cooling down to 200 °C the lift is retracted and the display switched off.

Press button (5).

Active night mode is indicated.

- Press button "Start" (6) to start the program.
- Press button "Table" (7) to return to the firing table.
- Press button "Main menu" (8) to return to the start menu.

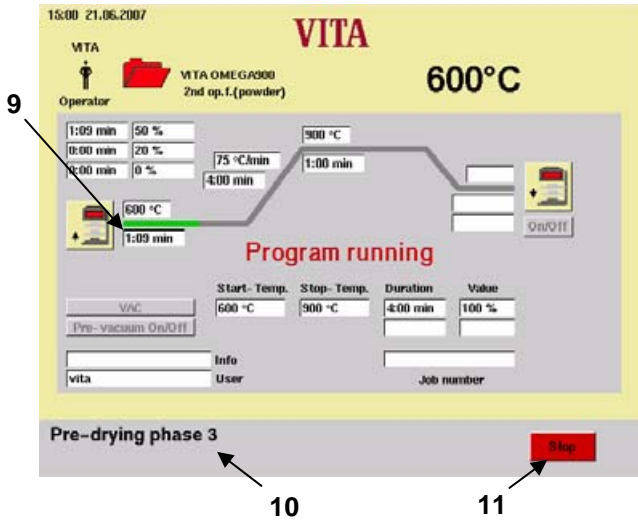

The Info bar (10) shows the active program section.

The chronological sequence is displayed green in the firing curve (9).

- Press button "Stop" (11) to terminate the program.

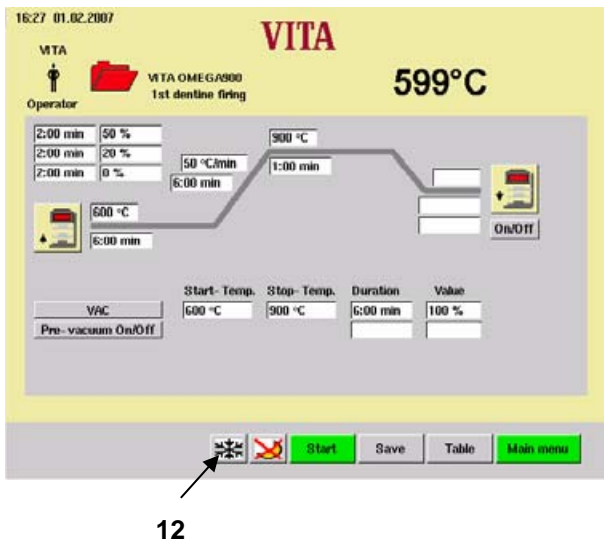

Press button "OK" after the end of the program

Quick cooling (12):

The pump is switched on, at a firing chamber temperature of 50 °C below the standby temperature the lift is retracted and heated up again to standby temperature.

The symbol "Quick cooling" (12) is only displayed if the temperature in the firing chamber is higher than the standby temperature.

16 Changing program values

Time and temperature values as well as vacuum activation and deactivation values can be changed in graphics and tabular mode.

Values for lift positions pre-drying, cooling, vacuum value and pre-vacuum are changed in graphics mode.

16.1 Changing program values in graphics mode

- Select the program group in the start menu.
- Select the program.

The process for changing program values is explained on the example for changing the pre-drying time.

- Press button "Pre-drying time" (1).

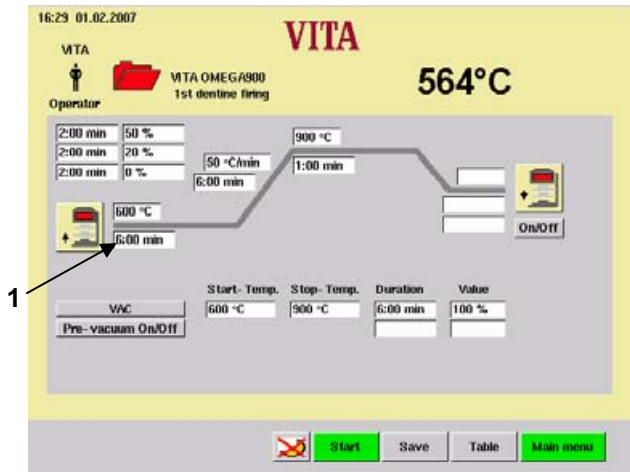

The field is highlighted. The Info bar (2) shows the possible input values.

- Enter a value via the numerical keypad (4).
- Press button "OK" (3) to confirm.

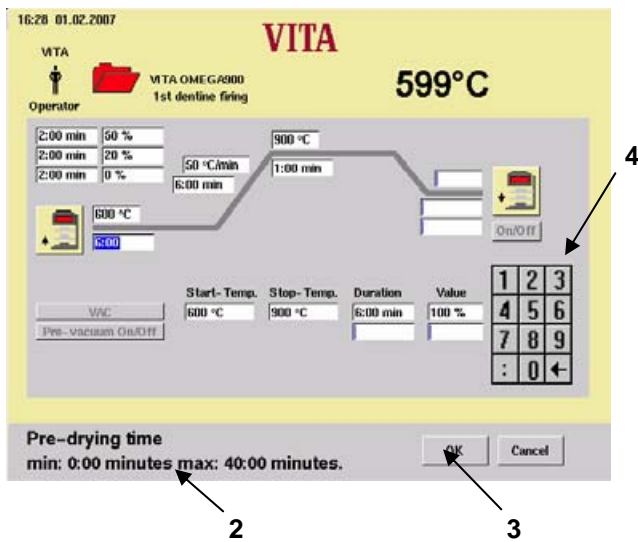



5 6

Do not save value

- Press button "Start" (5).
- Press button No
 The program runs with changed values.
 After the sequence return to the originally saved value.

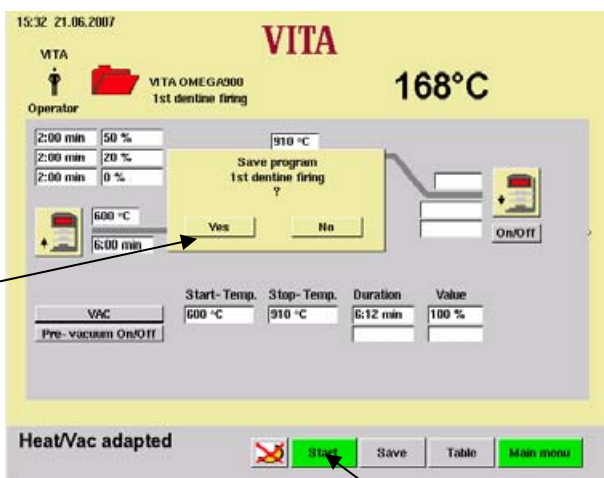

7
 8

Save value

- Press button "Save" (6).
- Press button Yes (7)
- Press button "Start" (8).

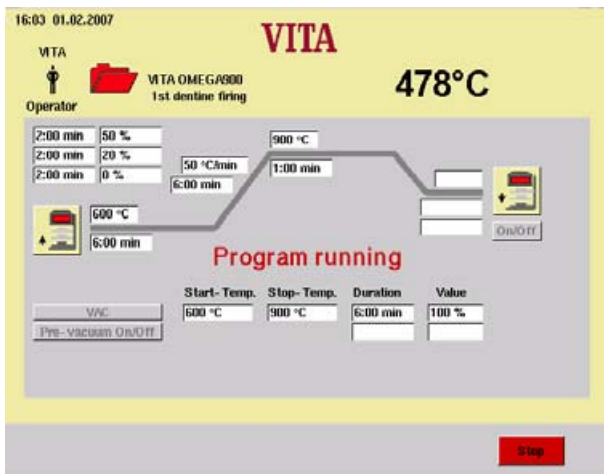

The program runs with the specified values.
 This sequence applies for all changes to all program values in graphics mode.

16.2 Changing program values in tabular mode

- Select the program group in the start menu.

The process for changing program values is explained on the example for changing the pre-drying time.

- Select the program (1).
- Press button "Edit table" (2).

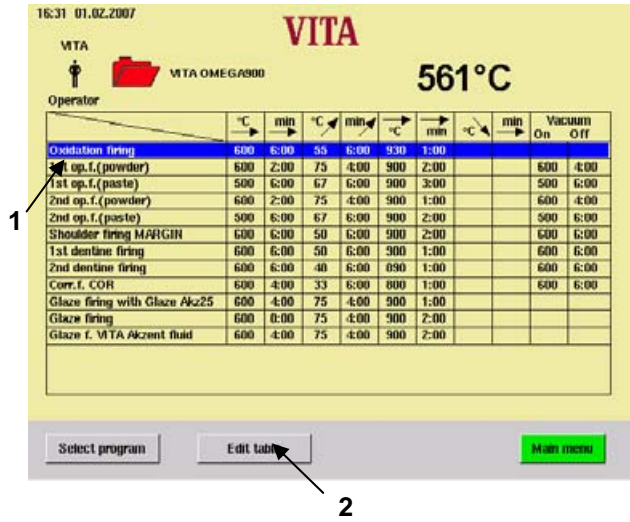

- Press button "Change" (3).

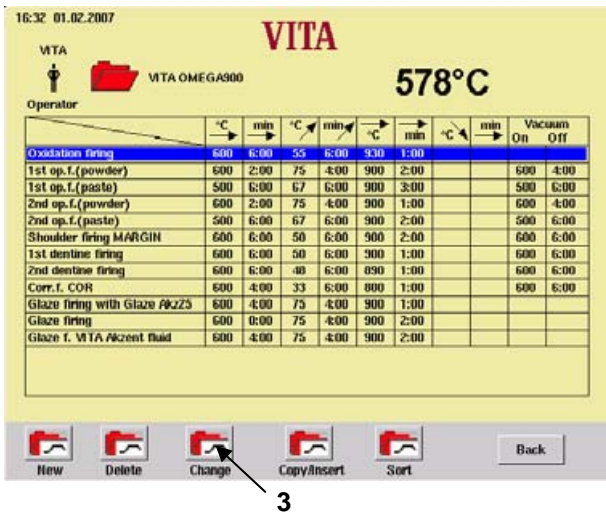

- Select field "Pre-drying time" (4).

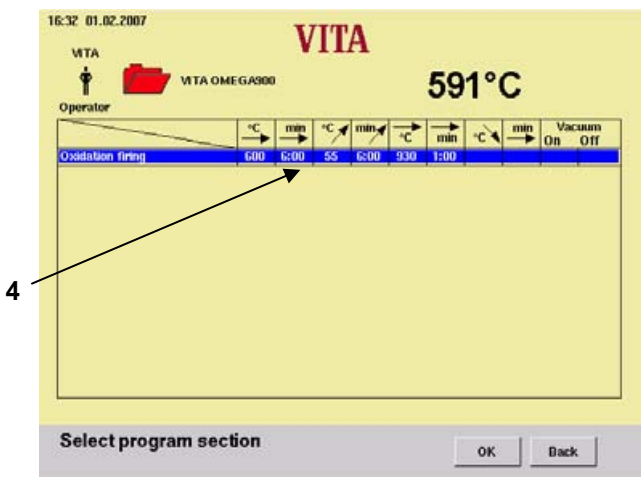

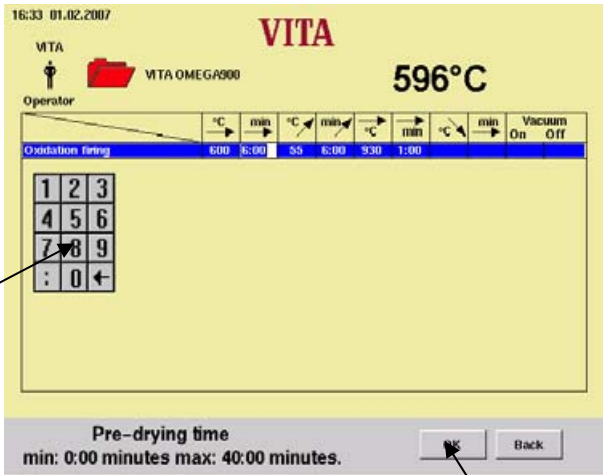

- Enter a value via the numerical key-pad (5).
- Press button "OK" (6).
- Change other values as required.

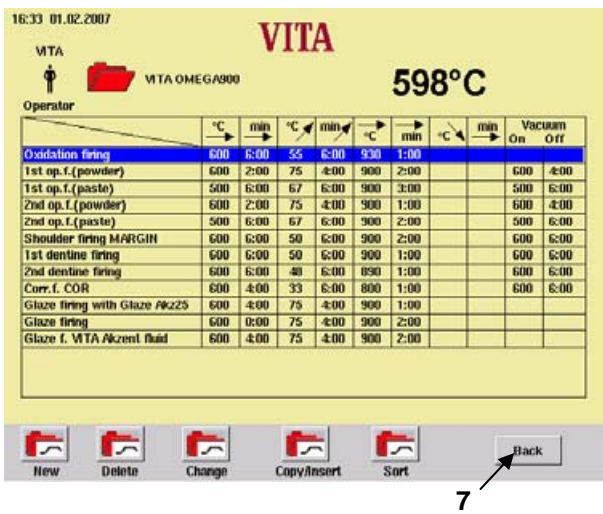

- Press button "Back" (7).
- Values changed in tabular mode are saved.

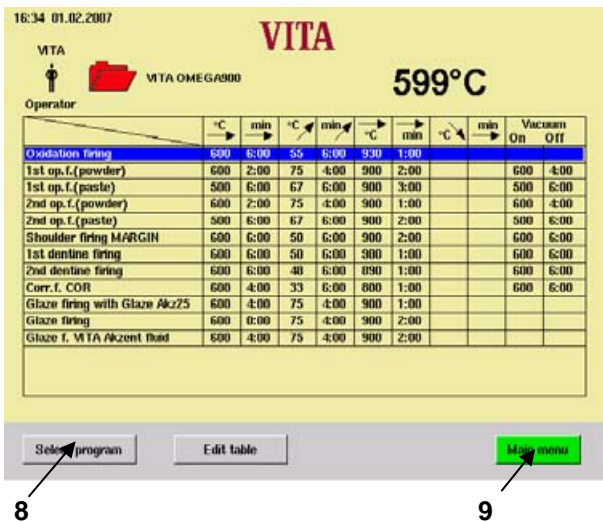

- Press button "Select program" (8).
- or
- Press button "Main menu" (9).

This procedure applies for changing all values of a program in tabular mode.

17 Lift positions and position times for pre-drying

For the pre-drying phase 3 lift positions are available.

- Pos. 1 – bottom position – the possible input value is 0 – 30 %, the time value 0 – 2:00 Min.
- Pos. 2 – middle position – the possible input value is maximum 50 %, the time value 0 – 2:00 Min
- Pos. 3 – top position – the input value is maximum 80 %, the time value is the difference to the pre-drying time and is determined and entered automatically.

The basic values ex factory are:

- Pos. 1 = 0 % time = 2:00 Min.
- Pos. 2 = 20% time = 2:00 Min.
- Pos. 3 = 50% time = 2:00 Min. The time is automatically determined.

When changing a pre-drying time by more than 6:00 Min the time for Pos. 1 and Pos.2 is maintained and the time for Pos. 3 is extended accordingly.

When changing the pre-drying time by less than 3:00 Min pre-drying is executed in Pos. 2 with lift position 50 %.



17.1 Direct input of changes for lift position and position time.

- Select the program group in the start menu.
- Select the program.

Example: Change of lift position 1:

- Actuate the field "Lift position 1" (1).

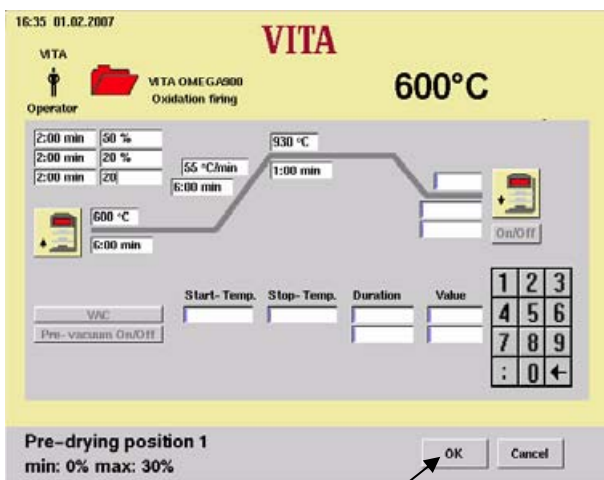

- Enter the value.
- Press button "OK" (2).

2

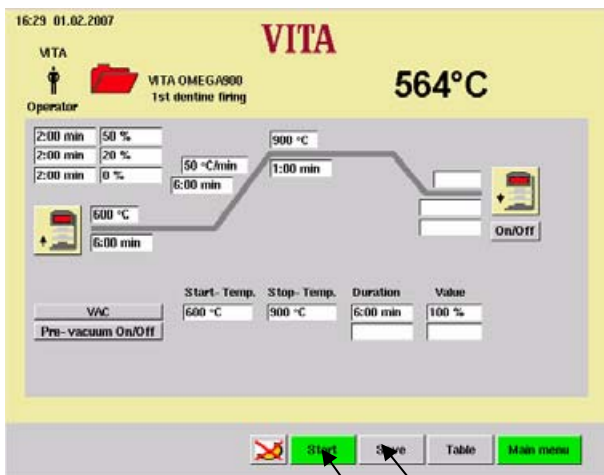

Do not save value

- Press button "Start" (3).
The program runs with changed values.
After the sequence return to the originally saved value.

Save value

- Press button "Save" (4).

3

4

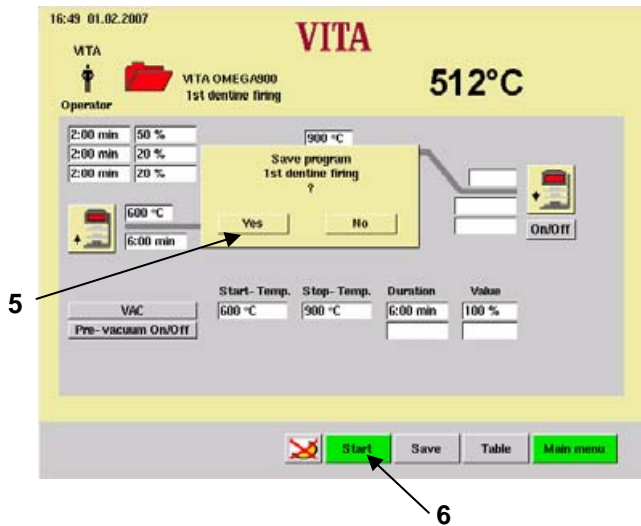

- Press button "OK" (5).
- Press button "Start" (6).



The program runs with the specified values.
This sequence applies for all changes to all program values in graphics mode.



17.2 Input of changes to lift position and position time in the pre-drying menu .

- Select the program group in the start menu.
- Select a program.
e.g. change of lift position 1.
- Press symbol "Pre-drying" (1).
- Press symbol "Lift position" (2).
The lift travels to position 1, 2 or 3.
The fields Pos. and Time belonging to the position are highlighted in colour, except the Time for Pos. 3. This is automatically determined, inputs are not possible.

The positions are changed as follows:

- Actuate the large symbol (2), select the desired position 1, 2 or 3 (2), the lift travels to the stored position.
- Move the lift to the desired position by pressing the button "Lift up" or Lift down".
- Press button "OK".

or

- Actuate the position field.
- Enter the value via the keypad.
- Press button "OK".
- Actuate the large symbol to enter the next lift position.

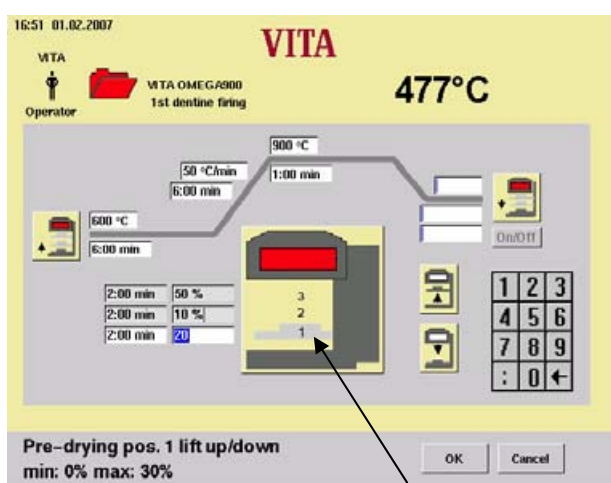

2

Changes for a program sequence:

- actuate the small symbol.
- Press button "Start".

Save changes:

- Press button "Save".
- Press button "Yes".
- actuate the small symbol.

The pre-drying position menu can be closed at any time by actuating the small symbol.

The same sequence is used to enter the position times.

The possible input values are displayed in the Info bar.

18 Lift positions for cooling

- Select the program group in the start menu.
- Select the program.
- If cooling is not activated press button "Cooling On/Off" (1), basic values are displayed.

18.1 Direct input of changes to the lift position cooling

- Press button "On/Off" (1) to activate cooling.

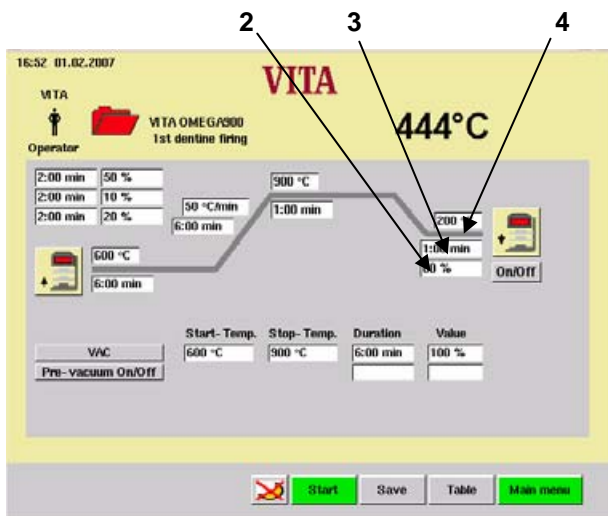
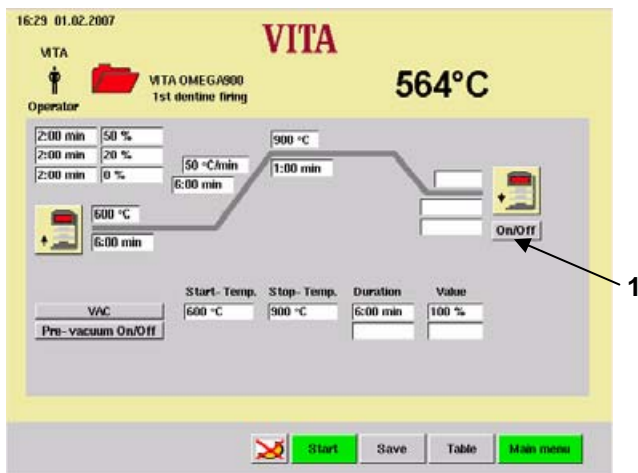

- 2 Input field for holding time
- 3 Input field for lift position
- 4 Input field for cooling temperature

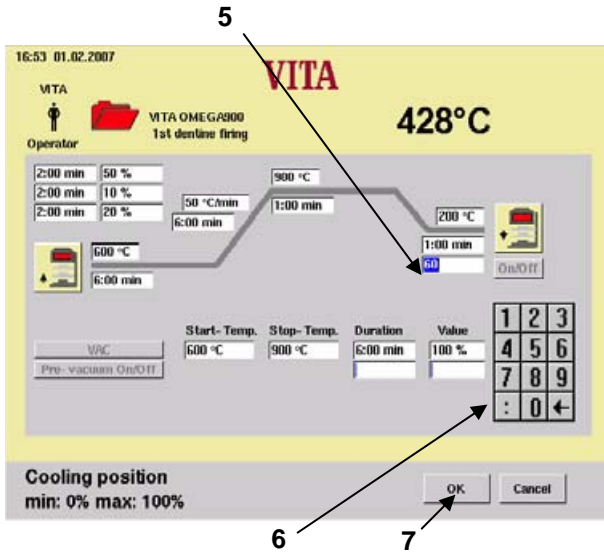

- Actuate the field for "Lift position" (5), the keypad (6) is displayed.
- Enter the value.
- Press button "OK" (7).

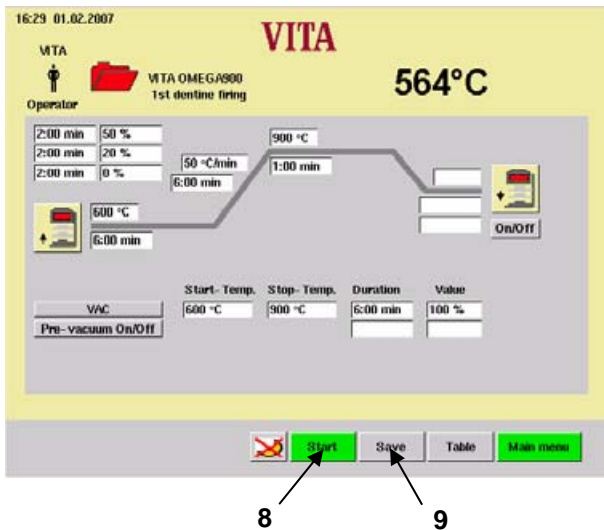

- Press button "Start" (8).
After expiration the original value is restored.
- or
- Press button "Save" (9).
- Press button "Yes".
(Button "Yes" is displayed after the button "Save" has been actuated).

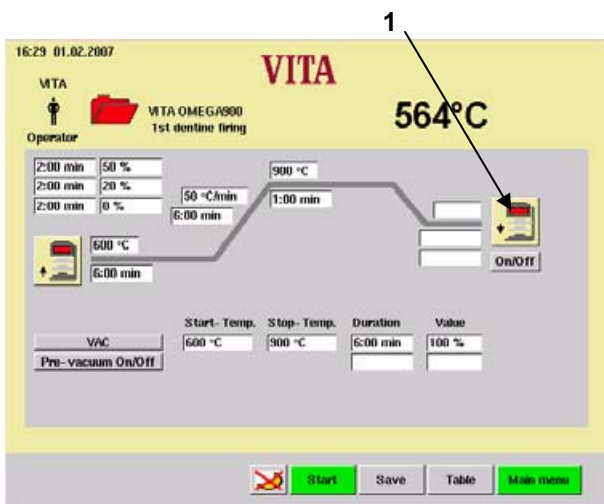

18.2 Entering changes to the lift position in the cool down menu

- Press symbol "Cooling" (1).
("Cooling" must be active.)

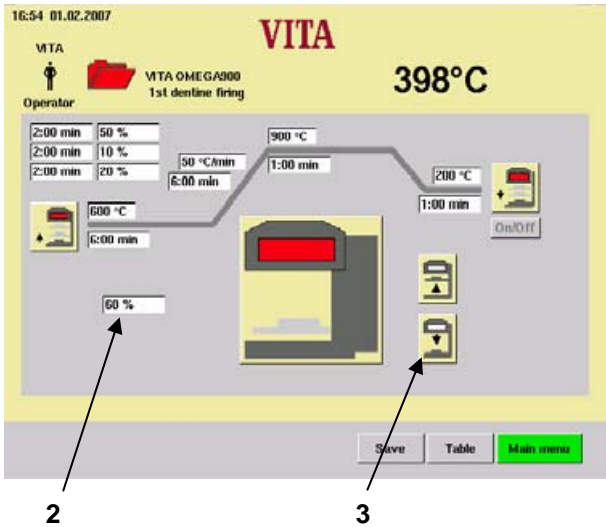

Press input field "%" (2) or button "Lift" (3).

- Enter the value (6).

or

- Press button "Lift up" or "Lift down" (4).

- Press button "OK" (5).

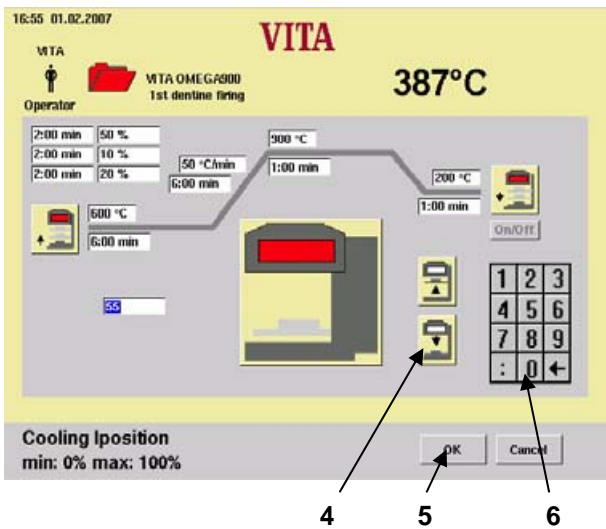

- Press symbol "Cooling" (7).
Start the program with changed value.
After expiration the original value is restored.

or

- Press button "Save" (8).
- Press button "Yes".
(Button "Yes" is displayed after the button "Save" has been actuated).
- Press symbol "Cooling" (7).
- Start the program with changed value.

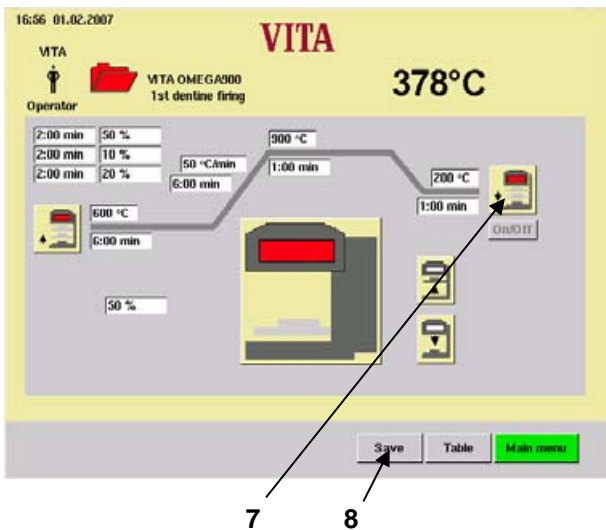

19 Vacuum settings

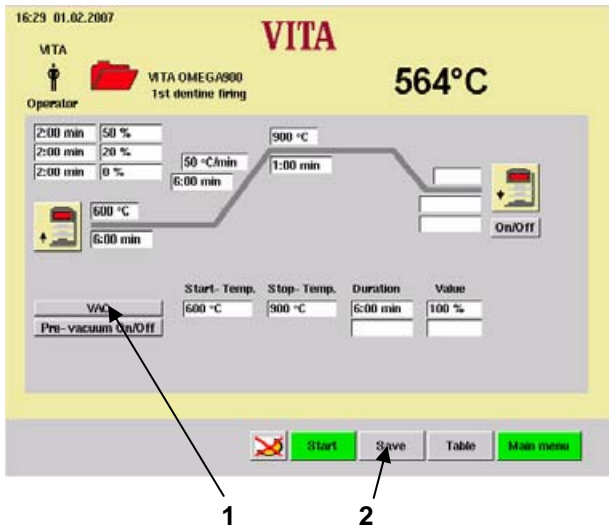

- Select the program group in the start menu.
- Select the program.
- Press button "Main vacuum On/Off" (1) Activate/deactivate vacuum.
- Press button "Save" (2).

When choosing "On" the basic values will be accepted.

"On" = with start of temperature rise.

"Off" = expiration of temperature rise.

"Vacuum value" = 100 %

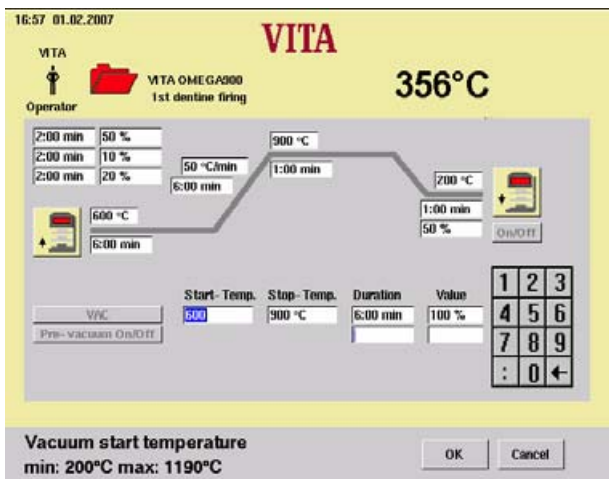

Example: Change of start temperature

- Actuate the field "Start", the keypad is displayed.
- Enter the value.
- Press button "OK", the image changes. Start the program with changed value. After expiration the original value is restored.

or

- Press button "Save".
- Press button "OK".



In case of program changes, for pre-drying temperature/start temperature, end temperature and rise time the times for switching on and off are automatically adapted.

The pump running time is identical with the rise time.

The vacuum display shows the value in %. On the basis of atmospheric pressure of 1000 mbar at sea level:

100%	=	- 1000 mbar (cannot be reached)
95%	=	- 950 mbar or 50 mbar absolute
90%	=	- 900 mbar or 100 mbar absolute

The vacuum value reached depends on the power of the vacuum pump used and is in the range from 85 - 95% (150 mbar - 50 mbar absolute)

If the vacuum value of 30 % within a period of approx. 15 seconds during the course of a firing program, the firing program will be aborted and the error message Vacuum within 15 s < 30 % is displayed (see section 27 "Error messages").

Formation of condensation water in the firing chamber insulation and in the vacuum pump results in a lesser vacuum and therefore to poorer firing results.

For this reason the lift should be retracted when the unit is switched off, thus to avoid the absorption of moisture.

20 Pre-vacuum adjustment

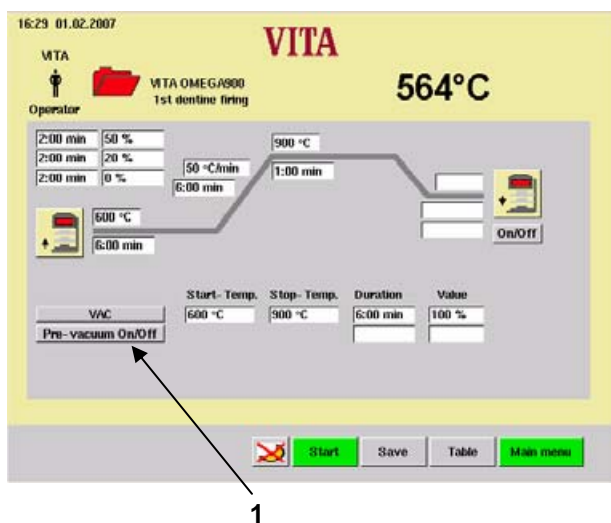

- Select the program group in the start menu.
- Select the program.
- Actuate the field "Pre-vacuum" (1) – activate/deactivate pre-vacuum.
- Actuate the field "Duration" or "Value", the keypad is displayed.
- Enter the value.
- Press button "OK".
Start the program with changed value. After expiration the original value is restored.

or

- Press button "Save".
- Press button "OK".

The setting "Pre-vacuum" assures that a vacuum is already effective in the firing chamber, before the temperature rise becomes active.

21 Creating program groups

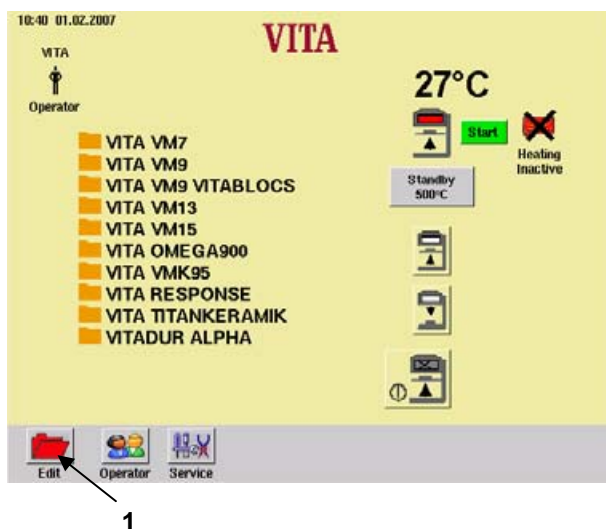

- Press button "Edit" (1) in the start menu.



When creating program groups on the Memory Stick you should change to the main menu before pulling out/plugging in.



- Press button "New" (2).

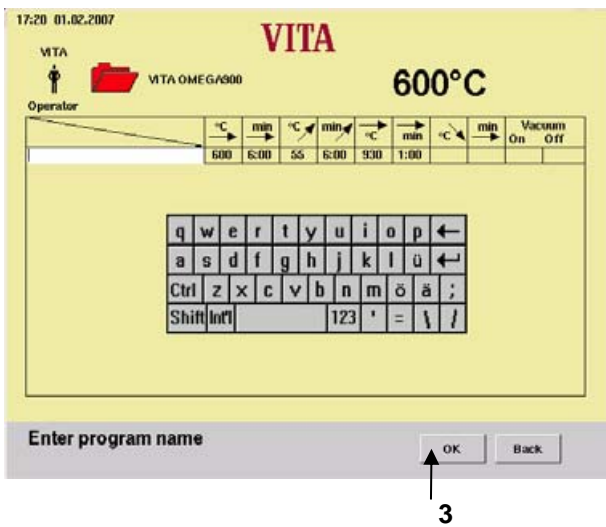

- Enter the program name, e.g. Test (see also section 12.2).
- Press button "OK" (3).

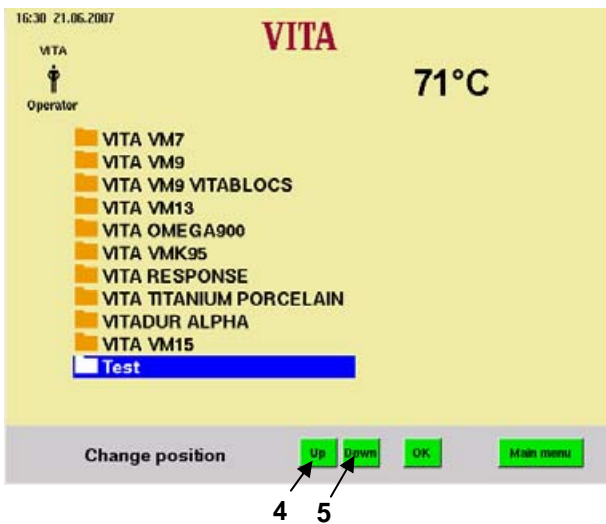

- Press button "Up" (4) or "Down" (5).
- Press button "OK" or "Main menu".

21.1 Deleting program groups.

i Deleting a program group also deletes the associated firing program.

- Press button "Edit" (1)

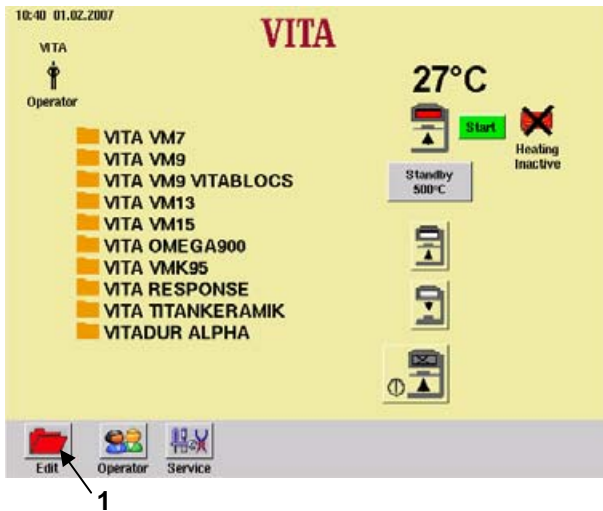

- Press button "Delete" (2).

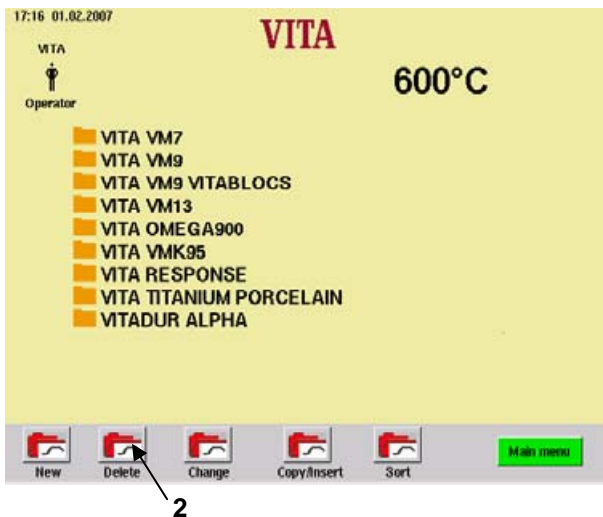

- Select the program group (3).
- Press button "OK" (4).

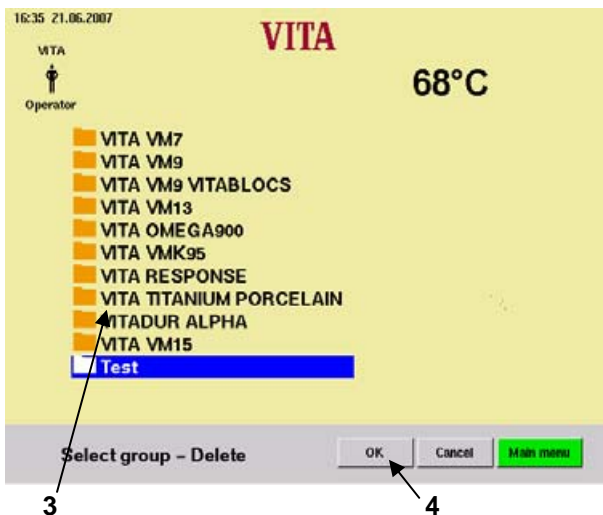

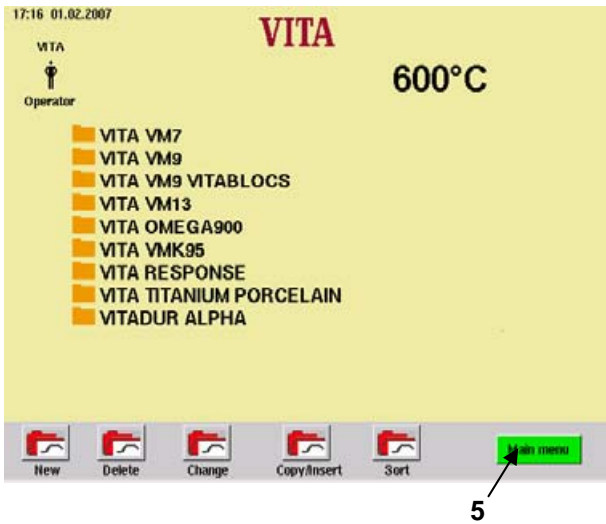

- Press button "Main menu" (5).

21.2 Changing a program group

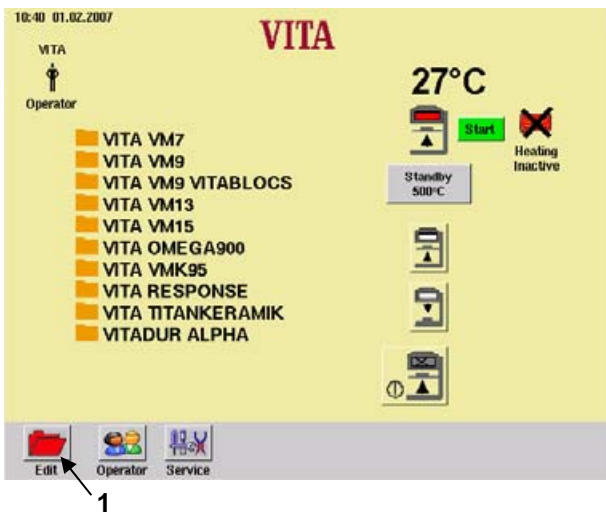

- Press button "Edit" (1)

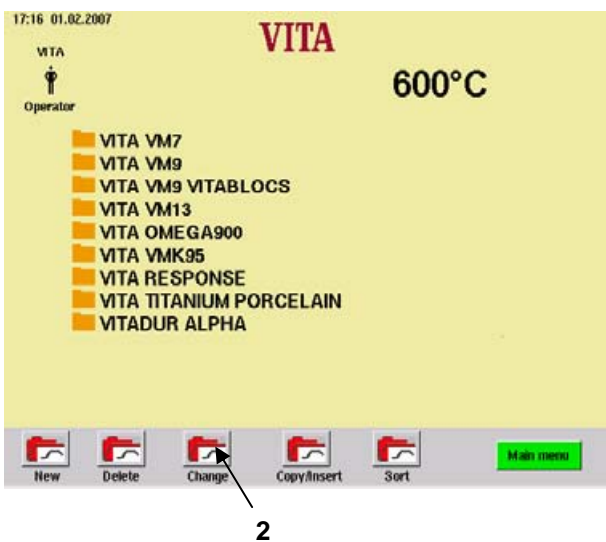

- Press button "Change" (2).

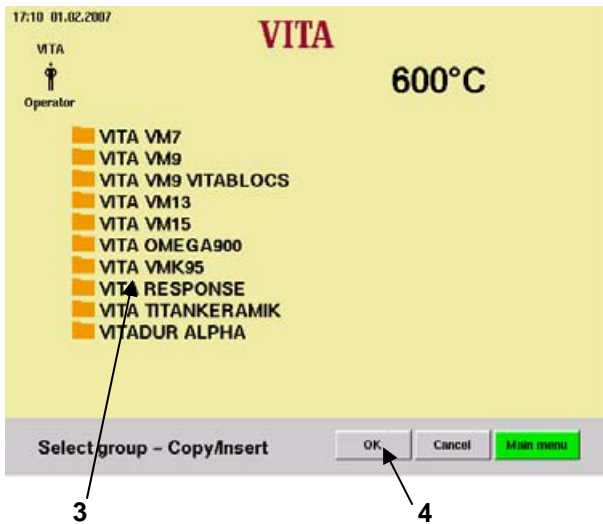

- Select the program group (3).
- Press button "OK" (4).

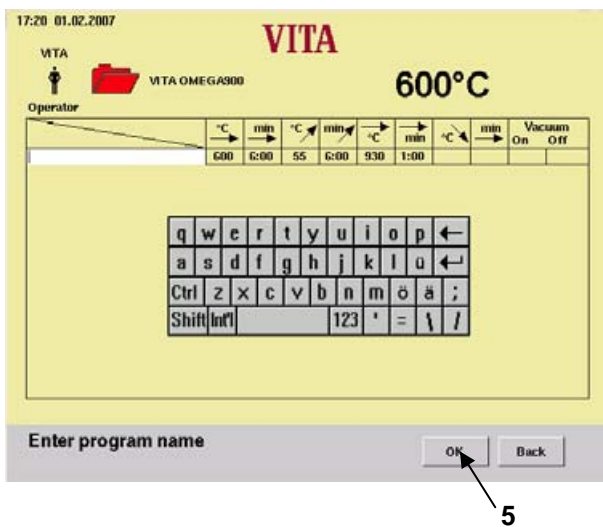

- Enter the program name (see also section 12.2).
- Press button "OK" (5).

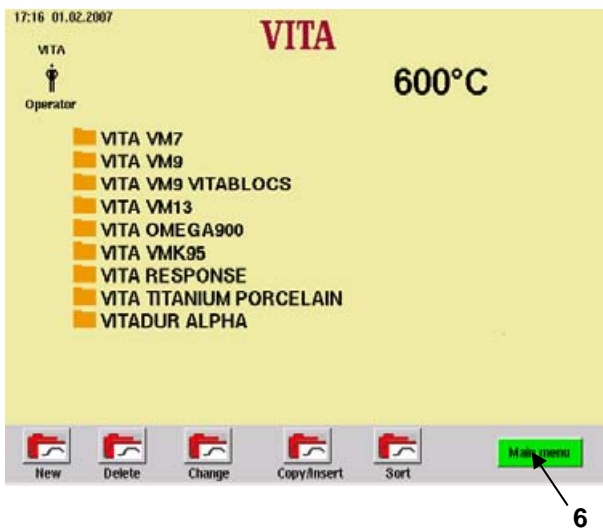

- Press button "Main menu" (6).

21.3 Copying/inserting a program group

- Press button "Edit" (1) in the start menu.



- Press button "Copy/Insert" (2).



2

- Select the program group (3).
- Press button "OK" (4).

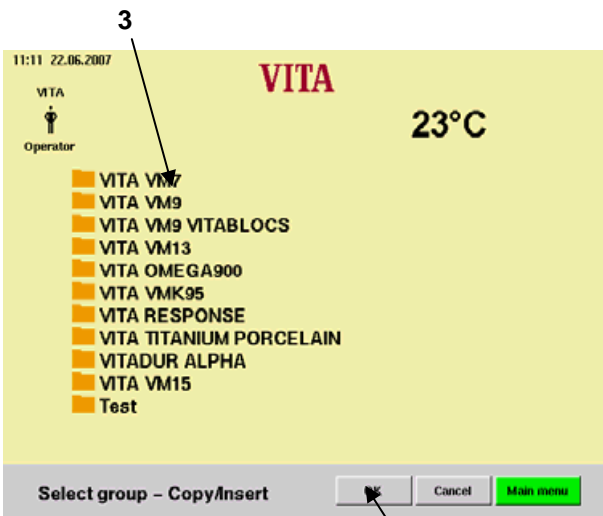

4

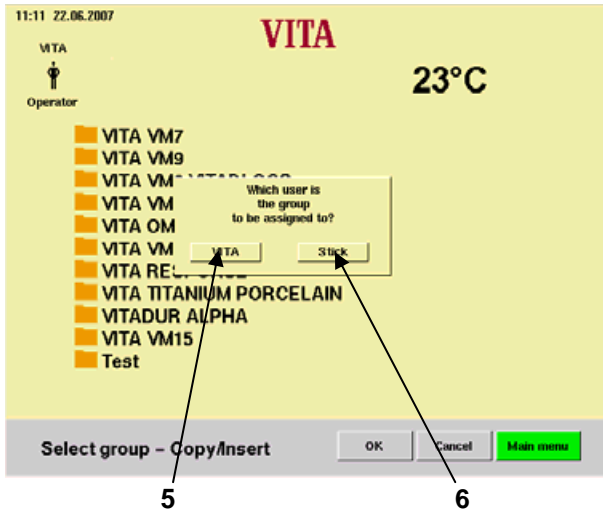

- Press button "Stick" (6) or "VITA" (5).

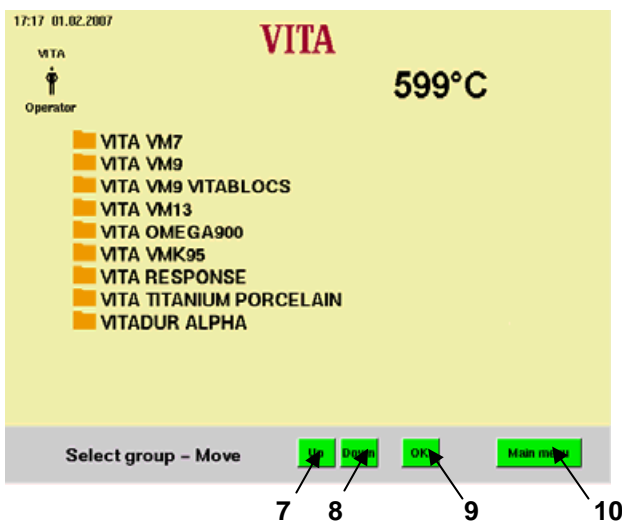

- Sort with buttons "Up" (7) or "Down" (8).
 - Press button "OK" (9).
- or
- Press button "Main menu" (10).

When inserting a program group with the same name a number will be added.

21.4 Sorting program groups

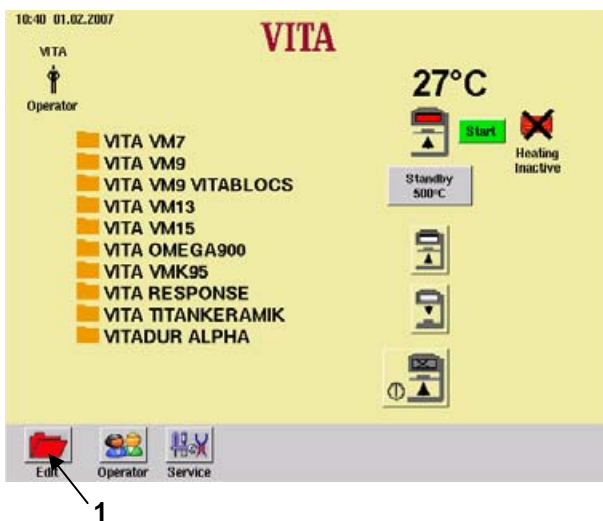

- Press button "Edit" (1) in the start menu.

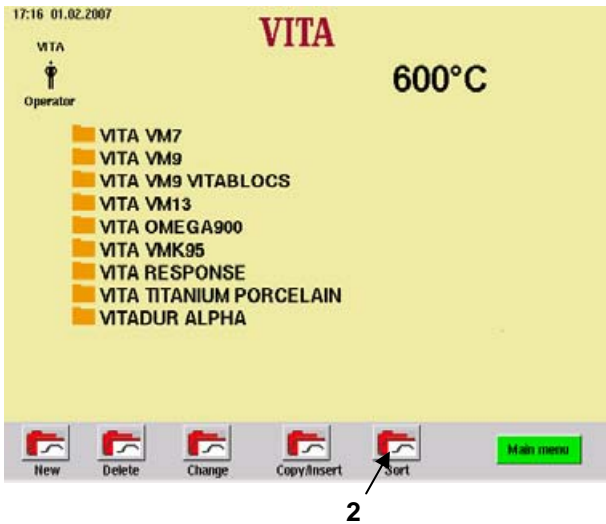

- Press button "Sort" (2).

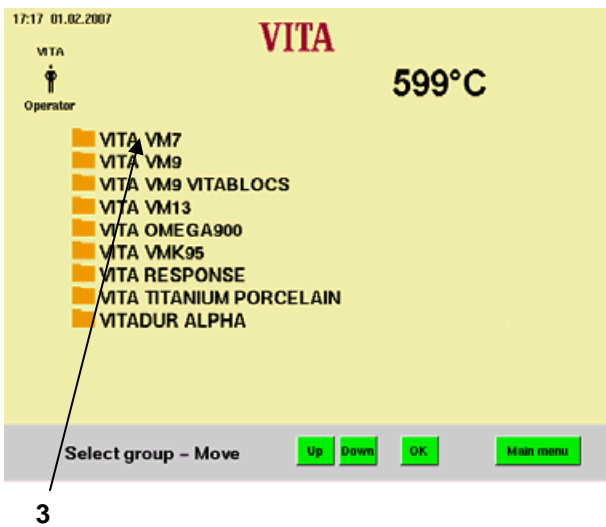

- Select the program group (3).

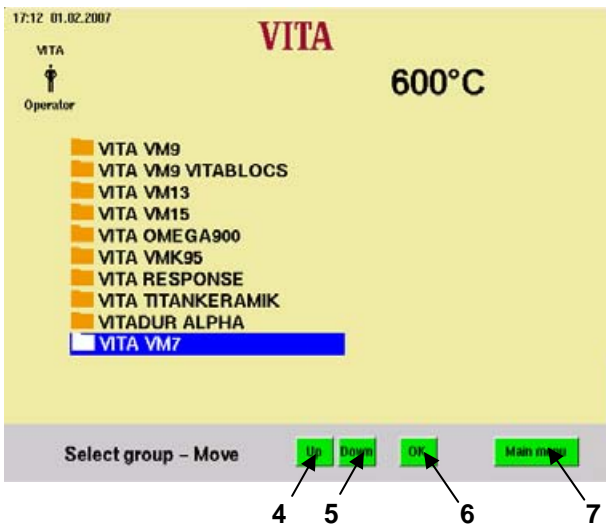

- Move the group with buttons "Up" (4) or "Down" (5).
 - Press button "OK" (6).
- or
- Press button "Main menu" (7).

22 Creating new firing programs

If a new program group is to be created first, refer to section 21.

- Select the program group in the start menu (1).

i When creating program groups on the Memory Stick you should change to the main menu before pulling out/plugging in.

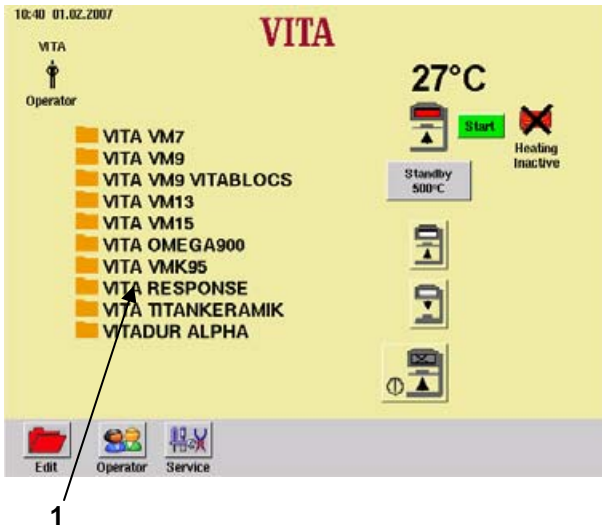

- Press button "Edit table" (2).

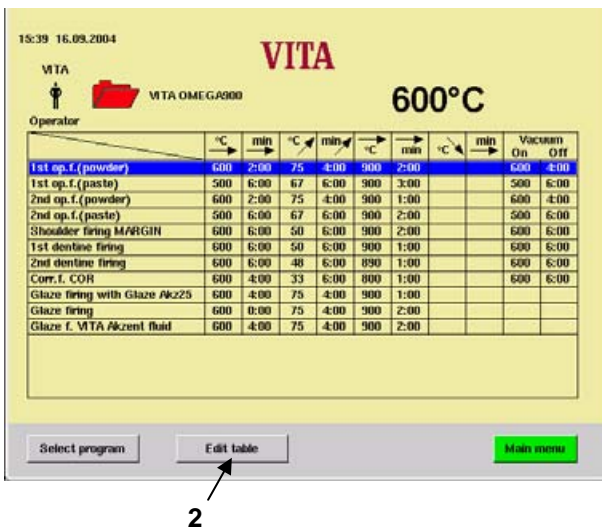

- Press button "New" (3).

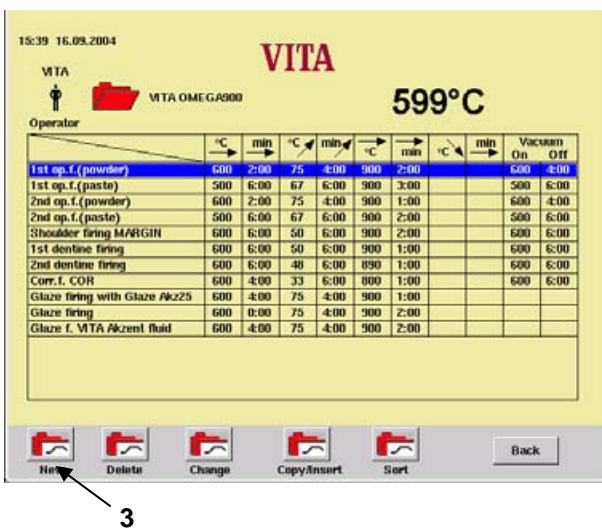

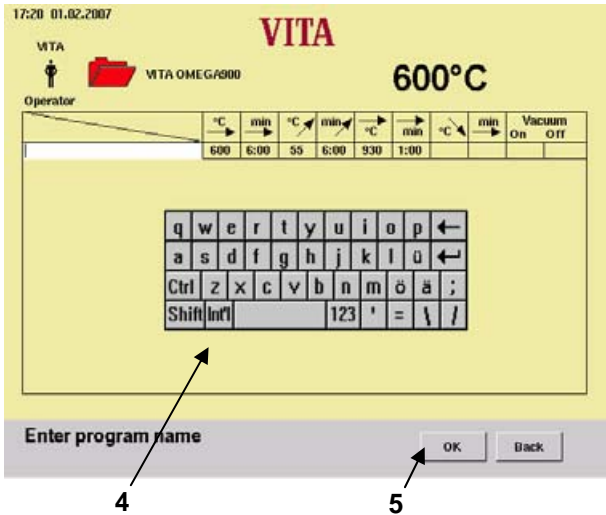

- Enter a program name via the keypad (4).
- Press button "OK" (5) to confirm.

The program offers basic values by default.
For changing refer to section 22.2.

- Press button "Back" (6).

The programs offer basic values by default.

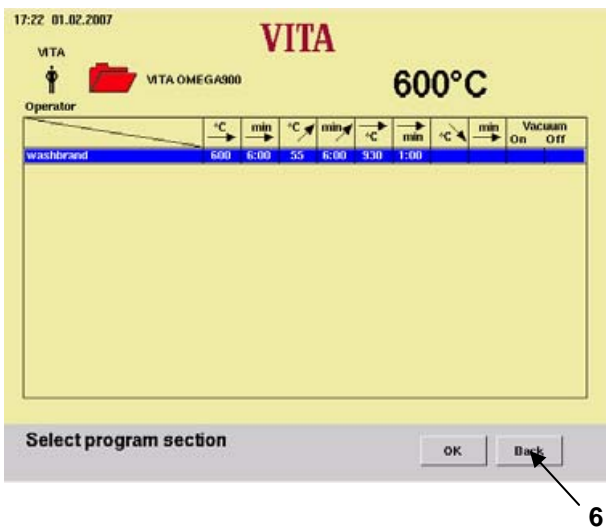

- Make other adjustments as necessary, see section 0.
- Press button "Back" (7).



22.1 Deleting firing programs

- Select the program group in the start menu (1).

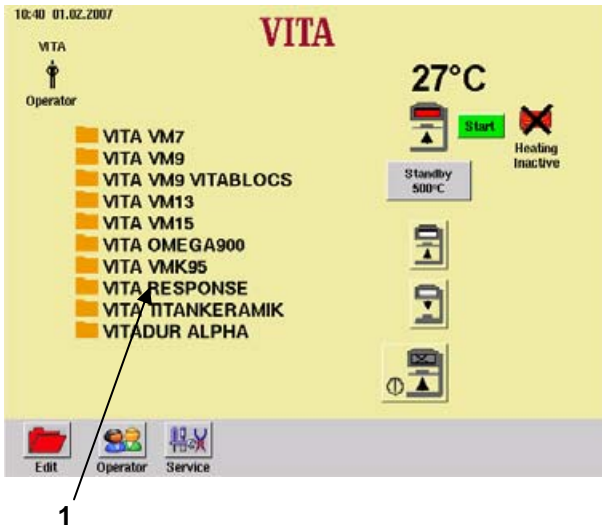

- Press button "Edit table" (2).



- Press button "Delete" (3).



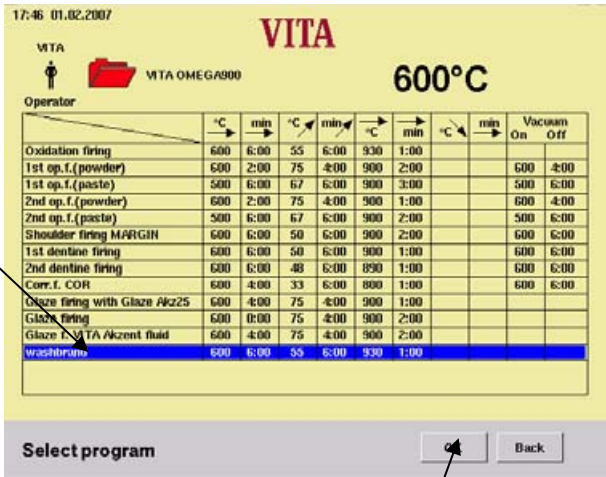

- Select the program to be deleted (4).
- Press button "OK" (5).

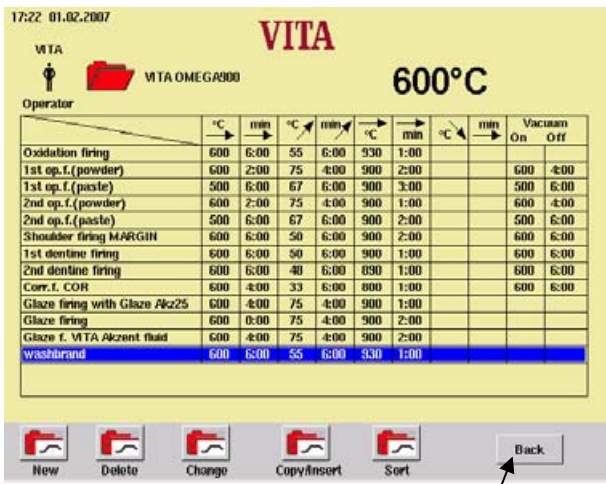

- Select further programs to be deleted.
- or
- Press button "Back" (6).

22.2 Changing firing programs

- Select the program group in the start menu (1).

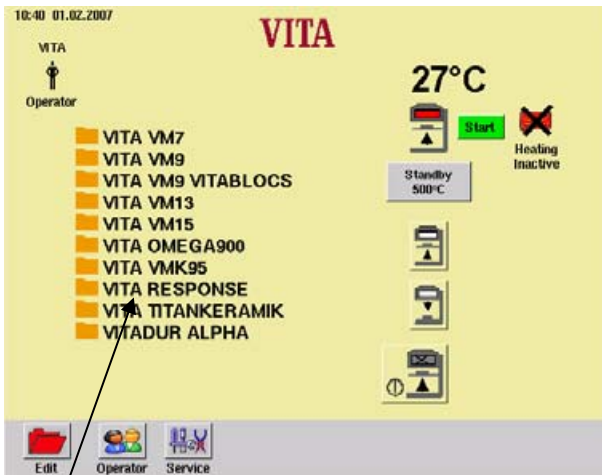

1

- Press button "Edit table" (2).

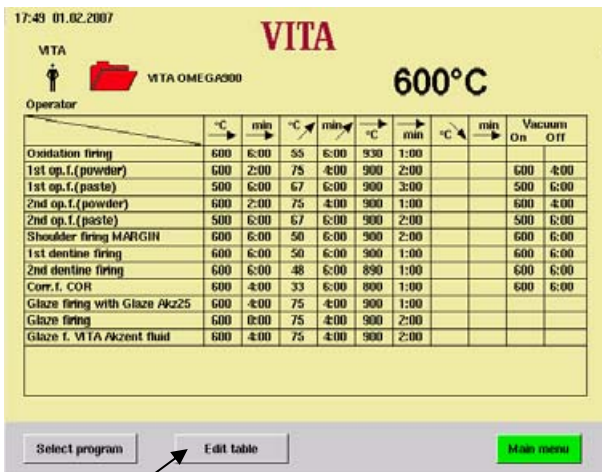

2

- Press button "Change" (3).



3

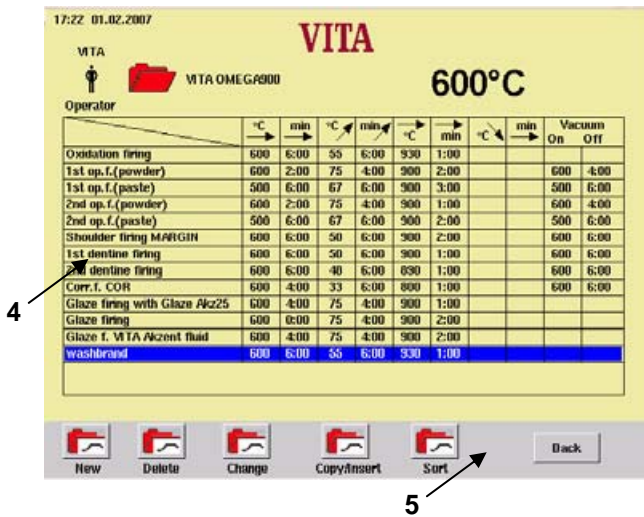

- Select the program to be changed (4).
- Press button "OK" (5) to confirm.

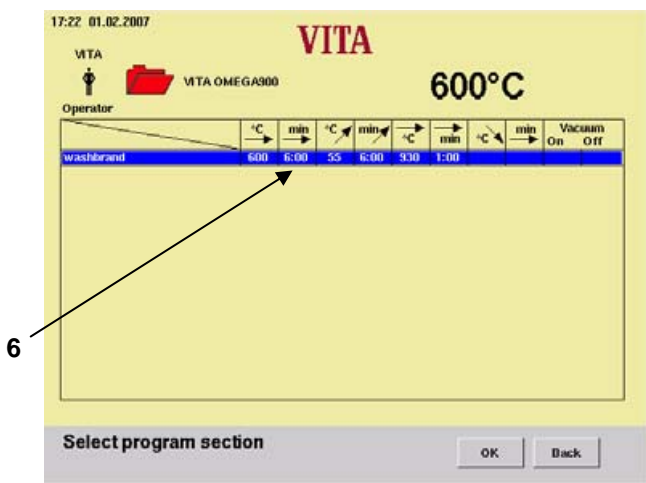

- Example: Changing the pre-drying time:
- Press button "Pre-drying time" (6).

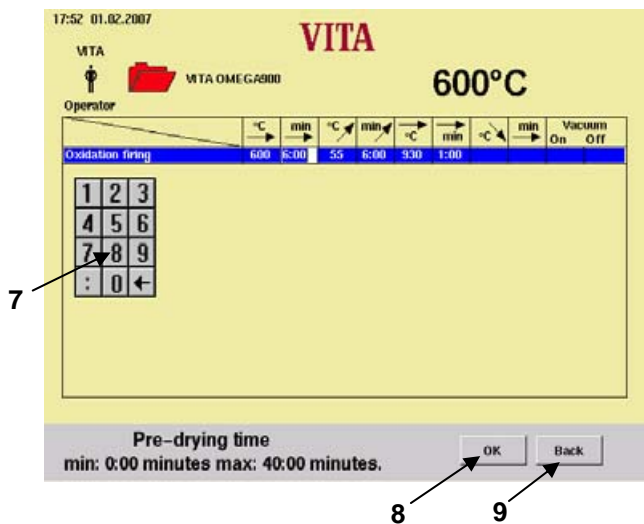

- Enter a value via the keypad (7).
 - Press button "OK" (8).
 - Change further values.
- or
- Press button "Back" (9).

22.3 Copying/inserting firing programs

- Select the program group in the start menu (1).

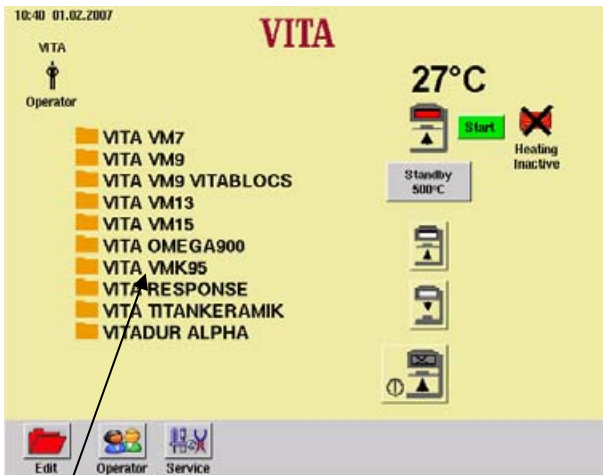

- Press button "Edit table" (2).

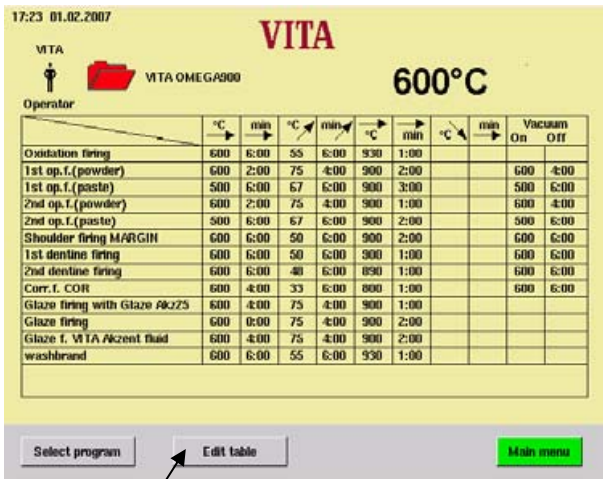

- Press button "Copy/Insert" (3).

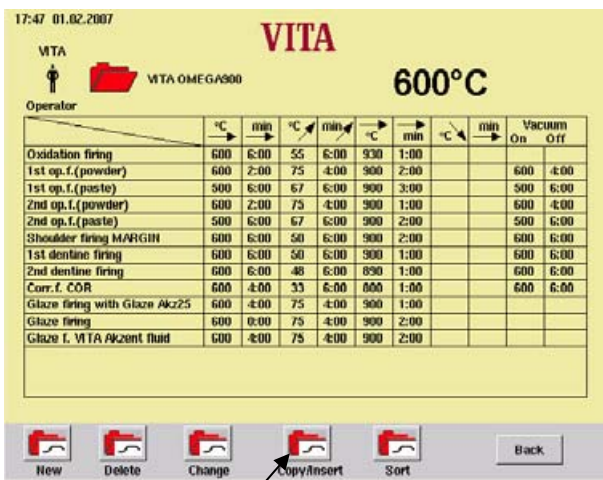

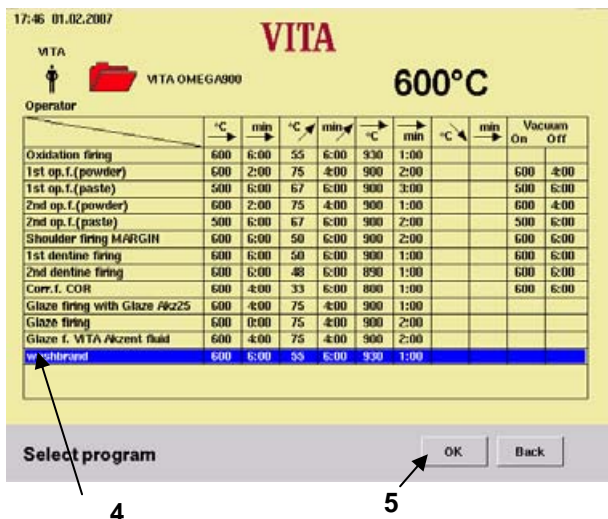

- Select the program (4).
- Press button "OK" (5).

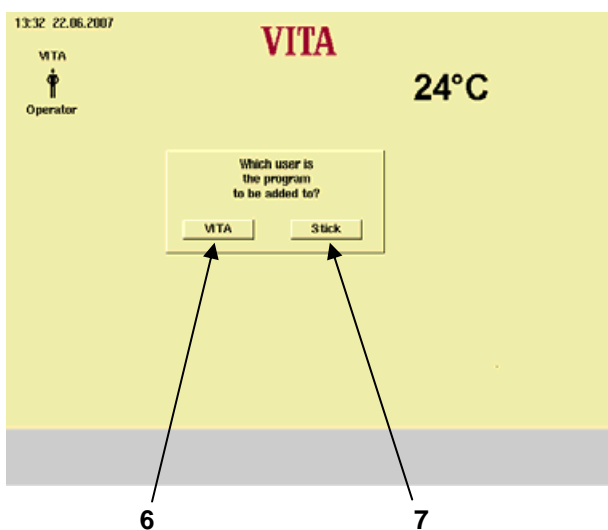

- Press button "Yes" (6) to add the program to the user "Vita".
- or
- Press button "No" (7) to add the program to the user "Stick".

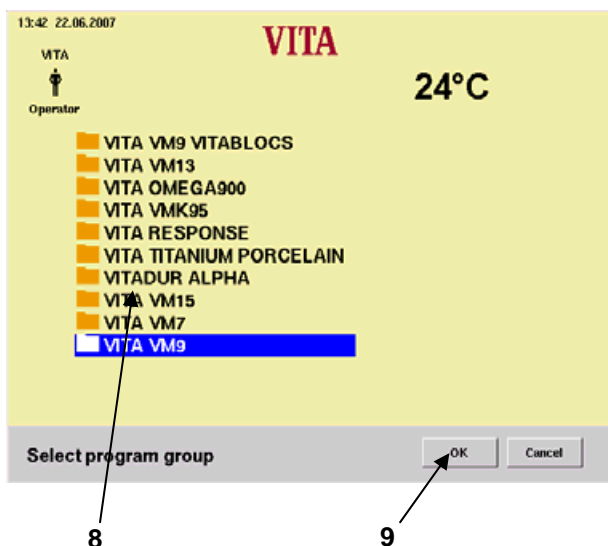

- Select the program group (8), e.g. "Vita VM 7".
- Press button "OK" (9).

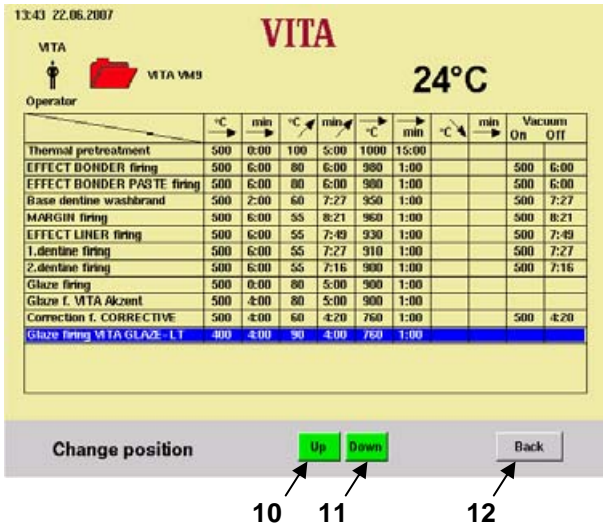

Sort with buttons "Up" (10) or "Down" (11).

- Press button "Back" (12).

- Press button "Back" (12).

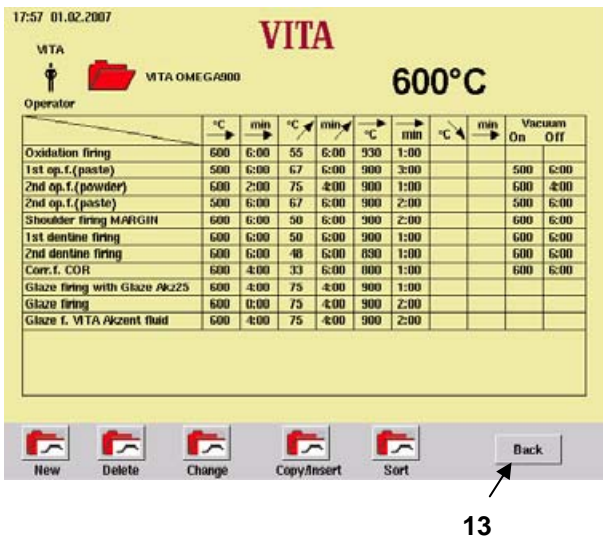

- Press button "Back" 13

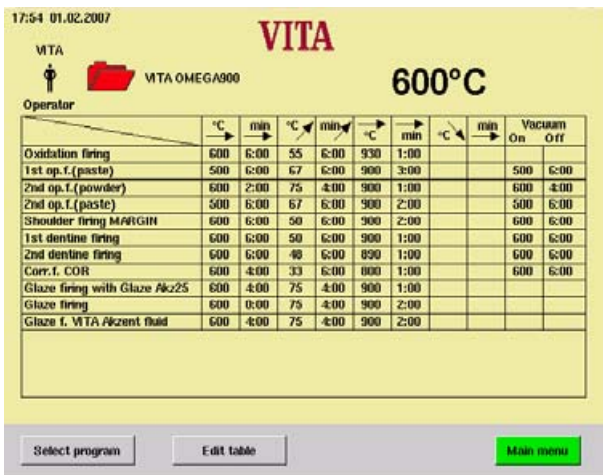

- Press button "Main menu"

23 Service programs

- Press button "Service" in the start menu.

The individual sections are activated by touching with the pin.

Possible changes are saved by actuating the button "Accept".



23.1 Information about the unit/Software

The information field shows technical information about the unit for:

Version cont.	=	Software of control unit
Version core	=	Software for core
Unit – ID cont.	=	Serial-no. of control unit
Unit – ID core	=	Serial-no. of core
VITA	=	Hotline phone-no.
Dealer	=	VITA

Concerning the button "Update" see section 24 "Software Update".

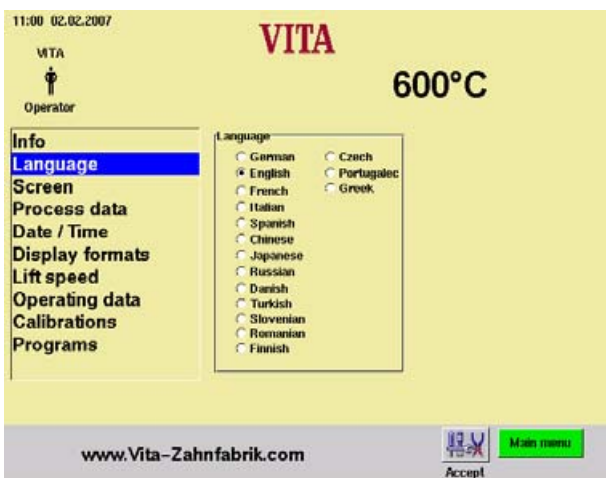

23.2 Language selection

- Select the desired language
- Press button "Accept".
- Press button "Main menu".

i The actual screen display may vary from the opposite illustration.

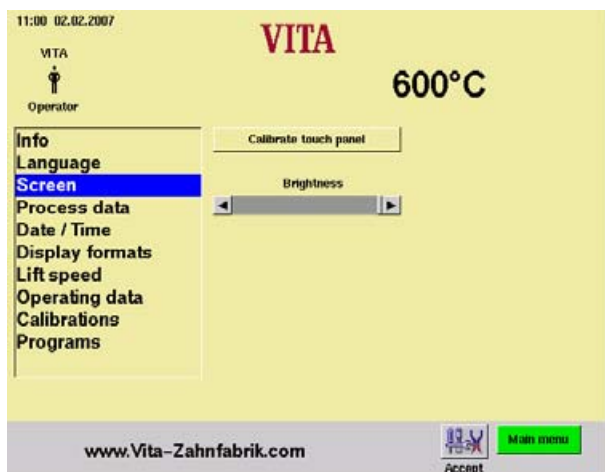

23.4 Screen settings

Calibrating the touch panel

This calibration must be carried out when actuation of a field on the screen does not trigger any action of the desired function.

- Press button "Calibrate Touch-Panel".
- Keep on pressing the dots appearing on the dark display, until the display lights up.

Contrast

- Adjust the desired contrast with the slide switch.
- Press button "Accept".

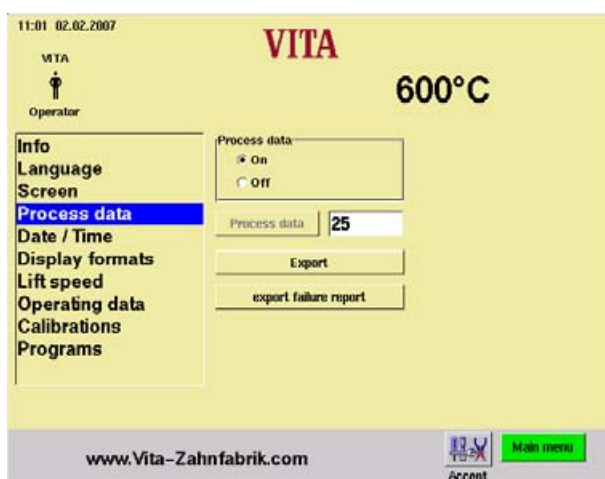

23.5 Process data

see also section 4.

"On" = Process data are saved in the control unit.

"Off" = Process data will not be saved.

"Process data" = Number of saved firing programs.

"Export" = Copies firing data to the Memory Stick.

23.3 Export failure report

Generally, the previous 10 firing programs that have been run are saved.

If an unsatisfactory firing result is obtained or failure has occurred in the program sequence, the failure report can be exported on a memory stick and emailed to instruments-service@vita-zahnfabrik.com for analysis.

An immediate analysis of the failure report is carried out and sent back to the customer.

23.6 Loading firing programs from the Memory Stick

Saved firing programs are exported to the Memory Stick (see also section 4 and).

- Plug in the Memory Stick in the main menu.
- Press button "Service".
- Press button "Process data".
- Press button "Export"

Firing data are transferred to the Memory Stick

After the transfer change to the and pull out the stick.



23.7 Date/Time

- Actuate "Date/Time".

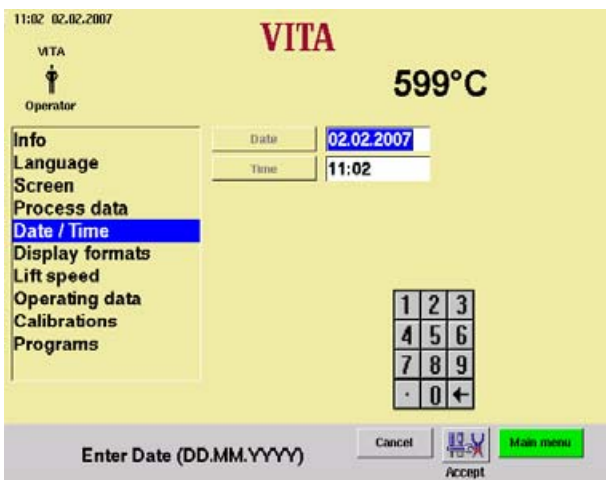

- Press field "Date" or "Time".
- Input date = DD: MM: YY
 Input time = HH: MM
 see also section "Display formats".
- Press button "Accept".

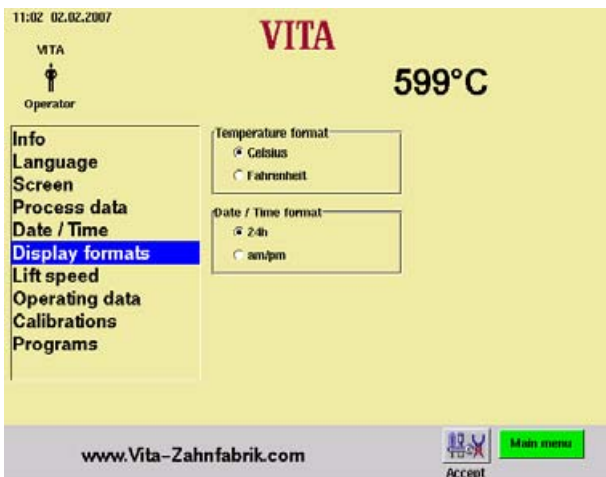

23.8 Display formats

Adjustment for temperature display:

Temperature display in °C

or

Temperature display in °F

Setting Date/Time:

24 h or am/pm

- actuate the desired option.
- Press button "Accept".



23.9 Lift speed settings

Adjust the lift speed with the slide control.

- Operate the slide control.
- Press button "Accept".

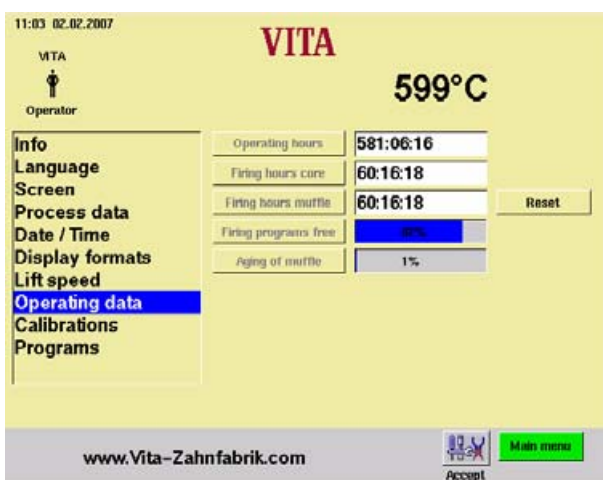

23.10 Operating data

Operating hours:
Total time of unit

Firing hours of heating:
Total firing time

Firing hours of heating:
Firing hours of firing muffle

Firing programs free:
Display in %, related to a maximum of 500 programs.

Degree of aging of firing muffle:
Display in %, related to 4000 firing hours.

23.11 Temperature calibration by means of silver test

With this program and the VITA – Silver Text Set (VITA – Order-No. B 230) the temperature in the firing chamber can be checked and readjusted within the range of plus/minus 20 °C. When adjusting make sure that the instructions for the performance (instructions in the silver test set) of the test with the silver sample are strictly applied. Negligence will cause measuring faults and therefore incorrect adjustments.

There is a default program available for the adjustment of the firing chamber temperature.

For testing the firing chamber temperature by means of the silver sample 2 program runs are required. The first program run must be performed at 955 °C (preset in the program), the silver should not have been fused.

The second program run must be performed at 965 °C, this temperature value must be entered.

After this program run the silver must have been fused ball.

Deviations within the range of plus/minus 20 °C can be entered.



Input "Global temperature offset":

- Actuate the field "°C", the keypad is displayed.
- Enter the value.
- Press button "Accept".



Example:

temperature about 15°C to high

=> insert +15°C

temperature about 15°C to low

=> insert -15°C

Vacuum calibration, see also section 23.12 .

- Press button "Vacuum calibration".
The lift is retracted, the pump switched on, the display shows the vacuum value.

23.12 Vacuum calibration



Before starting make sure that the vacuum pump works with full power and that the vacuum system (seals) in the firing unit is in good conditions.

A too low vacuum caused by leaks in the system **cannot** be compensated with this program.

- Check the power of the vacuum pump with a vacuum tester, independently from the firing unit.

The vacuum system of the firing unit can be checked as follows:

- Start program with vacuum.
- Once the max. vacuum value is reached (display does not rise any further), pull the mains connection for the pump off the firing unit.

The vacuum display does not drop:

- Perform vacuum calibration.

The vacuum display drops:

- Check seals in firing unit.
Quick dropping of the vacuum display indicates a leak in the vacuum system, the full vacuum value is not reached.



Perform vacuum calibration

- Press button "Vacuum calibration".
The vacuum pump starts, the field for vacuum value is displayed, once the maximum vacuum value is reached the pump switches off and the lift moves to bottom position.
- Press button "Accept".

23.13 Programs Cancel

"Press Stop button"

"Without confirmation" = Abort program without confirmation.

"With confirmation" = Abort program with confirmation.

- Choose "Without confirmation" or "With confirmation".
- Press button "Accept".

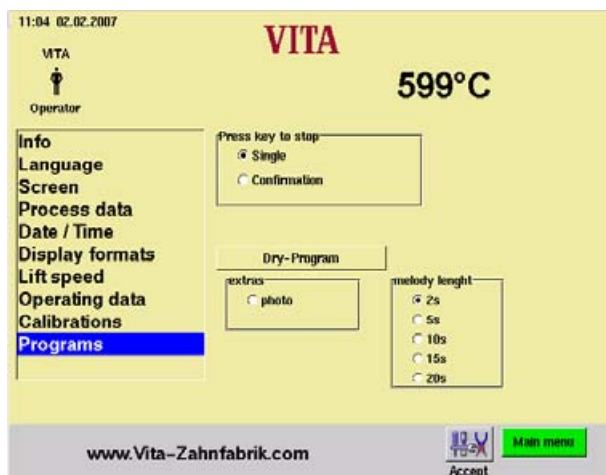

23.14 Melody for end of program

- Select desired length.
- Press Accept button.

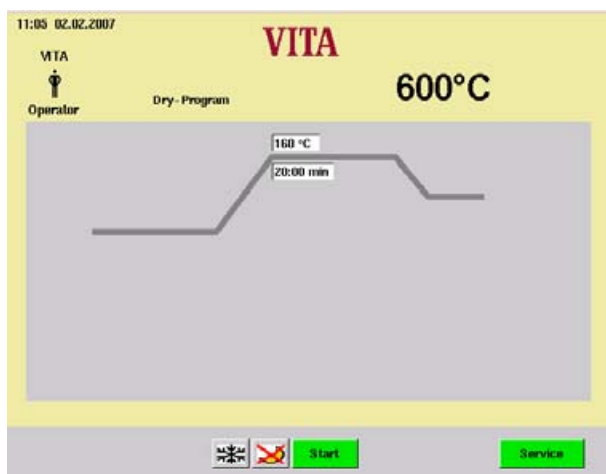

23.15 Dry – Program (Vita In-Ceram sprint)

Temperature area 130°C – 700 °C

Holding time for end tem perature 0-60:00Min

24 Software Update

Software updates are loaded from the Memory Stick into the control unit.

The opposite directory must be created on the Memory Stick. The name of the storage medium may be different.



i Observe the use of small initial letters.

The software update is copied into the directory "Update".

Transfer the update into the control unit as follows:

- Switch off the unit by the main switch.
- Plug in the Memory Stick.
- Switch on the unit by the main switch.
- Press button "Service".
- Press button "Info".
- Press button "Update", the software is transferred.
- Press button "OK" after the end of the transfer.



25 Factory settings

With "Factory Settings" the following functions are reset to factory settings:

Firing programs acc. to VITA firing table, see section 26.

Brightness / contrast, see section 23.4

Language German, see section 23.2

Time format to DD:MM:YY, see section 23.7

Stop single push button contact, see section 23.13

Process data off, see section 23.5

Temperature display °C, see section 23.8

i All programs deviating from the VITA table are thereby deleted.

If some programs are to be maintained, these must be transferred to the Memory Stick beforehand, see section 22.3



26 Firing Tables

26.1 VITA VM 7

	Pre-drying	→ min.	↗ min.	↗ °C/min	Temp. approx. °C	→ min.	VAC min.
BASE DENTINE Wash firing *	500	2.00	7.30	60	950	1.00	7.30
MARGIN firing	500	6.00	7.40	60	960	1.00	7.40
VITAVM 7 EFFECT LINER firing	500	6.00	7.38	55	920	1.00	7.38
1 st dentine firing	500	6.00	7.27	55	910	1.00	7.27
2 nd dentine firing	500	6.00	7.16	55	900	1.00	7.16
Fixing firing of stains	500	6.00	3.00	100	800	-	-
Glaze firing	500	-	5.00	80	900	1.00	-
Glaze firing VITA Akzent Fluid	500	4.00	5.00	80	900	1.00	-
Glaze firing VITA Akzent GLAZE	500	4.00	5.00	80	900	1.00	-
Corrective firing with VITAVM 7 CORRECTIVE	500	4.00	6.00	55	830	1.00	6.00

* Only for VITA In-Ceram AL for inLab

26.2 VITA VM 9

	Pre-drying	→ min.	↗ min.	↗ °C/min	Temp. approx. °C	→ min.	VAC min.
Thermal pretreatment	500	-	5.00	100	1000	15.00	-
EFFECT BONDER firing	500	6.00	6.00	80	980	1.00	6.00
EFFECT BONDER PASTE firing	500	6.00	6.00	80	980	2.00	6.00
Base dentine washbrand	500	2.00	7.27	60	950	1.00	7.27
MARGIN firing	500	6.00	8.21	55	960	1.00	8.21
EFFECT LINER firing	500	6.00	7.49	55	930	1.00	7.49
1. dentine firing	500	6.00	7.27	55	910	1.00	7.27
2. dentine firing	500	6.00	7.16	55	900	1.00	7.16
Glaze firing	500	-	5.00	80	900	1.00	-
Glaze firing with VITA Akzent	500	4.00	5.00	80	900	1.00	-
Correction firing with CORRECTIVE	500	4.00	4.20	60	760	1.00	4.20

* For non-shaded VITA In-Ceram YZ please carry out an EFFECT BONDER firing.

ATTENTION: Do not carry out this firing in the case of shaded VITA In-Ceram YZ !

** For shaded VITA In-Ceram YZ please carry out a BASE DENTINE Wash firing.

ATTENTION: Do not carry out this firing in the case of non-shaded VITA In-Ceram YZ !

26.3 VITAVM®9 for VITABLOCS®

	Pre-drying	→ min.	↗ min.	↗ °C/min	Temp. approx. °C	→ min.	VAC min.
Stains-fixation VITA SHADING PASTE	500	4.00	5.00	76	880	0.30	0.00
1. firing	500	6.00	7.27	55	910	1.00	7.27
2. firing	500	6.00	7.16	55	900	1.00	7.16
Glaze firing VITA SHADING PASTE "glaze"	500	4.00	5.00	80	900	1.00	0.00
Glaze firing VITA Akzent finishing agent	500	4.00	5.00	80	900	1.00	0.00
Corrective firing CORRECTIVE	500	4.00	4.20	60	760	1.00	4.20

26.4 VITA VM 13

	Pre-drying	→ min.	↗ min.	↗ °C/min	Temp. approx. °C	→ min.	VAC min.
Oxydation firing	Follow manufacturer instructions !						
WASH OPAQUE firing	500	2.00	5.12	75	890	2.00	5.12
WASH OPAQUE PASTE firing	500	2.00	5.12	75	890	2.00	5.12
OPAQUE firing	500	2.00	5.12	75	890	1.00	5.12
OPAQUE PASTE firing	500	4.00	5.12	75	890	1.00	5.12
MARGIN firing	500	6.00	7.05	55	890	2.00	7.05
EFFECT LINER firing	500	6.00	7.05	55	890	1.00	7.05
1. dentine firing	500	6.00	6.55	55	880	1.00	6.55
2. dentine firing	500	6.00	6.44	55	870	1.00	6.44
Glaze firing	500	-	4.45	80	880	2.00	-
Glaze firing with VITA Akzent	500	4.00	4.45	80	880	1.00	-
Correction firing witCORRECTIVE	500	4.00	6.00	60	800	1.00	6.00

When using dental ceramics, the firing result largely depends on the individual firing procedure of the user, i.e. among other aspects on the type of furnace, the location of the temperature sensor, the firing tray as well as the size of the workpiece during the firing cycles.

Our application-technical recommendations (regardless whether they have been provided orally, in writing or in the form of practical instructions) are based on numerous own experiences and tests. The user, however, should consider this information only to provide basic values. If surface, transparency and degree of gloss should not correspond to the firing result that is achieved under optimal conditions, the firing procedure must be adjusted correspondingly. The crucial factors for the firing procedure are not the firing temperature displayed by the furnace but the appearance and the surface condition of the firing object after the firing process.

26.5 VITA VM®15

	Pre-drying	→ min.	↗ min.	↗ °C/min	Temp. approx. °C	→ min.	VAC min.
Oxidation firing	Follow manufacturer instructions !						
WASH OPAQUE firing	400	2.00	6.00	70	820	1.00	6.00
WASH OPAQUE PASTE firing	400	6.00	6.00	70	820	1.00	6.00
OPAQUE firing	400	2.00	6.00	70	820	1.00	6.00
OPAQUE PASTE firing	400	6.00	6.00	70	820	1.00	6.00
MARGIN firing	400	6.00	8.12	50	810	1.00	8.12
EFFECT LINER firing	400	6.00	8.12	50	810	1.00	8.12
1. dentine firing	400	6.00	8.00	50	800	1.00	8.00
2. dentine firing	400	6.00	7.48	50	790	1.00	7.48
Glaze firing	400	0.00	4.52	80	790	1.00	-
Glaze firing VITA Akzent	400	4.00	4.52	80	790	1.00	-
Glaze firing VITA Glaze LT	400	4.00	4.45	80	780	1.00	-
Correction firing with CORRECTIVE	400	4.00	7.00	50	750	1.00	7.00

26.6 VITA VMK 95

	Pre-drying	→ min.	↗ min.	↗ °C/min	Temp. approx. °C	→ min.	VAC min.
Oxidation firing	Follow manufacturer's instructions !						
1 st opaque firing (powder)	600	2.00	4.00	88	950	1.00	4.00
1 st opaque firing (paste)	500	6.00	6.00	75	950	1.00	6.00
2 nd opaque firing (powder)	600	2.00	4.00	83	930	1.00	4.00
2 nd opaque firing (paste)	500	6.00	6.00	72	930	1.00	6.00
Margin porcelain firing "MARGIN"	600	6.00	6.00	55	930	1.00	6.00
1 st dentine firing	600	6.00	6.00	55	930	1.00	6.00
2 nd dentine firing	600	6.00	6.00	55	930	1.00	6.00
3 rd dentine firing	600	6.00	6.00	53	920	1.00	6.00
Correction porcelain firing withCOR	600	4.00	6.00	50	900	1.00	-
Glaze firing	600	-	4.00	83	930	1.00	-
Glaze firing with VITA Akzent® Fluid	600	4.00	4.00	83	930	1.00	-
Glaze firing with Glaze Akz25	600	4.00	4.00	75	900	1.00	-

26.7 VITA OMEGA 900

	Pre-drying	→ min.	↗ min.	↗ °C/min	Temp. approx. °C	→ min.	VAC min.
Oxidation firing	Follow manufacturer's instructions !						
1 st opaque firing (powder)	600	2.00	4.00	75	900	2.00	4.00
1 st opaque firing (paste)	500	6.00	6.00	67	900	3.00	6.00
2 nd opaque firing (powder)	600	2.00	4.00	75	900	1.00	4.00
2 nd opaque firing (paste)	500	6.00	6.00	67	900	2.00	6.00
Margin porcelain firing "MARGIN"	600	6.00	6.00	50	900	2.00	6.00
1 st dentine firing	600	6.00	6.00	50	900	1.00	6.00
2 nd dentine firing	600	6.00	6.00	48	890	1.00	6.00
Correction porcelain firing with COR	600	4.00	6.00	33	800	1.00	6.00
Glaze firing	600	---	4.00	75	900	2.00	---
Glaze firing with VITA Akzent® Fluid	600	4.00	4.00	75	900	2.00	---
Glaze firing with Glaze Akz25	600	4.00	4.00	75	900	1.00	---

26.8 VITA TITANIUM PORCELAIN

	Pre-drying	→ min.	↗ min.	↗ °C/min	Temp. approx. °C	→ min.	VAC min.
Paste bonder firing	400	6.00	6.00	67	800	1.00	6.00
Powder bonder firing	400	2.00	6.00	67	800	1.00	6.00
Opaque firing	400	2.00	4.00	98	790	1.00	5.00
Shoulder firing	400	6.00	7.00	53	770	1.00	8.00
1 st dentine firing	400	6.00	7.00	53	770	1.00	8.00
2 nd dentine firing	400	6.00	7.00	53	770	1.00	8.00
Glaze firing without glaze	400	-	4.00	93	770	1.00	5.00
Stains firing*	400	4.00	3.00	100	700	1.00	-
Glaze firing with Akzent glaze Akz25	400	4.00	4.00	93	770	1.00	5.00

26.9 VITADUR® ALPHA

	Pre-drying	→ min.	↗ min.	↗ °C/min	Temp. approx. °C	→ min.	VAC min.
Stains firing	600	6.00	3.00	67	800	---	---
1 st Dentine firing	600	6.00	6.00	60	960	1.00	6.00
2 nd Dentine firing	600	6.00	6.00	58	950	1.00	6.00
Glaze firing	600	---	4.00	85	940	1.00	---
Glaze firing with VITA Akzent Fluid	600	4.00	3.00	113	940	1.00	---
Glaze firing without glaze	600	4.00	3.00	107	920	1.00	---

26.10 Soldering in VITA VACUMAT® 4000 Premium T

Method 1

Preheat the objects in the muffle preheating oven with solder flux and soldering balls for 15-20 minutes at 400 °C.

Program 93

The working temperature of the respective soldering agent + 50°C is the final temperature.

Pre-drying: 5.00 min.

Heating: 5.00 min.

Holding: 3.00 min.

Method 2

Preheat the objects in the muffle preheating oven, but without applied soldering agent for 15-20 minutes at 400 °C.

Program 94

The working temperature of the respective soldering agent + 50°C is the final temperature.

Pre-drying: 1.00 min.

Heating: 3.00 min.

Holding: 4.00 min

27 Error messages

Message in display	Detection	Test/remedy
<p style="text-align: center;">Error! Vacuum was not reached. Please confirm with OK.</p> <p style="text-align: center;">OK</p>	<p>If a value of at least 30 % is not reached within 30 seconds, the program is aborted.</p>	<ul style="list-style-type: none"> • Check/clean/replace the lift plate seal • Clean the sealing edge on the firing chamber floor. Cleaning work see section 8.3 • Check vacuum pump independently from unit. • Check vacuum system of firing unit. • see also section 23.12 • Perform vacuum calibration. see also section 23.12
<p style="text-align: center;">Warning! Vacuum measurement not calibrated. Please confirm with OK Execute calibration in menu 'Service- > Vacuum'.</p> <p style="text-align: center;">OK</p>	<p>Information in display</p>	<ul style="list-style-type: none"> • Perform vacuum calibration. see also section 23.12 •
<p style="text-align: center;">Error! The fan does not work correctly. Consult a service station. Please confirm with OK.</p> <p style="text-align: center;">OK</p>	<p>The running firing program is terminated.</p>	<ul style="list-style-type: none"> • Check fan connection X7 on printed circuit board. • Clean/replace fan.
<p style="text-align: center;">Error! The lift is blocked. Remove blockade.</p> <p style="text-align: center;">OK</p>	<p>The lift moves too far down</p>	<ul style="list-style-type: none"> • Limit switch for bottom position does not work. Check limit switch connection X 8 on printed circuit board, the associated LED must light when the limit switch is operated. • Check/adjust/replace the limit switch.
<p style="text-align: center;">Error! Temperature in firing chamber higher than 1200°C/2192°F! Consult a service station. Please confirm with OK.</p> <p style="text-align: center;">OK</p>	<p>The display shows a reading of more than 1200°C</p>	<ul style="list-style-type: none"> • This fault can have several different reasons, detection/rectification of this fault requires expert knowledge and the use of technical measuring equipment. • Replace the CPU – board.

Message in display	Detection	Test/remedy
<p style="text-align: center;">Error! Temperature sensor 1 defective. Consult a service station. Please confirm with OK.</p> <p style="text-align: center;">OK</p>	<p>Program is aborted</p>	<ul style="list-style-type: none"> • Check connection of thermo element X 20 on the printed circuit board. • Check the connection of the thermo element on the firing chamber. • Check the connection of the thermo element in the firing chamber. • Check thermo elements – replace thermo element
<p style="text-align: center;">Error! Temperature sensor 2 defective. Consult a service station. Please confirm with OK.</p> <p style="text-align: center;">OK</p>	<p>Program is aborted</p>	<ul style="list-style-type: none"> • Check connection of thermo element X 22 on the printed circuit board. • Check the connection of the thermo element on the firing chamber. • Check the connection of the thermo element in the firing chamber. • Check thermo element – replace thermo element.
<p style="text-align: center;">Warning! The battery is empty.</p> <p style="text-align: center;">OK</p>	<p>Information in display</p>	<p>Replace the battery on the CPU - board</p>
<p style="text-align: center;">Error! The nominal firing compartment temperature was exceeded for more than 5:00 Check whether a heating change is required. Please confirm with OK.</p> <p style="text-align: center;">OK</p>	<p>Temperature rise does not comply with the specified time.</p>	<p>Heating defective Heating too slow Triac defective Triac control defective</p>
<p style="text-align: center;">Error! The temperature control caused an error. Check whether a heating change is required or consult a service station. Please confirm with OK.</p> <p style="text-align: center;">OK</p>	<p>No temperature rise</p>	<p>Old heating or Triac</p>
<p style="text-align: center;">Error! Heating is not addressed! Switch of the unit and consult a service station. Please confirm with OK.</p> <p style="text-align: center;">OK</p>	<p>Information in display</p>	<p>Check connecting cable furnace – control. – Replace connecting cable</p> <p>Check connecting plug for control. – Replace the control.</p> <p>Check connecting plug for furnace – Replace connecting plug</p>

Message in display	Detection	Test/remedy
Permanent sound of approx. 6 seconds	Permanent sound	Fuse defective, see section 8.5 Replace defective fuse Check heater connection on circuit board Replace CPU – circuit board

A

Adjustment of standby temperature · 22
 Alphanumerical input · 20
 Automatic temperature adjustment · 17

C

CE – Sign · 15
 Change of start temperature · 37
 Changing a program group · 42
 Changing firing programs · 51
 Changing program values · 26
 Changing the lift position cooling · 34
 Changing the pre-drying time · 26, 28
 Changing the user · 18
 Cleaning · 15
 Cleaning the control unit · 15
 Cleaning the unit · 15
 Connecting the unit to the mains supply · 12
 Copying/inserting a program group · 44
 Copying/inserting firing programs · 53
 Copyright · 6
 Creating a user · 18
 Creating program groups · 39

D

Damage of the touchscreen · 19, 21
 Deleting firing programs · 49
 Deleting program groups · 41
 Direct input of changes for lift position and position time · 31
 Display formats · 58
 Disposal · 6
 Dry – Program · 61

E

Electric data · 10
 Error message Vacuum · 38
 Error messages · 68
 Export failure report · 57

F

Fan · 16
 Firing programs · 8
 Foreword · 6
 Format · 58
 Formation of condensation water · 38
 Fuses · 15

G

General description · 7

I

Information about the unit · 56
 Information decals · 14
 Initial start-up of unit · 12
 Input · 19
 Installation and start-up · 11
 Intended use · 13

L

Language selection · 56
 Languages · 8, 56
 Liability · 14, 16
 Lift position and position time in pre-drying menu · 33
 Lift position cooling · 34
 Lift positions · 30
 Lift positions and position times for pre-drying · 30
 Lift positions for cooling · 34
 Lift positions for pre-drying · 31
 Lift speed · 59
 Lift speed settings · 59
 Liftposition im Abkühlmenü · 35

M

Mains voltage failure time · 16
 Melody for end of program · 61
 Memory Stick · 18
 Mounting location · 11

N

Notes on safety · 13
 Numerical input · 19

O

Operating data · 59
 Operation and cleaning of the control unit · 15

P

Pictograms · 6
 Pre-drying · 26, 30
 Pre-drying menu · 33
 Pre-drying phase · 30
 Pre-drying time · 30

Pre-vacuum · 39
 Process data · 57
 Programmwerte ändern im Grafikmodus · 26
 Programmwerte ändern im Tabellenmodus · 28

Q

Quality assurance · 9
 Quickstart · 20
 Quickstarting a firing program · 20

R

Racks · 14

S

Safety functions · 9
 Saving of firing data for quality assurance · 9
 Scope of delivery · 10
 Screen settings · 57
 Selecting a firing program · 24
 Service programs · 8, 56
 Shutting down the unit · 13
 Silver test · 60
 Software · 56
 Software Update · 62
 Soldering in VITA VACUMAT® 40 T · 67
 Sorting program groups · 45
 Spare parts · 16
 Standby · 22
 Start menu · 21
 Start/stop standby mode · 23
 Start-up · 12

T

Tabellenmodus · 28
 Technical data · 10
 Technical information · 7
 Temperature adjustment · 17
 Temperature calibration · 60
 Temperature rise · 17
 Time · 58

U

USB – interface · 18
 User assigned programs · 18

V

Vacuum calibration · 60
 Vacuum display · 38
 Vacuum settings · 37
 Vacuum value · 38
 Vita In-Ceram sprint · 61
 VITA OMEGA 900 · 66
 VITA TITANIUM PORCELAIN · 66
 VITA VM 13 · 64
 VITA VM 7 · 63
 VITA VM 9 · 63
 VITA VMK 95 · 65
 VITADUR® ALPHA · 67
 Voltage failure protection · 16
 Voltage supply failure · 16
 Vortrocknen · 30

W

Warranty · 16

With the unique VITA SYSTEM 3D-MASTER® all natural tooth shades are systematically determined and completely reproduced.

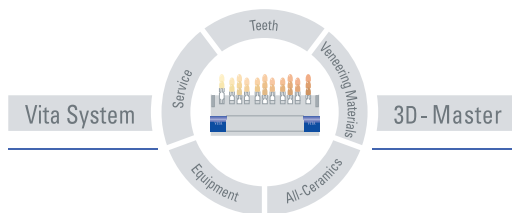

Please note: Our products should be used according to the working instructions. We cannot be held liable for damages resulting from incorrect handling or usage. The user is furthermore obliged to check the product before use with regard to its suitability for the intended area of applications. We cannot accept any liability if the product is used in conjunction with materials and equipment from other manufacturers which are not compatible or not authorized for use with our product. Furthermore, our liability for the correctness of this information is independent of the legal ground and, in as far as legally permissible, is limited to the invoiced value of the goods supplied excluding turnover tax. In particular, as far as legally permissible, we do not assume any liability for profit loss, for indirect damages, for consequential damages or for claims of third parties against the purchaser. Claims for damages based on fault liability (culpa in contrahendo, breach of contract, unlawful acts, etc.) can only be made in the case of intent or gross negligence. Date of issue of these directions for use: 07-07.



VITA

VITA Zahnfabrik H. Rauter GmbH & Co. KG
Postfach 1338 · D-79704 Bad Säckingen / Germany
Tel. +49/(0)7761/562-0 · Fax +49/(0)7761/562-299
Hotline: +49/(0)7761/562-222 · Fax +49/(0)7761/562-446
www.vita-zahnfabrik.com · info@vita-zahnfabrik.com