

# Operating instructions

## K- Control 4960, 4965, 4970.



Always on the safe side.



KaVo. Dental Excellence.

**Vertrieb/distribution:**

**KaVo Dental GmbH**

Bismarckring 39 D-88400 Biberach

Tel.: 0 73 51 / 56-0 • Fax: 0 73 51 / 56 -14 88

**Hersteller/manufacturer:**

**Kaltenbach & Voigt GmbH**

Bismarckring 39

D-88400 Biberach



# K- Control 4960, 4965, 4970.

<b>A 1</b>	<b>User information</b> .....	<b>2</b>
	A 1.1 Meaning of the pictograms .....	2
	A 1.2 Important information .....	2
	A 1.3 Precautions .....	2
	A 1.4 Purpose and potential uses .....	3
	A 1.5 Technical data .....	3
	A 1.6 Combination Controller - handpiece .....	4
<b>A 2</b>	<b>Scope of delivery/Accessories</b> .....	<b>5</b>
<b>A 3</b>	<b>Electrical connection</b> .....	<b>5</b>
<b>A 4</b>	<b>Location</b> .....	<b>6</b>
<b>A 5</b>	<b>Mounting and connection</b> .....	<b>7</b>
	A 5.1 Mounting 4960 .....	7
	A 5.2 Mounting 4965 / 4970 .....	8
	A 5.3 Connection .....	8
<b>A 6</b>	<b>Controls and functional elements</b> .....	<b>9</b>
<b>A 7</b>	<b>Preparations for commencing operation</b> .....	<b>10</b>
<b>A 8</b>	<b>Operation</b> .....	<b>11</b>
	A 8.1 Starting K-Control knee control unit 4960 .....	11
	A 8.2 Starting K-Control Benchtop Control unit 4965. ....	11
	A 8.3 Starting a K-Control installation with the type 4970 Foot control unit. ....	11
<b>A 9</b>	<b>Operating faults</b> .....	<b>12</b>
	Guarantee conditions .....	14
	Spare parts .....	15
	EC- Declaration of conformity .....	18
	Drilling template .....	20

# K- Control 4960, 4965, 4970.

## A 1 User information

### A 1.1 Meaning of the pictograms

 Situations where failure to follow the instructions may lead to danger, damage to material or operating faults.

 Important information for operator and engineer.

 Automatic mode  
Automatic sequence

 Close, screw in,  
fasten, etc.

 Open, release, loosen

+ more, higher

- less, lower

 Continuous operation

 Time, time sequence

 Disconnect mains plug

I Device ON, turned on

O Device OFF, unplug from the power supply

### A 1.2 Important information

 The instructions for use should be read by the user before starting up the unit for the first time, in order to avoid incorrect operation and other damage. If other language versions are required, please request these from your responsible KaVo agent. Duplication and distribution of the instructions for use (IU) require KaVo's prior consent.

All technical data, information and properties of the product described in the IU correspond to the state on going to press.

Modifications and improvements to the product as a result of new technical developments are possible.

This does not imply any right to retrofitting of existing units.

KaVo assumes no responsibility for damage arising through:

- external influences (poor quality of the media or inadequate installation)
- use of incorrect information
- improper use
- improperly performed repairs.

Repair and maintenance work - apart from the activities described in these instructions for use - may be performed only by qualified technical personnel.

In the event of modifications by third parties, the approvals become null and void. KaVo recommends using only original spare parts for operation and for repair.

 Please note that the EC Directive on waste electrical and electronic equipment applies to this product. Within Europe therefore, this product must undergo special disposal. For more detailed information about this, please contact KaVo or your specialist dental supplier.

### A 1.3 Precautions

Safe operation and protection of the unit are ensured only through proper use in accordance with the instructions for use and using the tools approved for the purpose. The following should also be observed:

- the work safety regulations,
- the accident prevention regulations.



■ Each time before switching on, check the set speed.

■ Observe the permissible maximum speed and maximum pressure of the tools (according to tool manufacturer's instructions).

### A 1.4 Purpose and potential uses

K-Control-installation is versatile and very suitable for working on crowns and bridges.

### A 1.5 Technical data

#### Dimensions and weight

K-Control Knee-Operated Control Unit  
type 4960

Width:	95 mm
Depth:	280 mm
Height:	235 mm
Weight:	approx.3 kg

K-Control Benchtop Control Unit  
type 4965

Width:	95 mm
Depth:	280 mm
Height:	235 mm
Weight:	approx. 3 kg

K-Control Foot Control Unit  
type 4960

Width:	245 mm
Depth:	275 mm
Height:	125 mm
Weight:	approx.3 kg

#### Rated voltage

Line voltage fluctuations	< ± 10 %
Voltage range:	100 / 120 / 230 V 50 / 60 Hz

#### Rated power

K-Control units	max.220 W
-----------------	-----------



# K- Control 4960, 4965, 4970.

## A 1.6 Combination Controller - hand-piece

In the combination with K-Control control units of types 4960, 4965 and 4970, the following handpieces can be operated:

K 5 Handpiece	4910
K 9 Handpiece	950/955
K 9 Handpiece	4930
K 9 Compact motor	970
K 9 Cutter spindle	960
K 10 Handpiece	4950
(with Adapter 0.674.4721)	
K 11 Handpiece	4990
K 12 Handpiece	4940
SF Handpiece	4005
(with supply cable 0.674.4921)	
K-POWERgrip	4941
K-ERGOgrip	4944

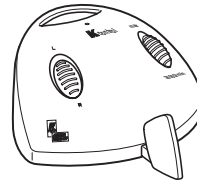
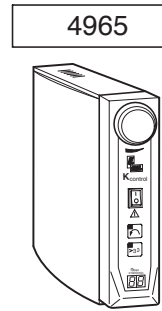
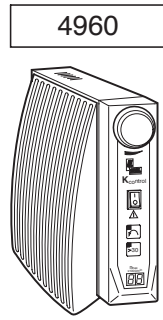

4970

**⚠** The safety of the K-Control control units with handpieces can be guaranteed only with the handpiece/control unit combinations approved by KaVo.

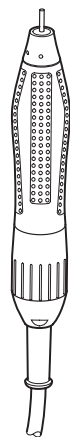

K-POWERgrip K12



K5



K11



K9



SF

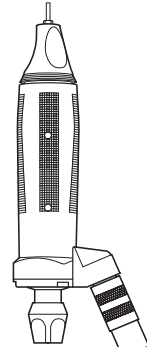

K-ERGOgrip



# K- Control 4960, 4965, 4970.

## A 2 Scope of delivery/Accessories

K-Control Knee-operated control unit 4960

4960

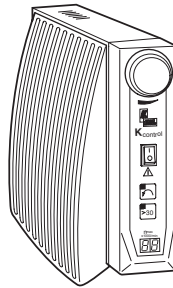

or

K-Control Benchtop, control unit 4965

4965

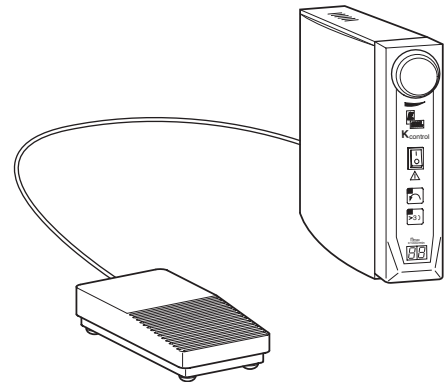

optional

Foot switch 4620

Mat.-No. 0.223.2085

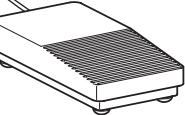

4620

or

K-Control Foot control unit 4970

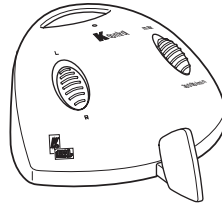

4970

## A 3 Electrical connection

### Electrical connection

Check that the local mains voltage and mains frequency coincide with the specifications on the rating plate and the fuse holder ①. Adapt if required.

### Voltage adaptation to 100 V/120 V or 230 V.

By removing the fuse holder ①, the sleeve ② with contacts (including fuses) can be removed. The adaptation is achieved by appropriately rotating the sleeve ② until the required voltage, 100 V/120 V or 230 V, appears in the inspection window of fuse holder ①.

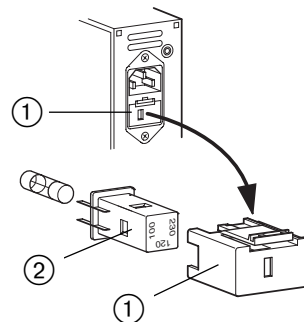

### Connected load.

Nominal power max. 220 W.

### Disconnection:

Use mains plug as disconnection.

# K- Control 4960, 4965, 4970.

## A 4 Location

The K-Control Knee control unit, type 4960, is made to be attached to the side of a storage cabinet (**A 5.1**).

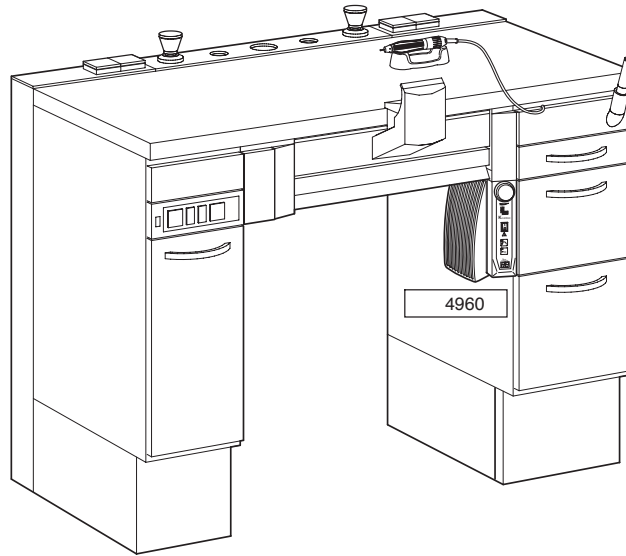

The K-Control Benchtop control unit, type 4965, is made to be set on a workbench and connected underbench with Foot switch type 4620 (**A 5.2**).

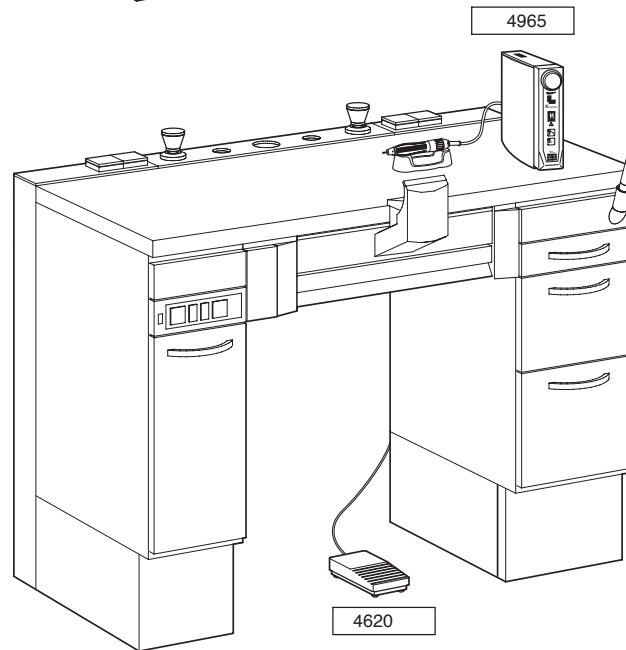

The K-Control Foot control unit, type 4970, can be set unsecured on the floor (**A 5.2**).

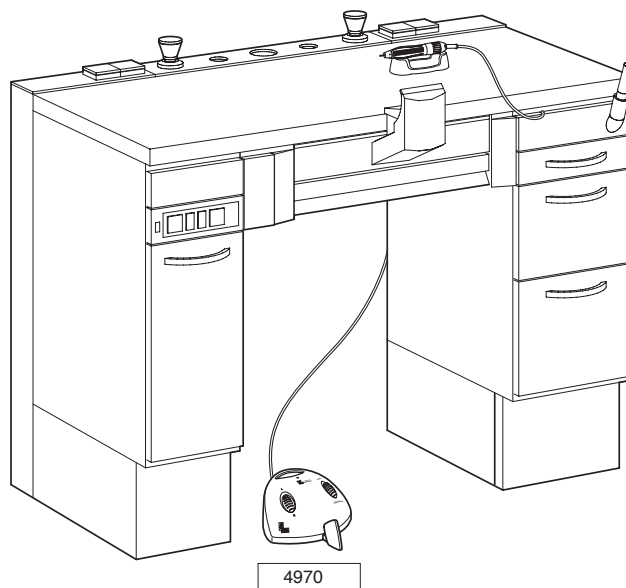



# K- Control 4960, 4965, 4970.

## A 5 Mounting and connection

### A 5.1 Mounting 4960

The K-Control Knee control unit, type 4960, is made to be fastened to the side of a storage cabinet on a suspension rail ① (drilling template see page 20).

**!** Fix in place at the front with screws and insert mains plug into a grounded mains socket which is easy to reach. (Similarly if using an extension line)

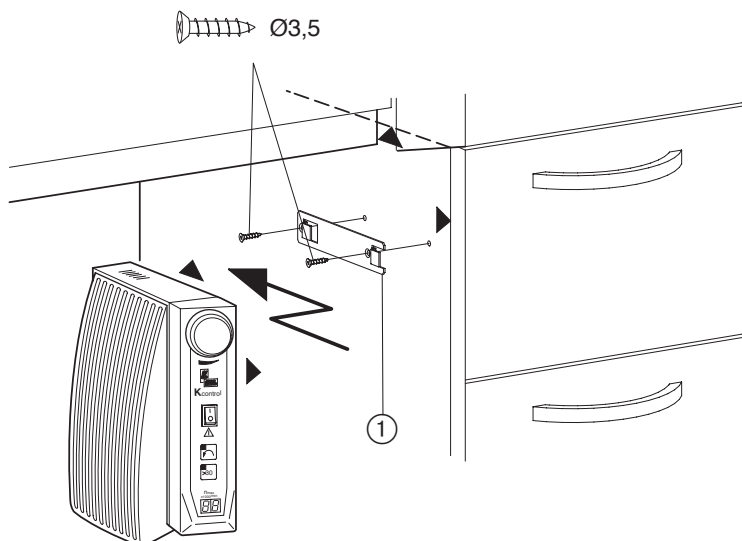
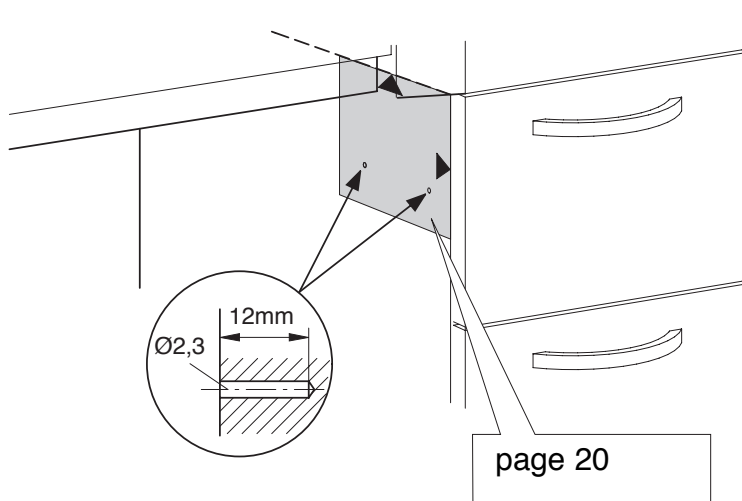

## Demounting

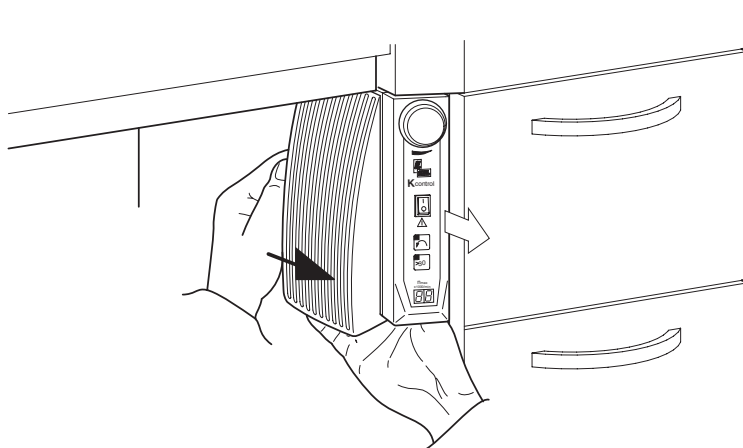

# K- Control 4960, 4965, 4970.

## A 5.2 Mounting 4965 / 4970

Set K-Control Benchtop control unit, type 4965 on a workbench

Set K-Control Foot control unit, type 4970, on the floor under a workbench.

**⚠** Fix in place at the front with screw and insert mains plug into a grounded mains socket which is easy to reach. (Similarly if using an extension line)

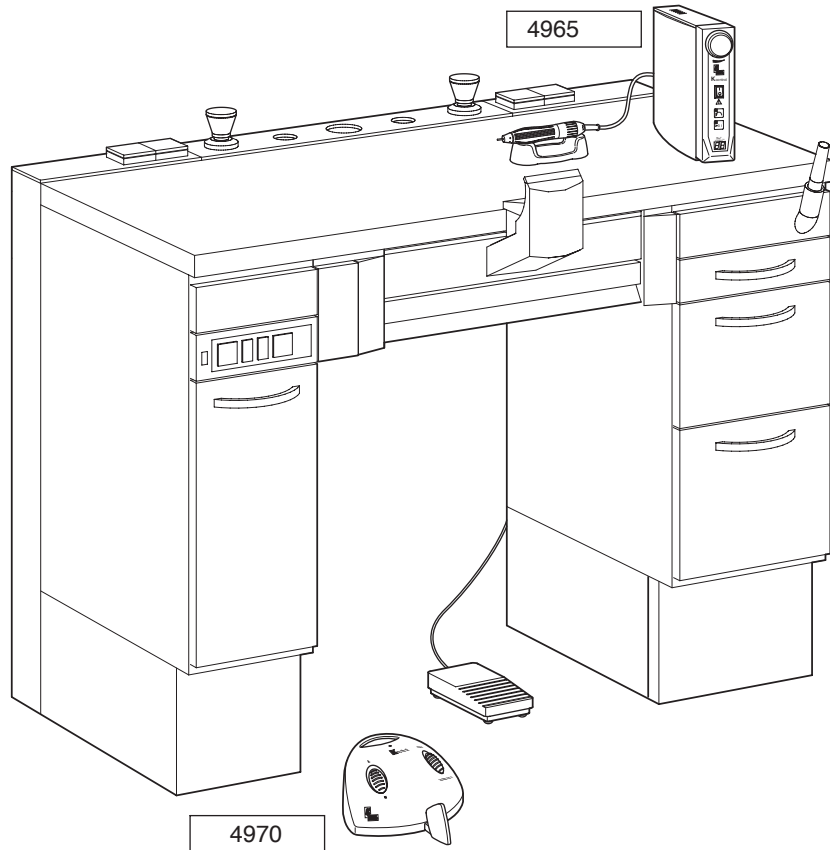

## A 5.3 Connection

Plug in Handpiece and foot switch and screw finger tight.

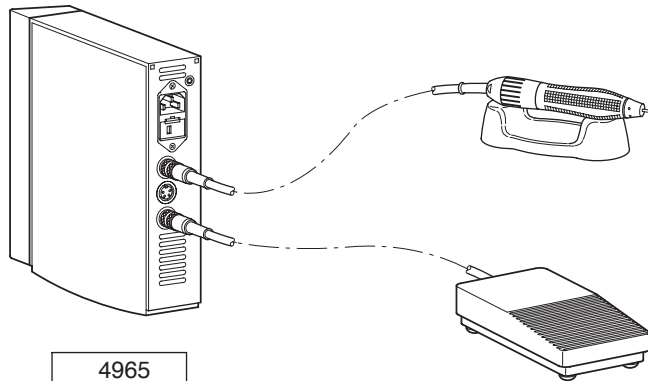

Plug in Handpiece and screw finger tight.

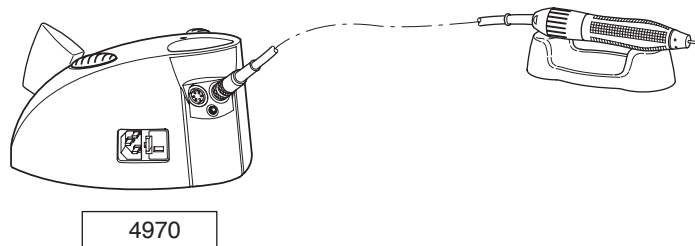

# K- Control 4960, 4965, 4970.

## A 6 Controls and functional elements

① Digital speed and malfunction indicator

② Speed limitation preselector

③ Direction switch (counterclockwise running limited to max. 5000 min<sup>-1</sup>)

④ Mains switch "0"/"1"

⑤ Knee switch

⑥ Speed preselector (continuous)

⑦ Suspension rail

⑧ Fuse holder with voltage adjustment

⑨ Motor sockets (4-pole)

⑩ Starter socket (5-pole)  
(Foot switch)

⑪ Foot switch Type 4620

⑫ Foot lever

⑬ Control cable jack (connection to the dust extractor)

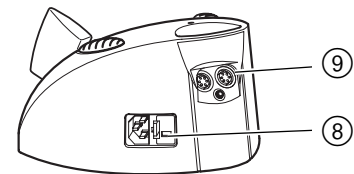
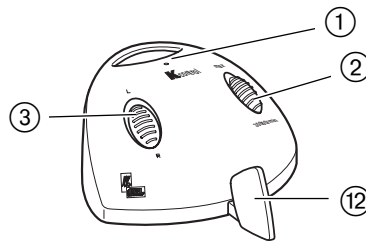
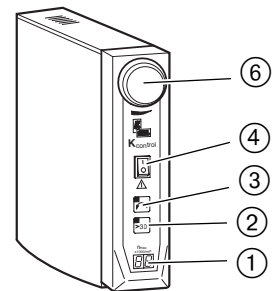
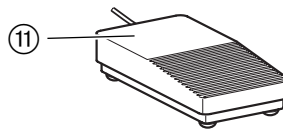
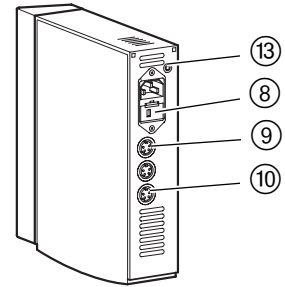
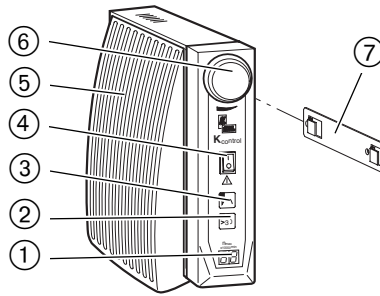

# K- Control 4960, 4965, 4970.

## A 7 Preparations for commencing operation

On K-Control control units 4960 and 4965, push mains switch ④ to the "0" OFF position.

Switch the K-Control Foot control unit, type 4970, to "0" OFF by letting back the foot lever. Set sliding switch ② or button ② for speed limitation to "max. 30,000 min<sup>-1</sup>".

Set direction switch ③ to "clockwise" (yellow LED does not light up) or "R". For "counterclockwise", the handpiece speed is limited to about 5000 min<sup>-1</sup>.

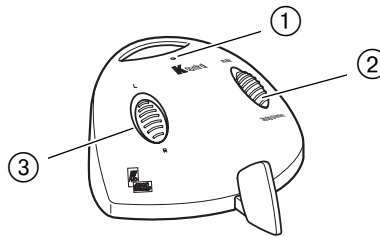
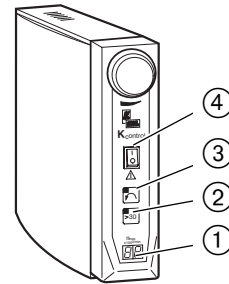
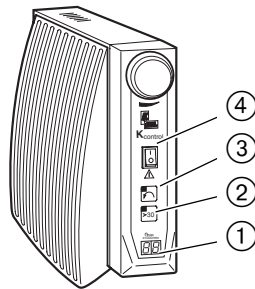

**⚠** Do not operate or lay down your Motorhandpiece, unless an instrument or the test pin is clamped in the chuck. When the chuck is open, Handpiece is locked, and inadvertent use will cause the K-Control control unit to switch to malfunction. Malfunction indicator ① lights up or begins to flash.

# K- Control 4960, 4965, 4970.

## A 8 Operation

 Check set speed each time before switching on.

Regulations for prevention of accidents are to be observed!

When preselecting a speed over 30,000 min<sup>-1</sup>, button ② should be pressed (yellow LED lights up). This additional “enabling” serves for consciously registering the high speed and the resultant possible danger when using tools which may be unsuitable.

### A 8.1 Starting K-Control knee control unit 4960

Preselect desired maximum speed on speed limiter ②.

When the knee switch plate is pressed in the direction of the arrow the speed can be continuously regulated from 1000 min<sup>-1</sup> to the preselected maximum speed.

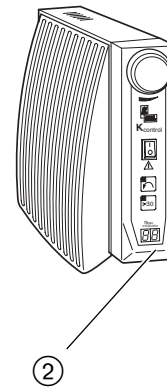
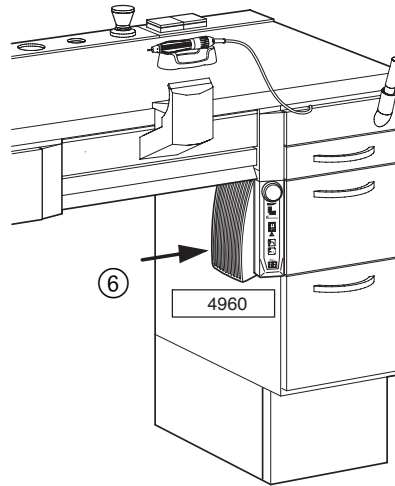

### A 8.2 Starting K-Control Benchtop Control unit 4965.

Preselect desired maximum speed on speed limiter ②.

Start your Handpiece at the preselected speed by depressing Foot switch 4620 ⑪.

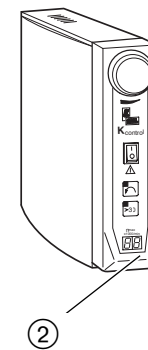
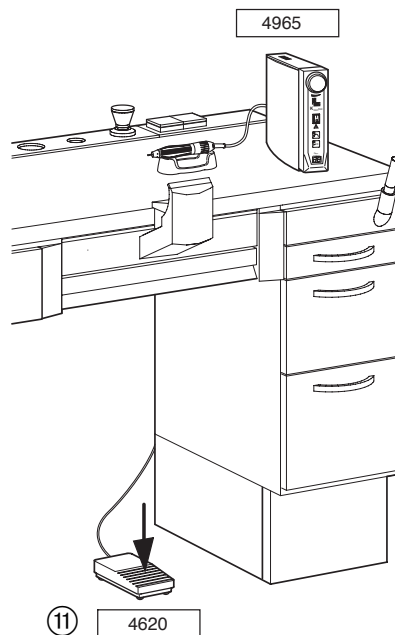

### A 8.3 Starting a K-Control installation with the type 4970 Foot control unit.

By pressing the foot control lever in the direction of the arrow, the speed of the Handpiece can be regulated (enabled by sliding switch ②).

Allowing the foot lever ⑧ to return under spring pressure all the way back, stops the Handpiece.

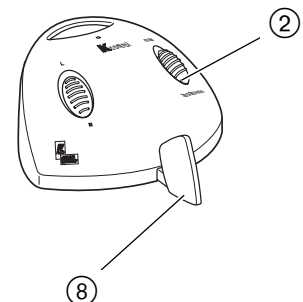
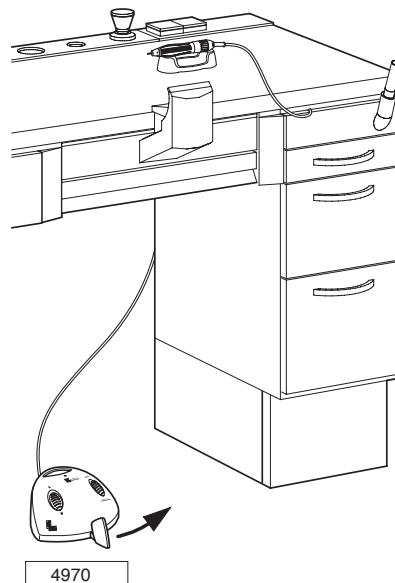

# K- Control 4960, 4965, 4970.

## A 9 Operating faults

**⚠** Repairs and servicing work on the electrical part of this equipment must only be undertaken by experts or by persons trained in our factory who are aware of the safety regulations. Disconnect the mains plug from the power supply, resp. switch off the disconnecting switch before carrying out any maintenance work.

**i** In K-Control knee and table-top control units, error messages are shown visually on the display ①. In the K-Control foot control unit, error messages are indicated by flashing of the malfunction LED ② (e.g. error message No. 7 = 7 x flashes, etc.).

**F** • Error display: F 0

- C** • Main processor not running
- R** • Repair or replace motor electronics

**F** • Error display: F 1

- C** • Overloading of motor, motor current above 4 A for 7 sec
- R** • Reduce motor load or stop and re-start with foot switch.

**F** • Error display: F 2

- C** • Handpiece blocked for more than 3 seconds
- R** • Eliminate blocking, stop and restart

**F** • Error display: F 3

- C** • No handpiece connected (also open circuit K9, K10)
- R** • Connect handpiece and restart

**F** • Error display: F 4

- C** • No handpiece connected (also open circuit K5, K11, K12, SF)
- R** • Connect handpiece and restart

**F** • Error display: F 6

- C** • Handpiece speed too high for longer than 2 seconds, a phase of the handpiece has been interrupted or electronics are faulty.
- R** • Repair handpiece or control unit

**F** = Fault **C** = Cause **R** = Rectification

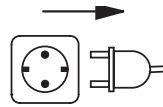

4965

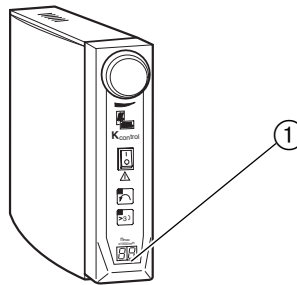

4960

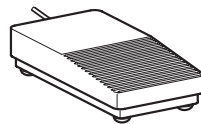
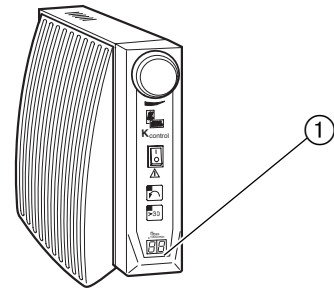

4620

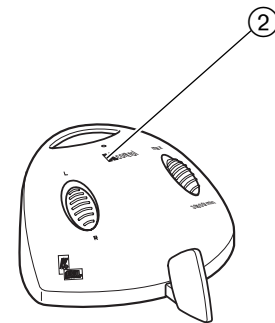

4970

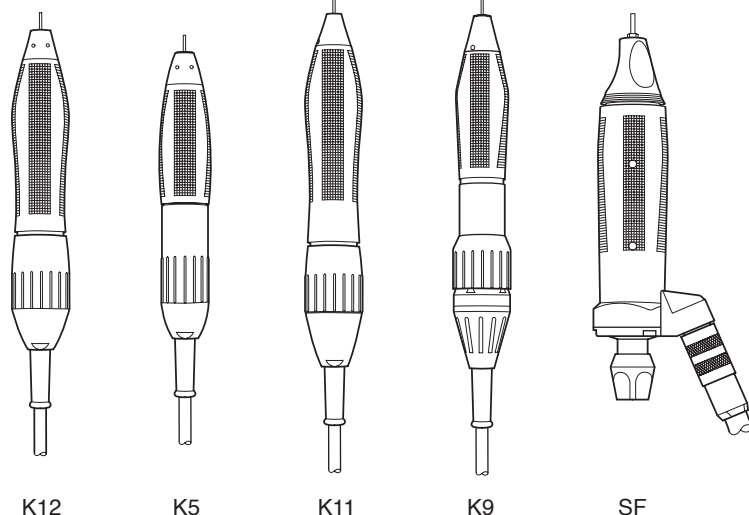

K12

K5

K11

K9

SF

# K- Control 4960, 4965, 4970.

**F** • Error display: F 9

- C** • Open circuit in speed potentiometer
- R** • Replace speed potentiometer with cable

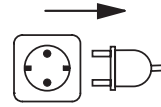

**F** • Error display: F 10

- C** • Magnets (Knee switch, Foot lever) inserted twisted
- R** • Insert magnets correct

4960

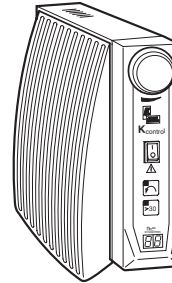

4965

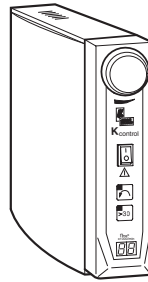

**F** • Error display: F 11

- C** • Fault in hall-effect element
- R** • For 3 seconds after switching the device on, a self-diagnosis program is automatically activated.
- R** • Repair control unit

**F** • Error display: F 13

- C** • Short-circuit in D.C. chopper transistor
- R** • Remedy: Repair control unit

**F** • Error display: F 14

- C** • Measuring device for motor voltage is faulty
- R** • Repair control unit

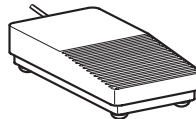

4620

**F** • Error display: F 17

- C** • Cooling attachment too hot (>90°)
- R** • Repair control unit

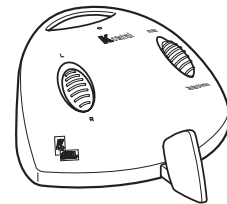

4970

**F** • Error display: F 18

- C** • Temperature sensor on cooling
- R** • Repair control unit (short-circuit)

**F** • Error display: F 19

- C** • Data loss in EEPROM
- R** • Repair or recalibration of the control unit



K12



K5



K11

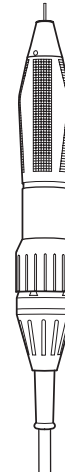

K9

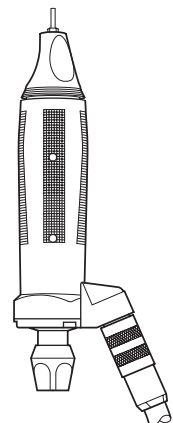

SF

**F** = Fault **C** = Cause **R** = Rectification

# K- Control 4960, 4965, 4970.

## **Guarantee provisions**

For the product cited in the transfer protocol, KaVo warrants the end customer that the product will function properly, have no material or manufacturing flaws for 12 months from the date of purchase under the following conditions:

In the case of valid complaints due to defects or a short delivery, KaVo will make good its warranty by replacing the product free of cost or repairing it according to your wishes. All other claims of any kind are excluded, especially claims for damages.

In case of delayed performance, gross negligence or criminal intent, this shall apply only if there are no compelling legal regulations to the contrary. KaVo is not liable for defects and their consequences that arise from natural wear, improper cleaning or servicing, the non-observance of instructions for use, servicing or connection, scale formation or corrosion, impurities in the air and water supply, or chemical or electrical influences that are unusual or impermissible according to the manufacturer's specifications.

The warranty does not generally extend to lamps, glassware, rubber parts and the colour fastness of plastic parts.

No liability is assumed when defects or their consequences can arise from manipulations or changes to the product by the customer or a third party.

Claims from this warranty can only be asserted when the transfer protocol (copy) belonging to the product has been sent to KaVo, and the original can be presented by the operator or user.



# K- Control 4960, 4965, 4970.

## 4960

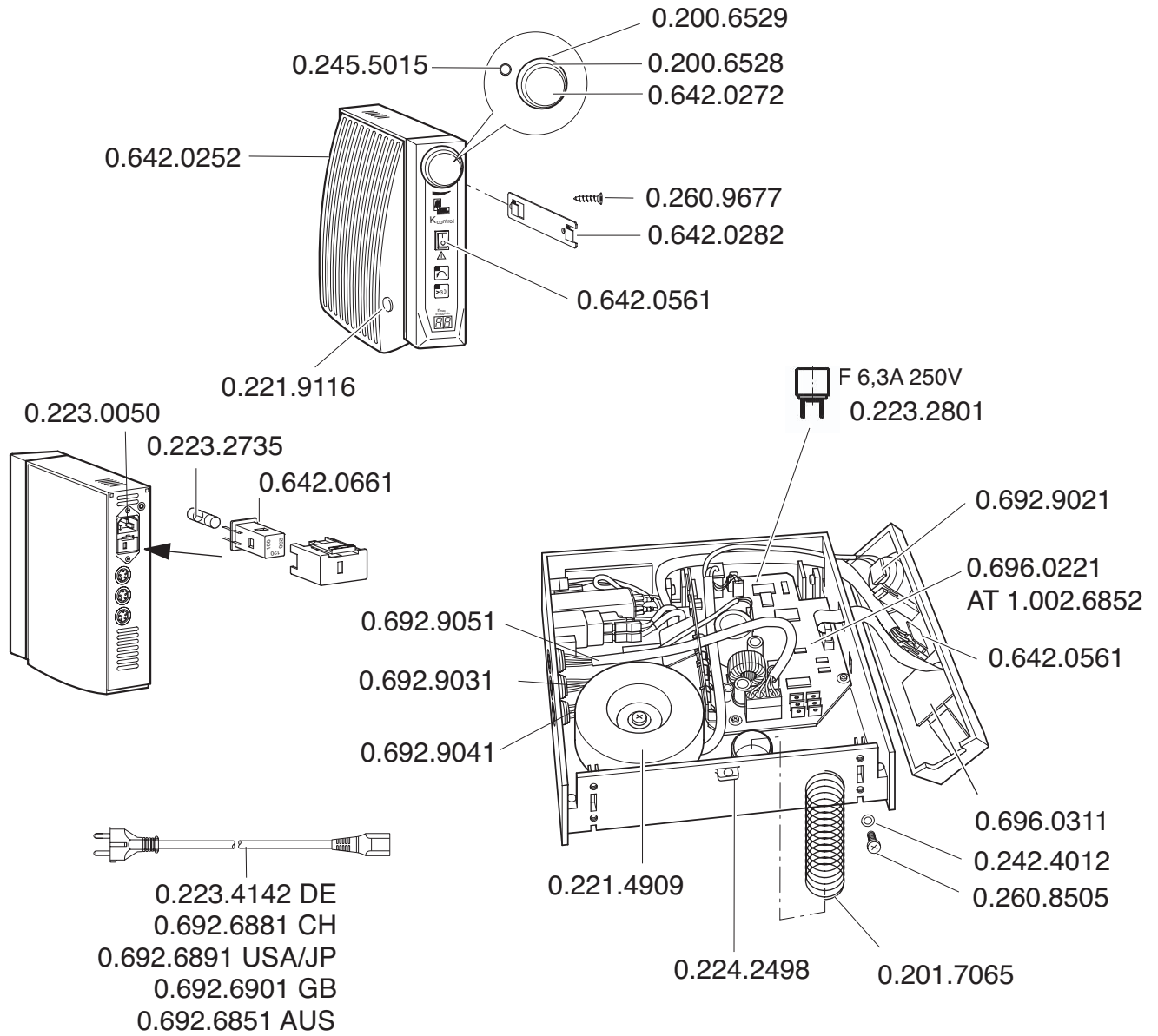

# K- Control 4960, 4965, 4970.

## 4965

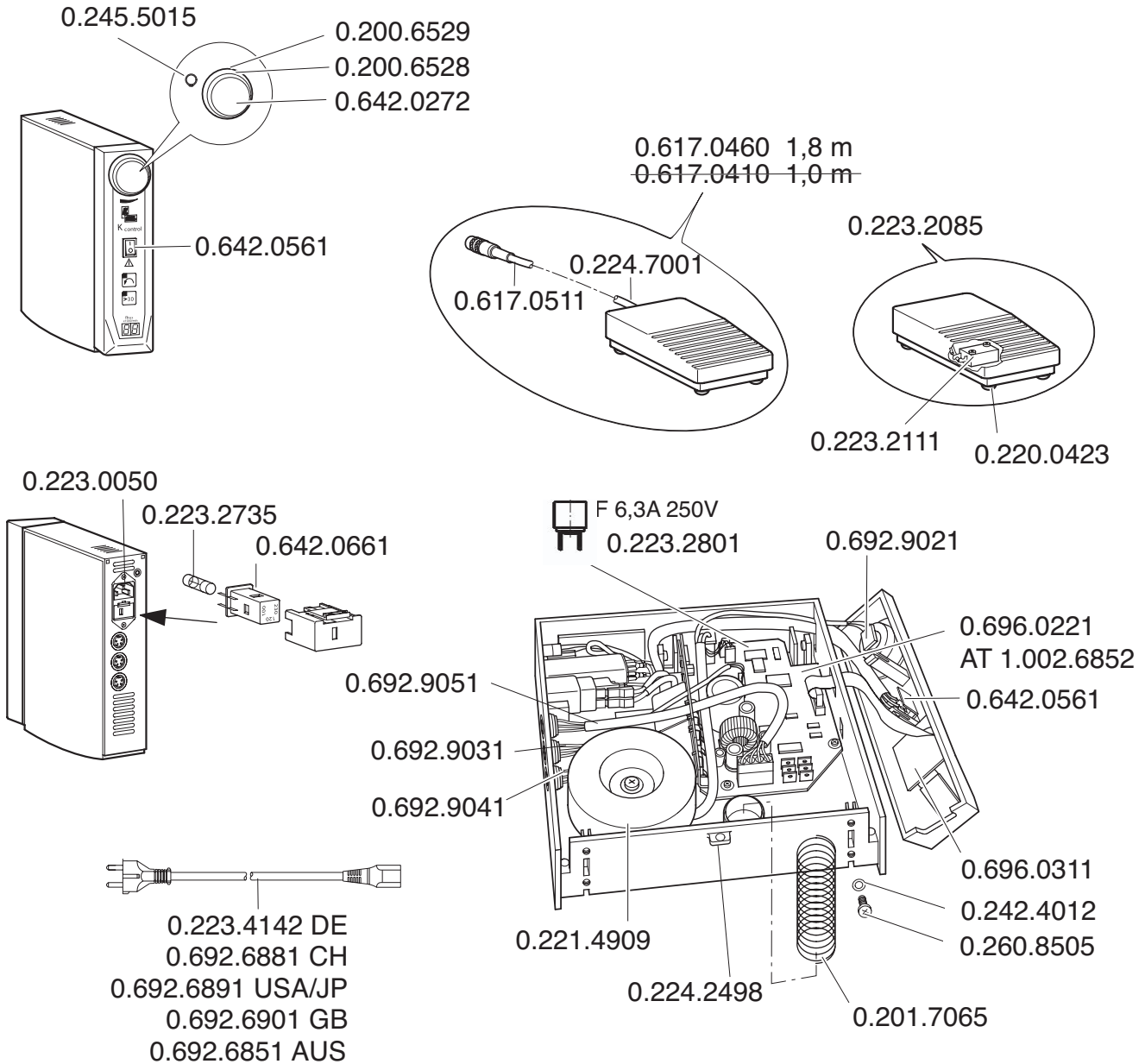

# K- Control 4960, 4965, 4970.

## 4970

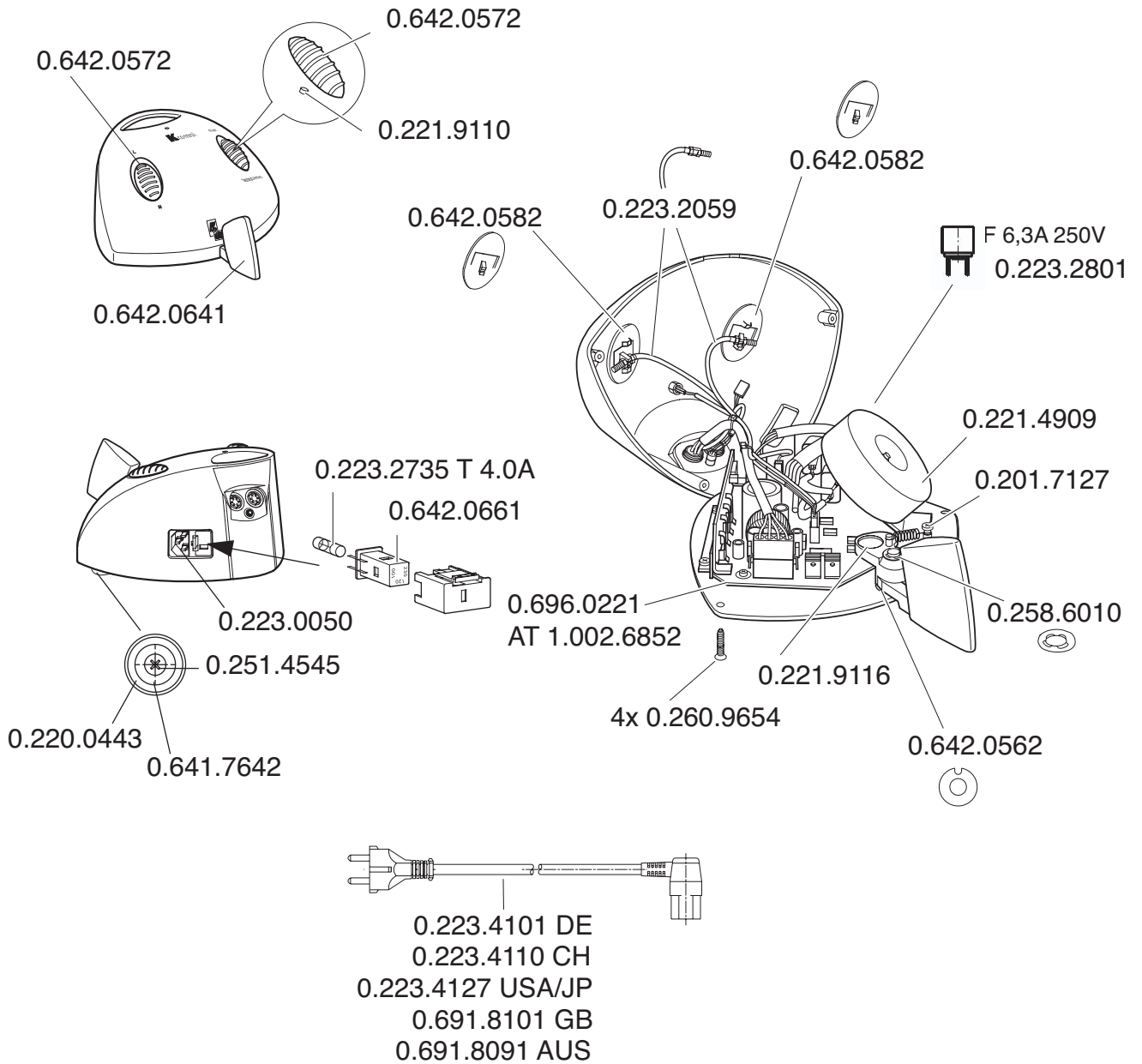

# K- Control 4960, 4965, 4970.



KaVo. Dental Excellence.

## EG-Konformitätserklärung EC-Conformity Statement

DE

GB

Wir, Kaltenbach & Voigt GmbH  
Bismarckring 39  
D-88400 Biberach

We, Kaltenbach & Voigt GmbH  
Bismarckring 39  
D-88400 Biberach

erklären, dass die von uns ab dem **05-2003** hergestellten  
Produkte

declare that the products

**Steuergeräte K – Control 4960 / 4965 / 4970  
Handstücke K5plus - 4911 / K9 - 960 / K9 - 970  
Handstücke K9 - 4930 / K-POWERgrip - 4941**

**Controller K – Control 4960 / 4965 / 4970  
Handpieces K5plus - 4911 / K9 - 960 / K9 - 970  
Handpieces K9 - 4930 / K-POWERgrip - 4941**

auf die sich diese Erklärung bezieht, übereinstimmen mit  
den Grundlegenden Anforderungen gemäß den  
Bestimmungen der Richtlinie

manufactured by us from **2003-05** onwards to which  
this statement refers, conform to the essential  
requirements according to the provisions of directive

**2006/95/EG EG-Niederspannungs-  
Richtlinie  
2004/108/EG EMV-Richtlinie**

**2006/95/EC EC Low Voltage Directive  
2004/108/EC EMC Directive**

Zur Beurteilung des Erzeugnisses wurden folgende  
Normen oder normativen Dokumente angewandt:

The following standards or normative documents were  
applied to evaluate the product:

**EN 61010-1 Sicherheitsbestimmungen für  
elektrische Mess-, Steuer-,  
Regel- und Laborgeräte –  
Teil 1: Allgemeine  
Anforderungen**

**EN 61010-1 Safety requirements for  
electrical equipment for  
measurement, control and  
laboratory use - Part 1:  
General requirements**

**EN 61326-1 Elektrische Betriebsmittel fuer  
Messtechnik, Leittechnik und  
Laboreinsatz.  
EMV - Anforderungen**

**EN 61326-1 Electrical equipment for  
measurement, control and  
laboratory use.  
EMC requirements**

Biberach, 2007-09-10

  
**Christoph Gusenleitner**

Geschäftsführer  
Managing Director

K- Control 4960, 4965, 4970.

# K- Control 4960, 4965, 4970.

## Drilling template

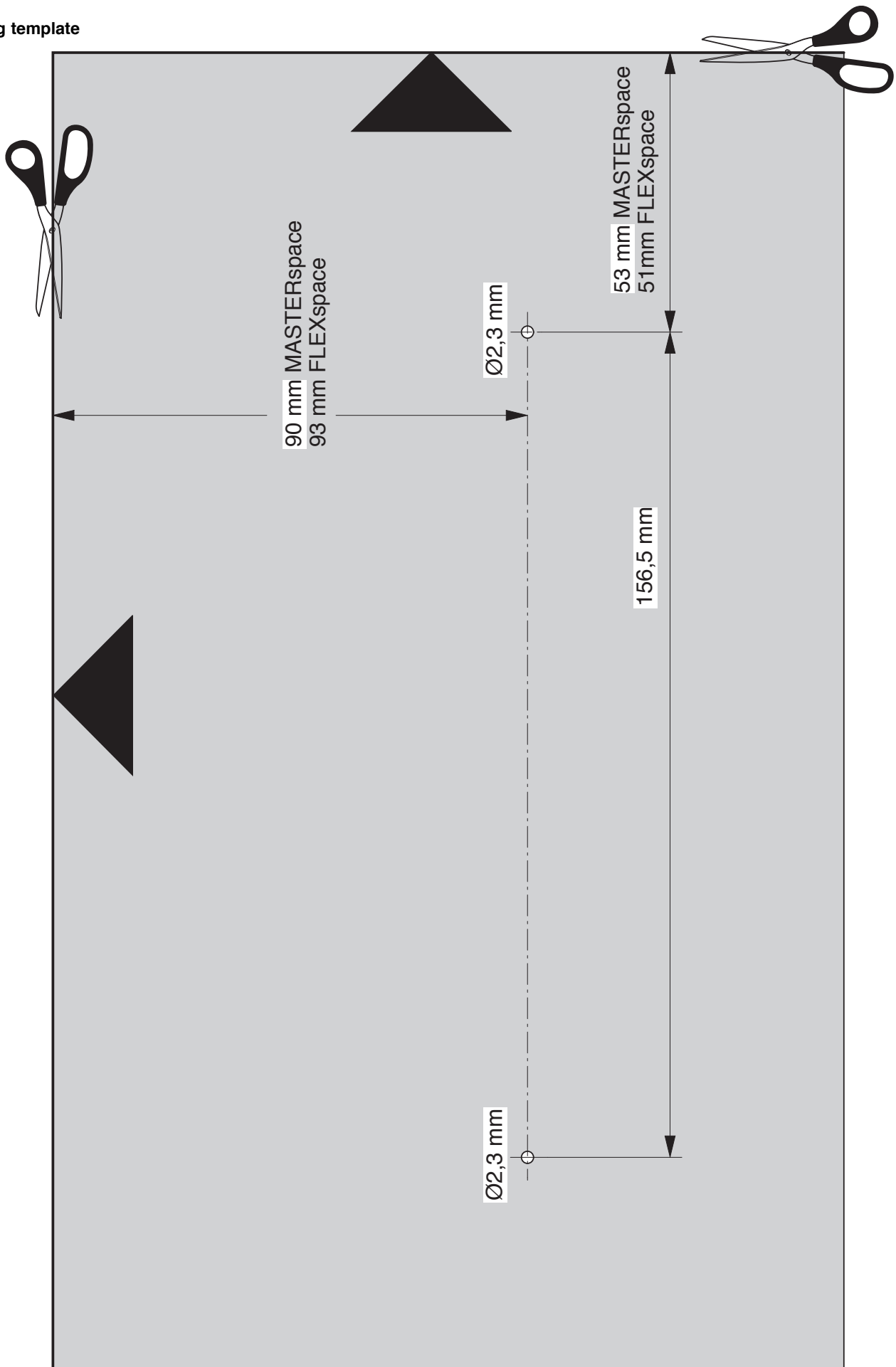





**KaVo. Dental Excellence.**

KaVo Dental GmbH. D-88400 Biberach/Riss  
Telefon +49 7351 56-0 Fax +49 7351 56-1488  
Internet: [www.kavo.com](http://www.kavo.com)