

# DYNACODE

Operating Manual



Copyright by Carl Valentin GmbH / 7957005.1015

Information on the scope of delivery, appearance, performance, dimensions and weight reflect our knowledge at the time of printing.

We reserve the rights to make modifications.

All rights, including those regarding the translation, are reserved.

No part of this document may be reproduced in any form (print, photocopy or any other method) or edited, copied or distributed electronically without written permission from Carl Valentin GmbH.

Due to the constant further development of our devices discrepancies between manual and device can occur.

Please check [www.carl-valentin.de](http://www.carl-valentin.de) for the latest update.

### **Trademarks**

All named brands or trademarks are registered brands or registered trademarks of their respective owners and may not be separately labelled. It must not be concluded from the missing labelling that it is not a registered brand or a registered trademark.

Carl Valentin direct print modules comply with the following safety guidelines:

- CE** EG Machinery Directive (98/37/EC)
- EG Low-Voltage Directive (2006/95/EC)
- EG Electromagnetic Compatibility Directive (89/336/EEC)



### **Carl Valentin GmbH**

Postfach 3744  
78026 Villingen-Schwenningen  
Neckarstraße 78 – 86 u. 94  
78056 Villingen-Schwenningen

Phone +49 (0)7720 9712-0  
Fax +49 (0)7720 9712-9901

E-Mail [info@carl-valentin.de](mailto:info@carl-valentin.de)  
Internet [www.carl-valentin.de](http://www.carl-valentin.de)

## Table of contents

<b>Table of contents</b> .....	<b>3</b>
<b>1 Important notes</b> .....	<b>5</b>
1.1 Intended use .....	5
1.2 Environmentally-friendly disposal.....	6
1.3 Figures.....	6
1.4 Continuous mode .....	8
1.5 Intermittent mode.....	9
<b>2 Safety notes</b> .....	<b>11</b>
2.1 Warnings .....	12
2.2 Operating conditions.....	13
<b>3 Technical data</b> .....	<b>17</b>
3.1 Control inputs and outputs (standard).....	18
3.2 Control inputs and outputs (option) .....	23
3.3 Plug & Play .....	27
3.4 Pin assignment of encoder socket .....	28
<b>4 Installation and Initiation</b> .....	<b>29</b>
4.1 Installation of print mechanics at machines .....	30
4.2 Connection of pneumatic power supply .....	32
4.3 Adjustment of pressure power.....	33
4.4 Connecting the direct print module.....	34
4.5 Before initial operation.....	34
4.6 Print control .....	35
4.7 Initiation .....	35
<b>5 Loading ribbon cassette</b> .....	<b>37</b>
5.1 Ribbon coating outside.....	37
5.2 Ribbon coating inside .....	38
5.3 Increasing the clamping force for ribbon roll .....	39
<b>6 Foil keyboard</b> .....	<b>41</b>
6.1 Keyboard assignment (standard) .....	41
6.2 Keyboard assignment (text entry/customized) .....	42
<b>7 Function menu</b> .....	<b>45</b>
7.1 Menu structure (continuous mode).....	45
7.2 Menu structure (intermittent mode) .....	47
7.3 Print settings.....	49
7.4 Machine parameters (continuous mode).....	50
7.5 Machine parameters (intermittent mode) .....	52
7.6 Layout settings .....	54
7.7 Ribbon save (continuous mode).....	55
7.8 Ribbon save (intermittent mode) .....	56
7.9 Device settings .....	57
7.10 I/O parameters.....	59
7.11 Network .....	60
7.12 Remote console.....	60
7.13 Interface.....	61
7.14 Emulation.....	62
7.15 Date & time .....	63
7.16 Service functions .....	64
7.17 Main menu .....	67
7.18 Display during printing.....	69
<b>8 Compact Flash card</b> .....	<b>71</b>

<b>9</b>	<b>Maintenance and cleaning.....</b>	<b>75</b>
9.1	Cleaning the printhead .....	75
9.2	Replacing the printhead .....	75
9.3	Angle adjustment* .....	77
9.4	Print quality optimisation .....	78
9.5	Cycle optimisation* .....	79
<b>10</b>	<b>Signal diagrams.....</b>	<b>81</b>
10.1	Continuous mode .....	81
10.2	Intermittent mode.....	85
<b>11</b>	<b>Error correction .....</b>	<b>87</b>
<b>12</b>	<b>Additional information .....</b>	<b>97</b>
12.1	Column printing .....	97
12.2	Password.....	98
12.3	Hotstart.....	100
<b>13</b>	<b>Ribbon save .....</b>	<b>101</b>
13.1	Explication .....	101
13.2	Standard ribbon save (continuous mode) .....	102
13.3	Shift ribbon save (continuous mode).....	105
13.4	SaveStrt ribbon save (continuous mode) .....	108
13.5	Standard ribbon save (intermittent mode).....	109
13.6	Shift ribbon save (intermittent mode) .....	110
<b>14</b>	<b>Index .....</b>	<b>111</b>

# 1 Important notes

The Dynacode is equipped with 8 vector, 6 bitmap and 6 proportional fonts. It is possible to print inverse, in italic format or 90 degrees turned fonts.

The handling of our durable print module is easy and comfortable. The settings are made with the keys of the foil keyboard. At each time the two-line display shows the current status.

An enormously high print quality is obtained by most modern printhead technology.

By a new-developed electronics a maximum print speed of up to 800 mm/s (continuous mode) and 600 mm/s (intermittent mode) can be achieved. Time-saving update of the print module software is possible via the interface. The print module can be adapted by the large selection of options to each function.

As default, the print module is equipped with a parallel, serial, USB and Ethernet interface. The device automatically recognizes by which interface it is controlled.

Time-saving update is possible by interface.

Thanks to the large number of options the print module can be adapted to each task.

## 1.1 Intended use

The continuous and intermittent operating Dynacode is a direct print module with high resolution for installation in horizontal and vertical packaging machines. Not only the easy to change ribbon cassette is convincing but also different print widths, left and right versions and because of the separate control unit it is possible to integrate the Dynacode almost in each packaging process without any problems. Flexible labelling of packaging foil is effected either by means of Windows printer driver included in delivery or by our proven creation software.

The direct print module is a state-of-the-art device which complies with the recognized safety-related rules and regulations. Despite this, a danger to life and limb of the user or third parties could arise and the direct print module or other property could be damaged while operating the device.

The direct print module may only be used while in proper working order and for the intended purpose. Users must be safe, aware of potential dangers and must comply with the operating instructions. Faults, in particular those which affect safety, must be remedied immediately.

The direct print module is solely intended to print suitable media which have been approved by the manufacturer. Any other or additional use is not intended. The manufacturer/supplier is not liable for damage resulting from misuse. Any misuse is at your own risk.

Intended used includes heeding the operating manual, including the maintenance recommendations/regulations specified by the manufacturer.

## 1.2 Environmentally-friendly disposal

Manufacturers of B2B equipment are obliged to take back and dispose of old equipment that was manufactured after 13 August 2005. As a principle, this old equipment may not be delivered to communal collecting points. It may only be organised, used and disposed of by the manufacturer. Valentin products accordingly labelled can therefore be returned to Carl Valentin GmbH.

This way, you can be sure your old equipment will be disposed of correctly.

Carl Valentin GmbH thereby fulfils all obligations regarding timely disposal of old equipment and facilitates the smooth reselling of these products. Please understand that we can only take back equipment that is sent free of carriage charges.

Further information on the WEEE directive is available on our website [www.carl-valentin.de](http://www.carl-valentin.de).

## 1.3 Figures

Connection side of  
print mechanics

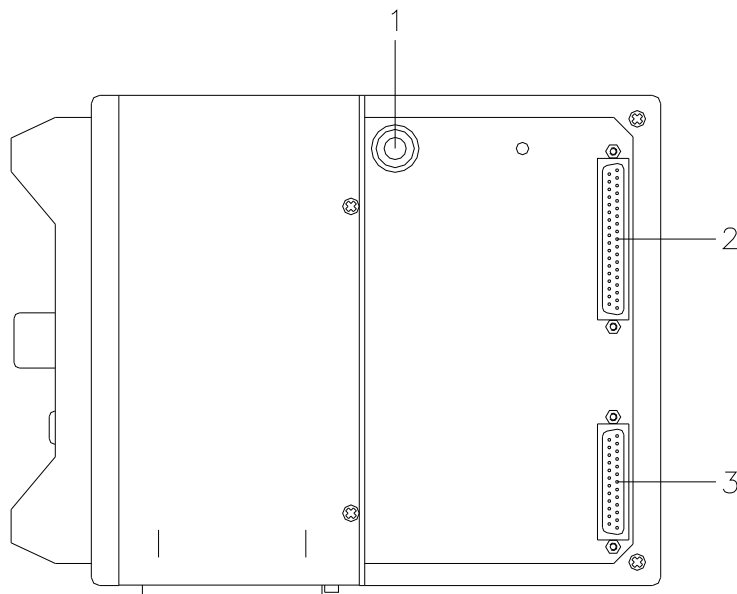

**Figure 1**

- 1 = Pneumatic connection
- 2 = Connecting cable SPI (printhead + sensors)
- 3 = Connecting cable power

### Connector assignment of control unit

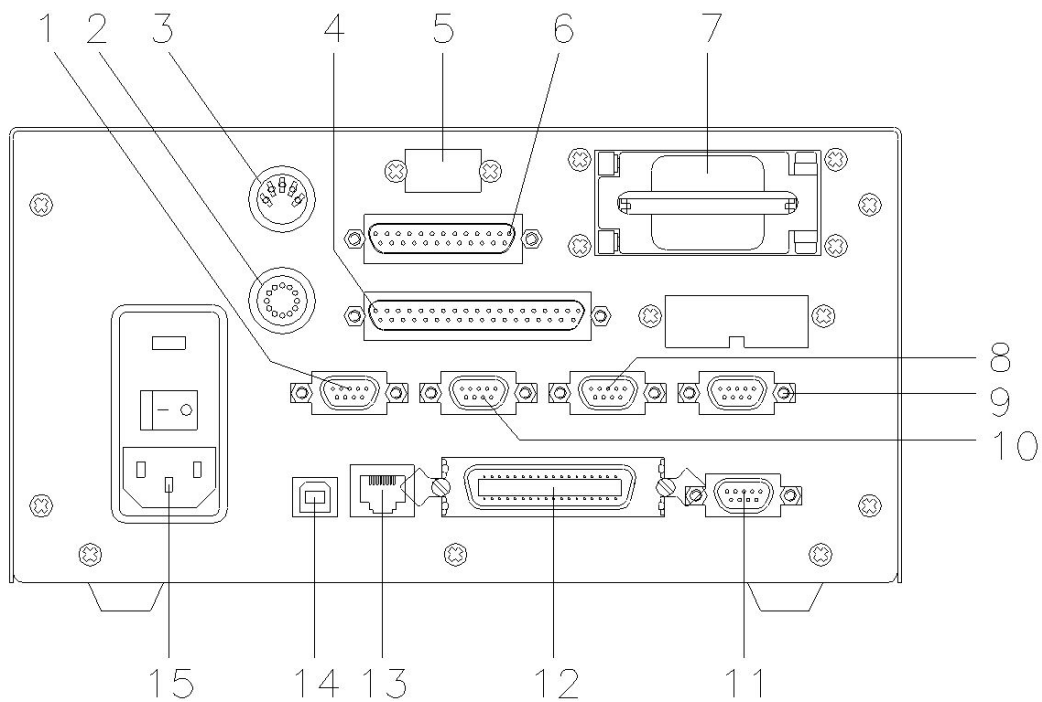

**Figure 2**

- |      |  |                         |
|------|--|-------------------------|
| 1 =  | External output 1-4 (Output I)                   |                         |
| 2 =  | Touch panel connection                           |                         |
| 3 =  | Encoder connection                               |                         |
| 4 =  | Connecting cable SPI (printhead + sensor)        |                         |
| 5 =  | Placeholder for second serial interface (option) |                         |
| 6 =  | Connecting cable 'power'                         |                         |
| 7 =  | Compact Flash card slot                          |                         |
| 8 =  | External output 5-8 (Output II)                  |                         |
| 9 =  | Standard   | Option                  |
|      | SUB-D plug 9-pin                                 | SUB-D plug 15-pin       |
|      | External input 5-8                               | External bushing I/O-24 |
|      | see chapter 3.1                                  | see chapter 3.1         |
| 10 = | Extrnal input 1-4 (Input I)                      |                         |
| 11 = | RS 232 interface                                 |                         |
| 12 = | Centronics interface                             |                         |
| 13 = | Ethernet interface                               |                         |
| 14 = | USB interface                                    |                         |
| 15 = | Power supply with switch                         |                         |

## 1.4 Continuous mode

### Material speed

Please note that the material has sufficient adhesion at the pressure transducer roll or encoder roll to permit the exact speed by the encoder.

It is only possible to print when respecting the operating conditions, i.e. the speed has to be observed.

### Print principle

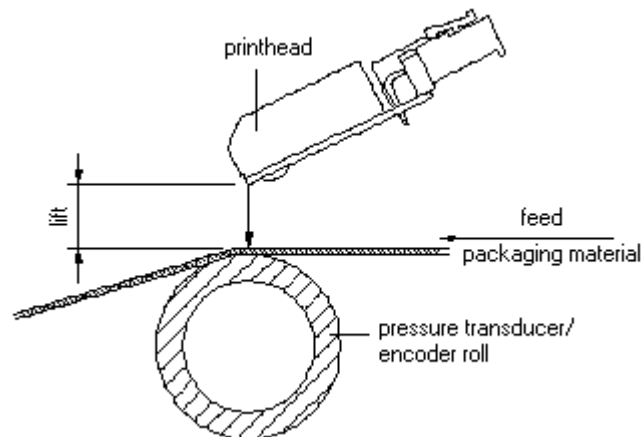

**Figure 3**

After starting a print order the printhead moves against the print medium. The feed of material is registered by the encoder and then evaluated. The printhead is in start position as long as the printing onto the moving material is finished and then it moves back to its home position.

### Material guiding



In case the encoder is connected to the counter-pressure roll or the encoder roll you have to observe that the material has sufficient adhesion at the pressure roll or encoder roll to guarantee an exact speed by the encoder.

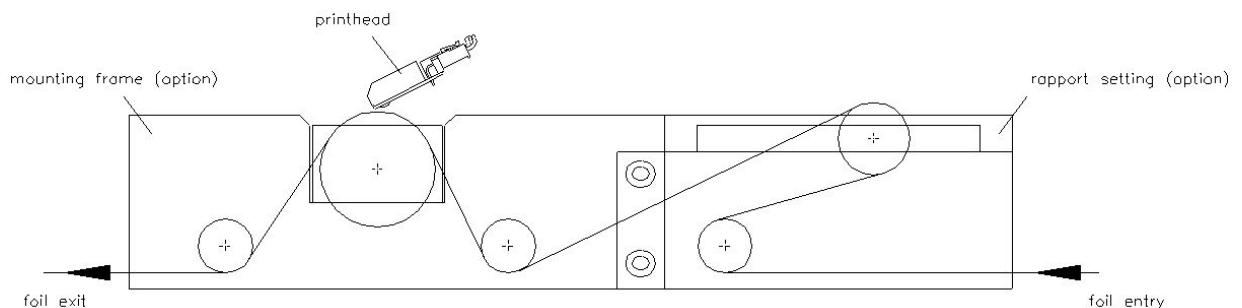
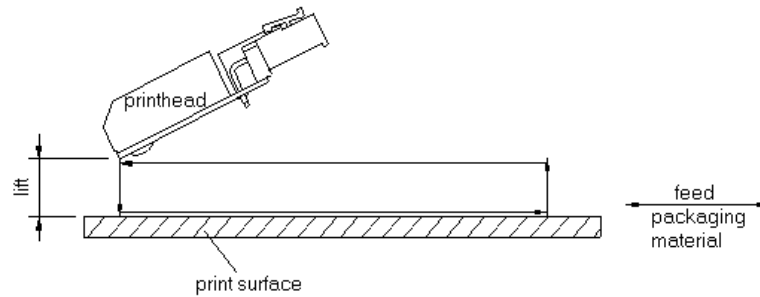

**Figure 4**



## 1.5 Intermittent mode

### Print principle



**Figure 5**

After starting a print order the printhead moves against the print medium. Afterwards the printing carriage moves corresponding to the set or transferred layout length linear over the material which is to be printed. After the print procedure the printhead again lifts up and the printing carriage moves again to the starting position.

### Print position



The direct print module is delivered with a default print length of 65 mm. In order to use the maximum print length, the print position value must be changed to 93 (see chapter 7.5. Machine parameters (intermittent mode), page 52).

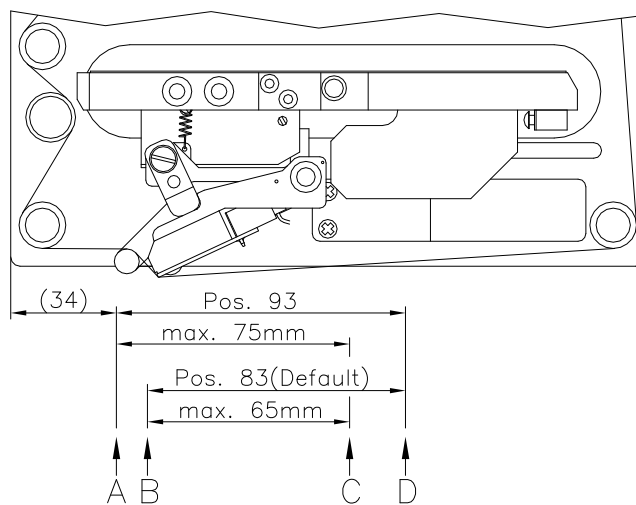

A: Print position/start position value = 93 mm

B: Print position/start position value = 83

C: Max. position print end

D: Stand-by position



## 2 Safety notes

The direct print module is designed for power supply systems from 110 V to 230 V. Connect the direct print module only to electrical outlets with a ground contact.

**NOTICE!**

When changing the mains voltage the fuse value is to adapt accordingly (see 'Technical data').

Couple the direct print module to devices using extra low voltage only.

Before making or undoing connections, switch off all devices involved (computer, printer, accessories etc.).

Operate the direct print module in a dry environment only and do not get it wet (sprayed water, mist etc.).

Do not operate the direct print module in explosive atmosphere and not in proximity of high voltage power lines.

Operate the direct print module only in an environment protected against abrasive dust, swarf and other similar impurity.

In case of cleaning and maintenance with an open cover, ensure that clothing, hair, jewellery and similar personal items do not contact the exposed rotating parts.

**NOTICE!**

With the open printing unit (due to construction) the requirements of EN60950-1 regarding fire protection casing are not fulfilled. These must be ensured by the installation into the end device.

The print unit can get hot during printing. Do not touch the printhead during operation. Cool down the print unit before changing material, removal or adjustment.

Carry out only the actions described in these operating instructions. Any work beyond this may only be performed by the manufacturer or upon agreement with the manufacturer.

Unauthorized interference with electronic modules or their software can cause malfunctions.

Other unauthorized work or modifications to the direct print module can endanger operational safety.

Always have service work done in a qualified workshop, where the personnel have the technical knowledge and tools required to do the necessary work.

There are warning stickers on the direct print modules that draw your attention to dangers. Therefore the warning stickers are not to be removed as then you and others cannot be aware of dangers and may be injured.

The direct printing unit must be integrated with the Emergency Stop circuit when it is incorporated into the overall machine.

All isolating safety equipment must be installed before starting-up the machine.



**DANGER!**

Danger to life and limb from power supply!

⇒ Do not open the casing.

## 2.1 Warnings

Warnings are presented with three signal words for the different levels of danger.

**DANGER** identifies an extraordinarily great and immediate danger which could lead to serious injury or even death.

**WARNING** identifies a possible danger which could lead to serious bodily injury or even death if sufficient precautions are not taken.

**CAUTION** indicates a potentially dangerous situation which could lead to moderate or light bodily injury or damage to property.

## 2.2 Operating conditions

Before initial operation and during operation these operating conditions have to be observed to guarantee safe and interference-free service of our devices.

Therefore please carefully read these operating conditions.

Shipment and storage of our devices are only allowed in original packing.

Installation and initial operation of direct print module is only allowed if operating conditions were fulfilled.

Commissioning is prohibited until it can be established that, where relevant, the machine into which the partly completed machinery is to be incorporated complies with the provisions of Machinery Directive 2006/42/EC.

Initial operation, programming, operation, cleaning and service of our direct print modules are only recommended after careful study of our manuals.

Operation of direct print module is only allowed by especially trained persons.

Perform trainings regularly.



Content of the training are chapter 2.2 (Operating conditions), chapter 5 (Loading ribbon cassette) and chapter 9 (Maintenance and cleaning).

These indications are also valid for someone else's equipment supplied by us.

Only use original spare and exchange parts.

Please contact the manufacturer with respect to spare/wear parts.

### Instructions for lithium battery

CPU of direct print module is equipped with a lithium battery (type CR 2032) for which the battery regulation is to apply. This regulation plans that unloaded batteries have to be given to used battery collecting containers of trade and public carries. In case that batteries were not completely discharged you have to make arrangements for short-circuits. At a shutdown of direct print module the battery has to be disposed in either case separately from direct print module.



#### **DANGER!**

Danger of life by explosion!

⇒ Use nonconducting tools.

### Conditions for installation place

The installation place of direct print module should be even, free of vibration and currents of air are to be avoided.

The direct print modules have to be installed to ensure optimal operation and servicing.

**Installation of power supply**

The installation of the power supply to connect our direct print modules has to be effected according to the international rules and regulations, especially the recommendations of one of the three following commissions:

- International Electronic Commission (IEC)
- European Committee for Electro technical Standardisation (CENELEC)
- Verband Deutscher Elektrotechniker (VDE)

Our direct print modules are constructed according to VDE and have to be connected to a grounded conductor. The power supply has to be equipped with a grounded conductor to eliminate internal interfering voltage.

**Technical data of power supply**

Power line voltage and power line frequency: See type plate  
 Allow. tolerance of power line voltage: +6% ... -10% of nominal value  
 Allow. tolerance of power line frequency: +2% ... -2% of nominal value  
 Allowable distortion factor of power line voltage:  $\leq 5\%$

**Anti-Interference measures:**

In case your net is infected (e.g. by using thyristor controlled machines) anti-interference measures have to be taken. You can use one of the following possibilities:

- Provide separate power supply to our direct print modules.
- In case of problems please connect capacity-decoupled isolation transformer or similar interference suppressor in front of our direct print modules.

**Stray radiation and immunity from disturbance**

Emitted interference according to EN 61000-6-4: 08-2002

- Interference voltage to wires according to EN 55022: 09-2003
- Interference field power according to EN 55022: 09-2003
- System perturbation according to EN 61000-3-2: 09-2005
- Flicker according to EN 61000-3-3: 05-2002

Immunity to interference according to EN 61000-6-2: 03-2006

- Stray radiation against discharge of static electricity according to EN 61000-4-2: 12-2001
- Electromagnetic fields according to EN 61000-4-3: 11-2003
- Fast transient burst according to EN 61000-4-4: 07-2005
- Surge according to EN 61000-4-5: 12-2001
- High-frequency tension according to EN 61000-4-6: 12-2001
- Voltage interruption and voltage drop according to EN 61000-4-11: 02-2005



This is a machine of type A. This machine can cause interferences in residential areas; in this case it can be required from operator to accomplish appropriate measures and be responsible for it.

**Machine safety**

- EN 415-2 - Safety of packaging machines
- EN 60204-1:2006 - Safety of machinery - Electrical equipment of machines - Part 1

**Connecting lines to external machines**

All connecting lines have to be guided in shielded lines. Shielding has to be connected on both sides to the corner shell.

It is not allowed to guide lines parallel to power lines. If a parallel guiding cannot be avoided a distance of at least 0.5 m has to be observed.

Temperature of lines between: -15 ... +80 °C.

It is only allowed to connect devices which fulfil the request 'Safety Extra Low Voltage' (SELV). These are generally devices which are checked corresponding to EN 60950.

**Installation of data lines**

The data cables must be completely protected and provide with metal or metallised connector housings. Shielded cables and connectors are necessary, in order to avoid radiant emittance and receipt of electrical disturbances.

## Allowable lines

Shielded line:                    4 x 2 x 0,14 mm<sup>2</sup> ( 4 x 2 x AWG 26)  
     6 x 2 x 0,14 mm<sup>2</sup> ( 6 x 2 x AWG 26)  
     12 x 2 x 0,14 mm<sup>2</sup> (12 x 2 x AWG 26)

Maximum line length:    interface V 24 (RS-232C) - 3 m at max. 19200 bds  
     Centronics - 3 m  
     USB - 3 m  
     Ethernet - 100 m

**Air convection**

To avoid inadmissible heating, free air convection has to be ensured.

**Limit values**

Protection according IP: 20

Ambient temperature °C (operation): Min. +5 Max. +40

Ambient temperature °C (transport, storage): Min. -25 Max. +60

Relative air humidity % (operation): Max. 80

Relative air humidity % (transport, storage): Max. 80  
 (bedewing of direct print modules not allowed)

**Guarantee**

We do not take any responsibility for damage caused by:

- Ignoring our operating conditions and operating manual.
- Incorrect electric installation of environment.
- Building alterations of our direct print modules.
- Incorrect programming and operation.
- Not performed data protection.
- Using of not original spare parts and accessories.
- Natural wear and tear.

When (re)installing or programming our direct print modules please control the new settings by test running and test printing. Herewith you avoid faulty results, reports and evaluation.

Only specially trained staff is allowed to operate the direct print modules.

Control the correct handling of our products and repeat training.

We do not guarantee that all features described in this manual exist in all models. Caused by our efforts to continue further development and improvement, technical data might change without notice.

By further developments or regulations of the country illustrations and examples shown in the manual can be different from the delivered model.

Please pay attention to the information about admissible print media and the notes to the direct print module maintenance, in order to avoid damages or premature wear.

We endeavoured to write this manual in an understandable form to give and you as much as possible information. If you have any queries or if you discover errors, please inform us to give us the possibility to correct and improve our manual.



### 3 Technical data

	Dynacode 53	Dynacode 107	Dynacode 128
Print width	53,3 mm	106,6 mm	128 mm
Frame passage width	customized		
<b>Print length</b> Continuous mode Intermittent mode	6000 mm 75 mm	3000 mm 75 mm	3000 mm 75 mm
Resolution	300 dpi		
<b>Print speed</b> Continuous mode Intermittent mode	50 ... 800 mm/s 50 ... 600 mm/s	50 ... 600 mm/s 50 ... 600 mm/s	50 ... 450 mm/s 50 ... 600 mm/s
Back speed	only intermittent mode: max. 600 mm/s		
Printhead	Corner Type		
<b>Acoustic emission</b> Average sound pressure level	Measuring dist. 1 m 60 dB(A)	Measuring dist. 1 m 65 dB(A)	Measuring dist. 1 m 68 dB(A)
Built-in fonts	8 vector fonts 6 bitmap fonts, 6 proportional fonts font height: min. 1 mm - max. 99 mm		
1D bar codes	CODABAR, Code 128, Code 2/5 interleaved, Code 39, Code 39 ext., Code 93, EAN 13, EAN 8, EAN ADD ON, GS1-128, Identcode, ITF 14, Leitcode, Pharmacode, PZN 7 Code, PZN 8 Code, UPC-A, UPC-E		
2D bar codes	Aztec Code, CODABLOCK F, DataMatrix, GS1 DataMatrix, MAXICODE, PDF 417, QR Code		
Composite bar codes	GS1 DataBar Expanded, GS1 DataBar Limited, GS1 DataBar Omnidirectional, GS1 DataBar Stacked, GS1 DataBar Stacked Omnidirectional, GS1 DataBar Truncated		
<b>Interface</b>	serial: RS-232C (up to 115200 baud) - parallel: Centronics USB: 1.1 - Ethernet: 10/100 Base-T		
<b>Transfer ribbon</b> Core diameter Max. length Max. width Coating outside	25,4 mm / 1" 900 m (Ø 98 mm) 55 mm inside (option)	25,4 mm / 1" 600 m (Ø 82 mm) 110 mm inside (option)	25,4 mm / 1" 450 m (Ø 75 mm) 130 mm inside (option)
<b>Dimensions in mm</b> (width x height x depth)			
Print mechanics without mounting frame with mounting frame Control unit	204 x 180 x 234 depends on passage width 240 x 125 x 332 - connecting cable to mechanics 2,5 m	204 x 180 x 290	204 x 180 x 312
<b>Weight</b> Print mechanics Electronics (incl. cable)	9,5 kg 5,5 kg	11 kg 5,5 kg	11,7 kg 5,5 kg
<b>Connection values</b> Pneumatic connection Nominal voltage Nominal current Fuse values	min. 6 bar dry and free of oil 110 ... 230 V / 50 ... 60 Hz 230 V / 1,5 A – 110 V / 3 A 230 V / 2 AT – 110 V / 4 AT		
<b>Operating conditions</b> Temperature Relative humidity	5 ... 40 °C max. 80% (non-condensing)		

Technical modifications are subject to change.

### 3.1 Control inputs and outputs (standard)

#### Plug connection - back side of control unit

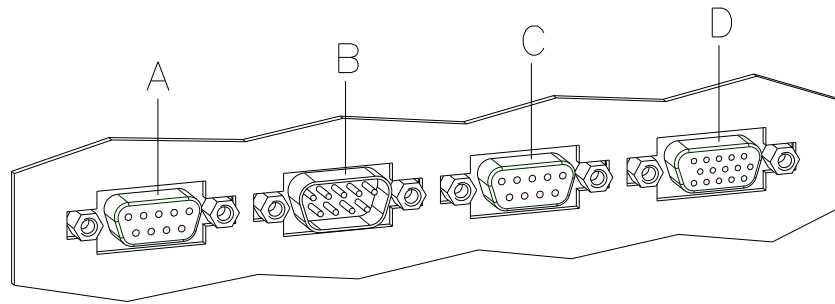

**Figure 6**

- A = External output 1-4 (Output I)
- B = External input 1-4 (Input I)
- C = External output 5-8 (Output II)
- D = External bushing 15pin (I/O-24)

#### Control outputs

By means of the signal outputs different operating states of the print module can be queried.

The signal outputs are provided by two 9-pin SUB-D-bushings (OUTPUT I and OUTPUT II) on the back side of the control unit.

They consist of optocoupler semiconductor sections, which are connected through and/or blocked according to different operating states.

The maximum allowable current in a semiconductor section is  $I_{max} = 30 \text{ mA}$ .

Output I  
Figure 6, A

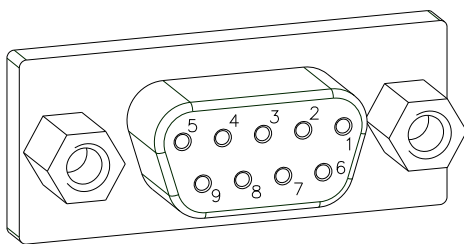
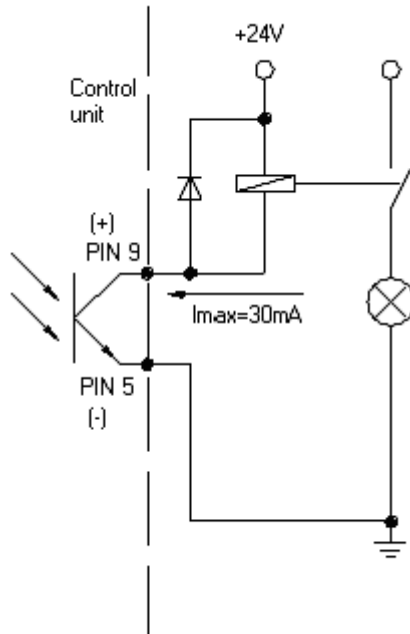

**Figure 7**

PIN (bushing)	Output I
	Out 1: Error message Each error status such as ribbon error is displayed.
	Out 2: Print order The print module was activated by a print order.
	Out 3: Generation The print module is filled with current layout data.
	Out 4: Layout print The content of print memory is transferred on the printable medium by means of the printhead.

**Example**

Connection of a lamp to a 24V relay by Out 1:



**Figure 8**

Output II  
Figure 6, C

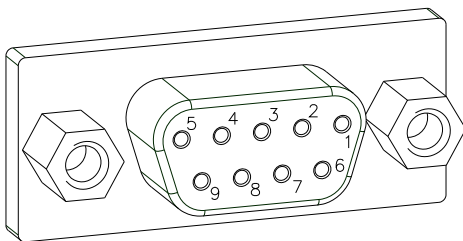

**Figure 9**

PIN (bushing)	Output II
<p>9 (+) 5 (-)</p>	<p>Out 5: Print-Ready signal</p> <p>It is indicated if the print module is ready to process a start impulse. In contrary to the print order signal, the generating time is taken into consideration.</p>
<p>8 (+) 7 (-)</p>	<p>Out 6: Printhead up</p> <p>The printhead has reached the upper rest position (e.g. return to zero point).</p>
<p>6 (+) 2 (-)</p>	<p>Out 7: Return to start</p> <p>After termination of print procedure the flexible part of the print module is moved back to the start position. After the start position was reached a new start can be released.</p>
<p>4 (+) 3 (-)</p>	<p>Out 8: Prior warning of transfer ribbon end</p>

**Control inputs**

By means of the control inputs it is possible to control printing. The control inputs at Input I are galvanic separated and have to be provided with an external tension source. The signal level is active "HIGH".

Input I  
Figure 6, B

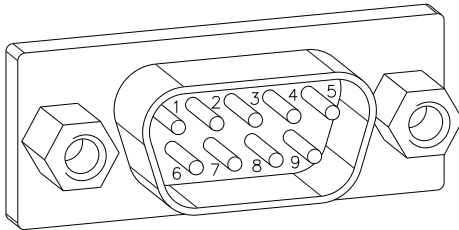
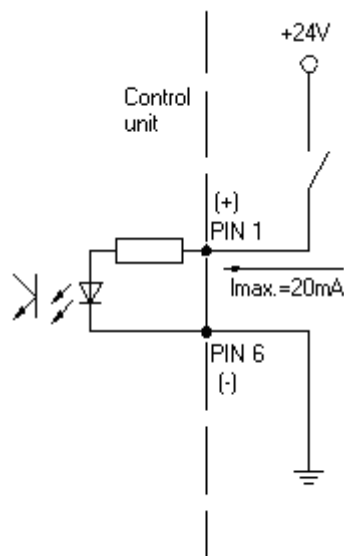

**Figure 10**

PIN (pin)	Input I
<p>1 (+) 6 (-)</p>	In 1: Print start
<p>7 (+) 2 (-)</p>	In 2: Not used
<p>8 (+) 9 (-)</p>	In 3: Reset external counter
<p>4 (+) 3 (-)</p>	In 4: Not used

**Example**

Connection of a switch with 24V voltage supply by In 1:



**Figure 11**

**External bushing I/O-24**

Figure 6, D

This input is executed as 15-pole and provides user-sided 24V/100mA.

In case of using this bushing, exists **no galvanic separation**.

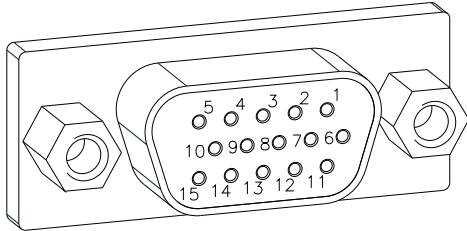

**Figure 12**

PIN	Function
1, 6	Gnd
5, 10	24 V / 100 mA
3	Print start (NPN initiator)
2	Print start (PNP initiator)
4	Print start by potential-free contact
14	
7	Signal lamp 24 V / 100 mA (error)
13	

**Pin assignment**

PIN 1	white
PIN 2	brown
PIN 3	green
PIN 4	yellow
PIN 5	grey
PIN 6	pink
PIN 7	blue
PIN 8	red
PIN 9	black
PIN 10	purple
PIN 11	grey-pink
PIN 12	red-blue
PIN 13	white-green
PIN 14	brown-green
PIN 15	free

**Example 1**

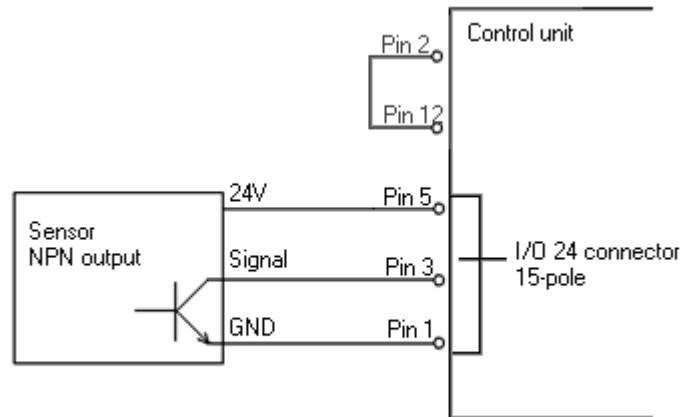

Connection scheme for creating a start signal by a sensor with NPN output

**Example 2**

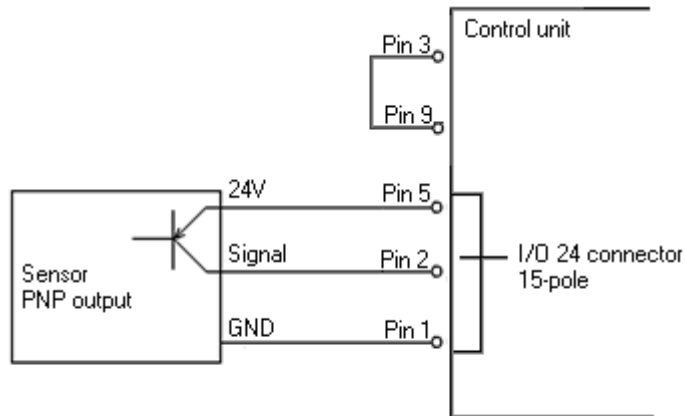

Connection scheme for creating a start signal by a sensor with PNP output

**Example 3**

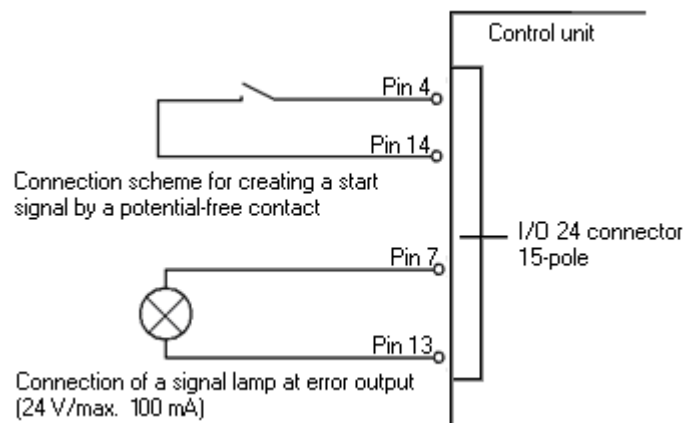

### 3.2 Control inputs and outputs (option)

#### Plug connection - back side of control unit

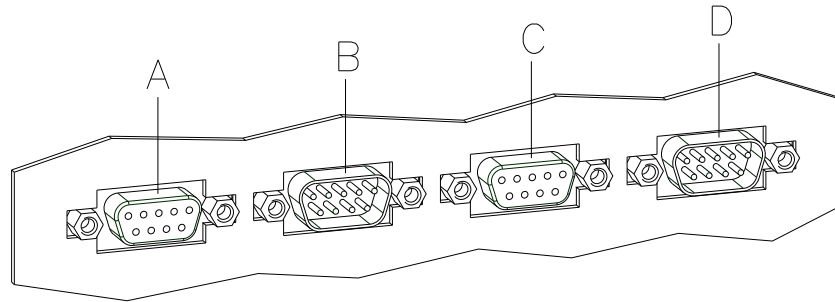

**Figure 13**

- A = External output 1-4 (Output I)
- B = External input 1-4 (Input I)
- C = External output 5-8 (Output II)
- D = External input 5-8 (Input II)

#### Control outputs

By means of the signal outputs different operating states of the print module can be queried.

The signal outputs are provided by two 9-pin SUB-D-bushings (OUTPUT I and OUTPUT II) on the back side of the control unit.

They consist of optocoupler semiconductor sections, which are connected through and/or blocked according to different operating states.

The maximum allowable current in a semiconductor section is  $I_{max} = 30 \text{ mA}$ .

Output I  
Figure 13, A

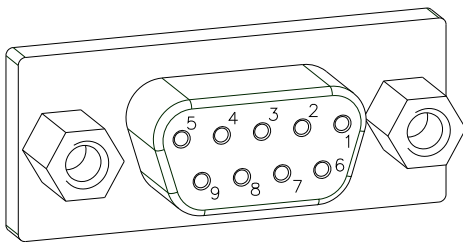
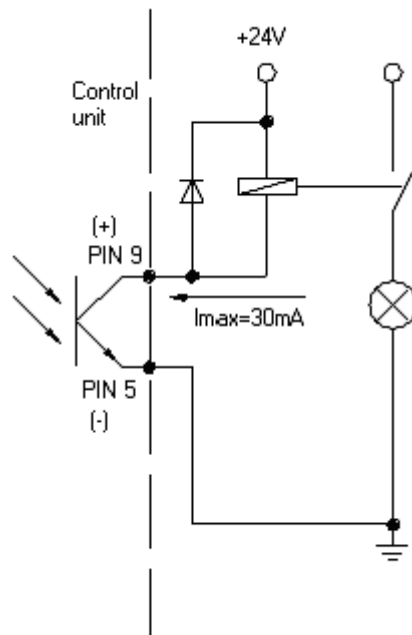

**Figure 14**

PIN (bushing)	Output I
	<b>Out 1: Error message</b> Each error status such as ribbon error is displayed.
	<b>Out 2: Print order</b> The print module was activated by a print order.
	<b>Out 3: Generation</b> The print module is filled with current layout data.
	<b>Out 4: Layout print</b> The content of print memory is transferred on the printable medium by means of the printhead.

**Example**

Connection of a lamp to a 24V relay by Out 1:



**Figure 15**

Output II  
Figure 13, C

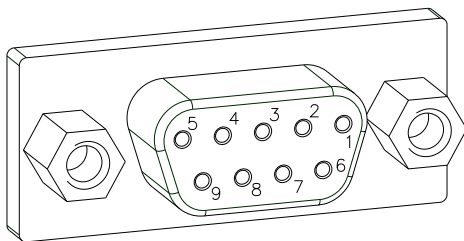

**Figure 16**

PIN (bushing)	Output II
<p>9 (+) 5 (-)</p>	<p>Out 5: Print-Ready signal</p> <p>It is indicated if the print module is ready to process a start impulse. In contrary to the print order signal, the generating time is taken into consideration.</p>
<p>8 (+) 7 (-)</p>	<p>Out 6: Printhead up</p> <p>The printhead has reached the upper rest position (e.g. return to zero point).</p>
<p>6 (+) 2 (-)</p>	<p>Out 7: Return to start</p> <p>After termination of print procedure the flexible part of the print module is moved back to the start position. After the start position was reached a new start can be released.</p>
<p>4 (+) 3 (-)</p>	<p>Out 8: Prior warning of transfer ribbon end</p>



**Control inputs**

By means of the control inputs it is possible to control printing. The control inputs at Input I are electroplated separated and have to be provided with an external tension source. The signal level is active "HIGH".

Input I  
Figure 13, B

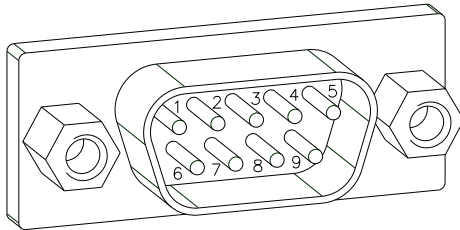
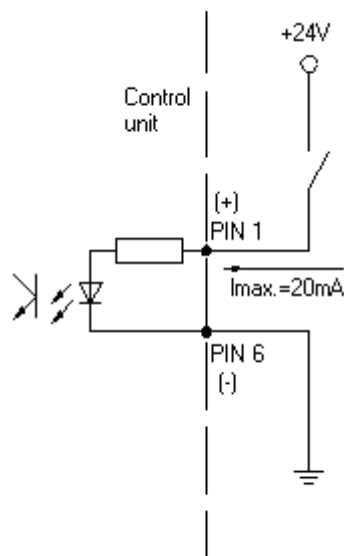

**Figure 17**

PIN (pin)	Input I
	In 1: Print start
	In 2: Not used
	In 3: Reset external counter
	In 4: Not used

**Example**

Connection of a switch with 24V voltage supply by In 1:



**Figure 18**

Input II  
Figure 13, D

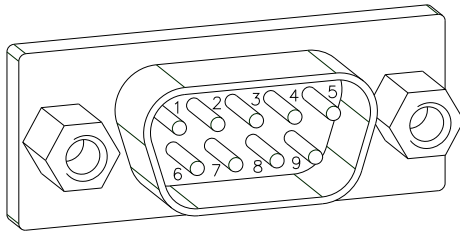

Figure 19

PIN (pin)	Input II
	In 5: Not used
	In 6: Not used
	In 7: Not used
	In 8: Not used

### 3.3 Plug & Play

Plug & Play capable printers can be recognised automatically at parallel ports, USB-IEEE 1394- or infra-red connections but the last both are not important for our direct print modules.

The following table shows the Plug & Play capability of the different operating systems.

Port		Windows					
		95	98	Me	NT4	2000	XP
LPT	Support	✓	✓	✓	✓	✓	✓
	Recognition by	Boot procedure, device manager			x	Installation	
USB	Support	x	✓	✓	s.b.	✓	✓
	Recognition by	x	Hot Plug & Play		s.b.	Hot Plug & Play	

The table above shows that USB provides the recognition during the connection in current operating mode, the so-called Hot-Plug & Play. The following possibilities exist for parallel port:

- Windows 95 / 98 / Me  
Printers are recognised during the start procedure by Windows or by the search for new hardware by means of the hardware wizard.
- Windows 2000 / XP  
Printers can be recognised during the start procedure by Windows or by the search for new hardware by means of the hardware wizard or, if the option 'Automatic recognition and installation of Plug & Play printers' is set in the printer installation wizard. For Windows XP the Hot Plug & Play when switching on the printer is obviously possible.



Windows NT 4.0 does not support USB devices. However, some distributors offer drivers that support USB (without Plug & Play). Such a driver which suits to our printer is offered from BSQUARE. For more information, visit their web side: [www.bsquare.com](http://www.bsquare.com) or contact

BSQUARE Headquarters (USA)  
888-820-4500  
[sales@bsquare.com](mailto:sales@bsquare.com)

BSQUARE (Europe)  
+49 (811) 600 59-0  
[europe@bsquare.com](mailto:europe@bsquare.com)

### 3.4 Pin assignment of encoder socket \*

5-pin connecting bushing, contacts according to DIN 45322

connector socket  
encoder

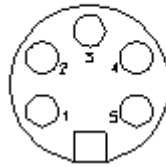

PIN1 = 5 VDC

PIN2 = Encoder signal (channel A)

PIN3 = Encoder signal (channel B)

PIN4 = GND

#### Electrical data of encoder

Operating voltage:	5 VDC
Output signal:	TTL level
Resolution:	Can be set at the print module

#### Connection of encoder

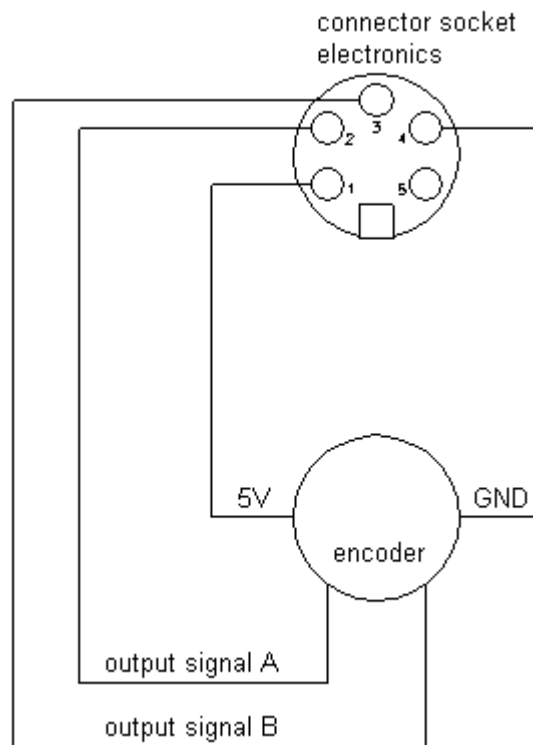

\* only for continuous mode

## 4 Installation and Initiation

### Unpack the direct print module

- ⇒ Lift the direct print module out of the box.
- ⇒ Check the direct print module for transport damages.
- ⇒ Check delivery for completeness.

### Scope of delivery

- Print mechanics.
- Control unit.
- Power cable.
- Connection cable (sensors, power).
- Mini controller.
- Manometer.
- Pneumatic tube.
- Push-on connector.
- I/O accessories (female connectors for I/O, I/O 24 cable).
- 1 transfer ribbon roll.
- Empty core, mounted on transfer ribbon rewinder.
- Cleaning foil for printhead.
- Documentation.
- CD with printer drivers.



Retain original packaging for subsequent transport.

## 4.1 Installation of print mechanics at machines

### Installation with mounting frame



The mounting frame is an option and therefore it is necessary to order it separately.

At the bottom of the print mechanics are two M8 threads that can be used to fasten the print mechanics.

Please observe the following conditions:

- The maximum thread engagement of the M8 threads is 10 mm.
- The print mechanics has to be installed with a distance from printhead to brake stator of 1...2,5 mm (see illustration).



A distance of 2 mm is recommended.

- The best print results can be received if the silicon of printing roll consists of a hardness of 40 - 50° Shore A (average value of roughness Ra 3.2 µm).
- The print surface has to be installed parallel to the linear movement of print unit and the focal line of printhead. Discrepancies to the focal line and cavities in the print surface of 0.2mm can lead to an inferior print quality at these positions.

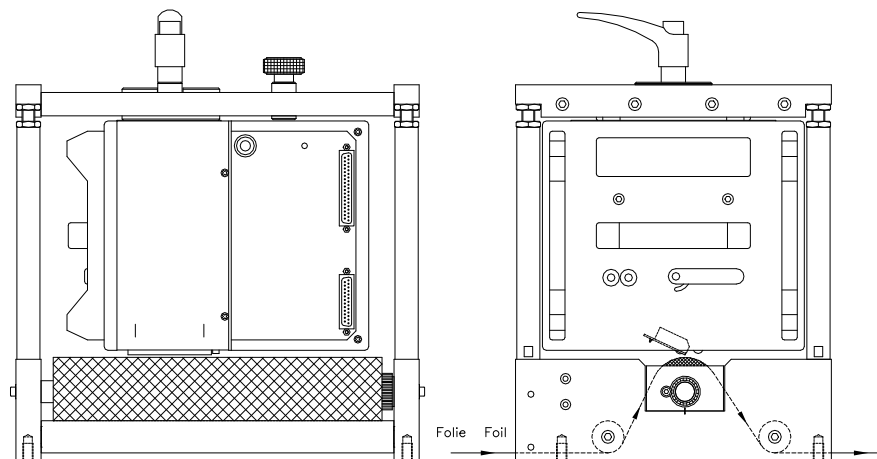

Figure 20

### Installation without mounting frame

In case the machine is used without mounting frame, then it is possible to fix the print module from the top with four M6 screws.

The maximum thread engagement of the M6 threads is 6 mm.

(position of printhead see illustration)

**Required space for outgoing cable unit - Standard**

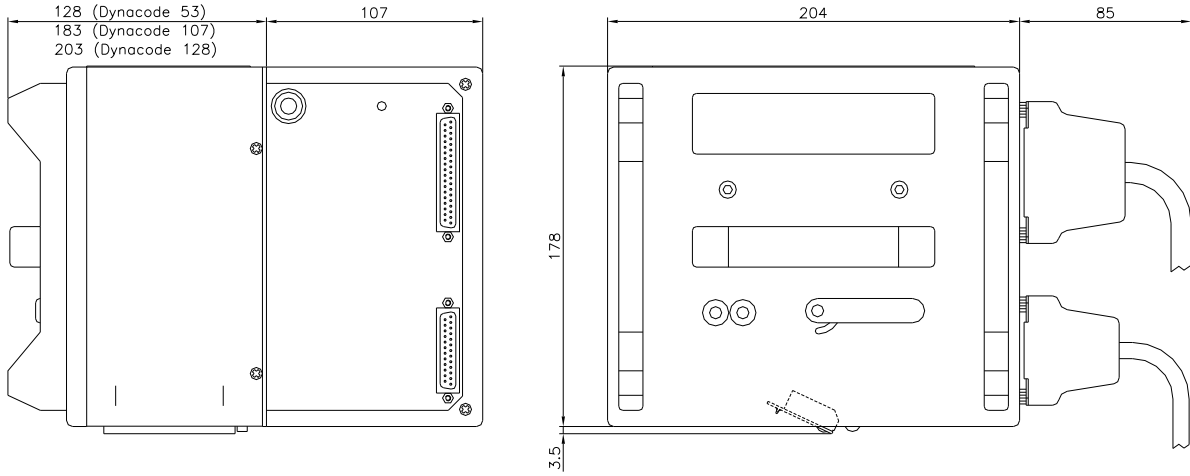

**Required space for outgoing cable unit - - behind (option)**

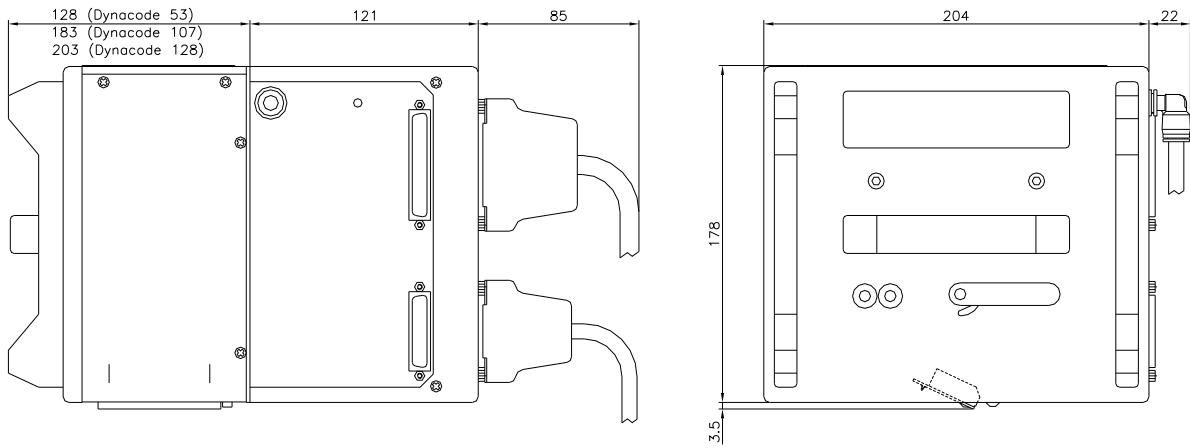

## 4.2 Connection of pneumatic power supply

The pneumatic power supply for the printhead mechanics has to be made available a minimum continuous pressure of 4 - 6 bars in front of the pressure regulator. The maximum pressure in front of the pressure regulator is 7 bars and 4 bars after the pressure regulator.



A pneumatic power supply of 4 bars is recommended.

The compressed-air has to be dry and oil free.

The supplied pressure regulator with manometer is to connect with a pneumatic tube  $\varnothing$  8 mm via a plugging bolting to the pneumatic power supply. It is necessary to make a connection between the pressure regulator and the print mechanics via a pneumatic tube  $\varnothing$  8 mm.

Please observe the following notes:

- Position pressure regulator as near as possible to the print mechanics.
- The pressure regulator is only to operate in the direction that is indicated on its underside. The direction shows the way of the streaming air.
- It is not allowed to bend the pneumatic tubes.
- Shortening of the pneumatic tubes has to be made with a clean right-angled cut without squashing the tube. If necessary use special tools (available in pneumatic requirements).
- Please observe a possible short length of the 8 mm pneumatic tubes.

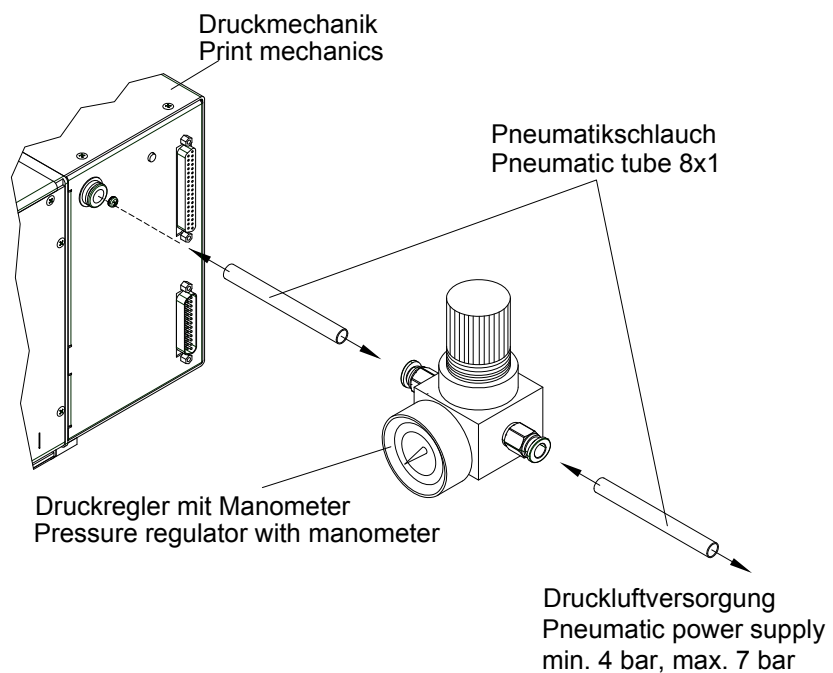
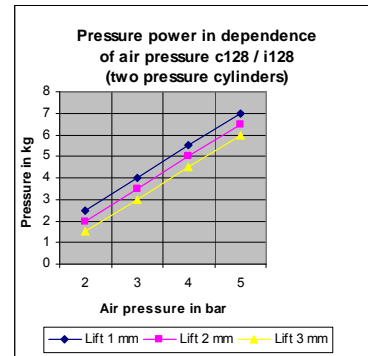
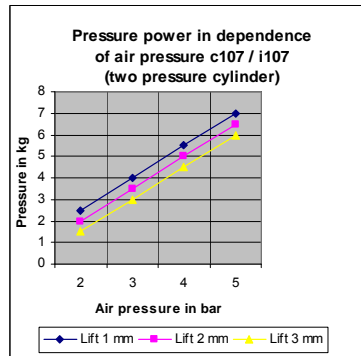
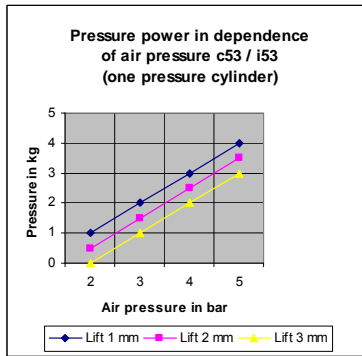

Figure 21



### 4.3 Adjustment of pressure power



The pressure power of the printhead can be set with the pressure regulator. The values are indicated in the following table:



In case the pressure power is set too low, it is possible that the printhead has no contact to the counter-pressure plate. Because of the missing heat during the print this could damage the printhead. In this case an error message appears. This error message is only to protect the printhead for overheating and is not to use as print quality control.

The lift indicates the distance between printhead and brake stator in 'print less' status.

	Dynacode 53	Dynacode 107	Dynacode 128
Recommended pressure power:	40 N	40 N	40 N
Max. pressure power:	45 N	45 N	45 N

As the mechanical wear and tear of the printhead increases with the pressure power, the pressure power should be as low as possible.

#### 4.4 Connecting the direct print module

##### Connecting to the power supply

The direct print module is equipped with a versatile power supply unit. The device may be operated with a mains voltage of 110-230 V / 50-60 Hz without any adjustments or modifications.



##### CAUTION!

The direct print module can be damaged by undefined switch-on currents.

⇒ Set the power switch to '0' before plugging in the direct print module.

⇒ Insert power cable into power connection socket.

⇒ Insert plug of power cable into a grounded electrical outlet.

##### Connecting to a computer or to a computer network



Insufficient or missing grounding can cause faults during operation.

Ensure that all computers and connection cables connected to the direct print module are grounded.

⇒ Connect direct print module to computer or network with a suitable cable.

#### 4.5 Before initial operation

- Mount print mechanics.
- Connect all cables between print mechanics and control unit.
- Protect cables against unintentional unscrewing.
- Connect compressed air line.
- Connect control unit and PC by printer interface.
- Connect control unit and packaging machine by inputs and outputs.
- Connect power cable of control unit.

## 4.6 Print control

Because of the fact that the print module is always in control mode it is only possible to transmit and not to start print orders by the available interfaces (serial, parallel, USB or Ethernet). The print is started by a start signal to the 'print start-control input'. It is necessary for the control unit to recognise the moment of setting the start signal and therefore it is possible and also necessary to observe the print status by the outputs.

## 4.7 Initiation

Once all connections have been made:

- ⇒ Switch control unit on with the power switch.  
After switching on the device the main menu appears which shows the model type, current date and time.
- ⇒ Insert ribbon cassette (see 5 on page 37).  
After loading the transfer ribbon cassette the measuring of transfer ribbon begins and the printhead is moved to the print position.



## 5 Loading ribbon cassette



Before a new transfer ribbon roll is loaded, the printhead must be cleaned using printhead and roller cleaner (97.20.002). For detailed information, please see page 75.

The handling instructions for the use of Isopropanol (IPA) must be observed. In the case of skin or eye contact, immediately wash off the fluid thoroughly with running water. If the irritation persists, consult a doctor. Ensure good ventilation.

### 5.1 Ribbon coating outside



As for the electrostatic unloading the thin coating of the thermal printhead or other electronic parts can be damaged, the transfer ribbon should be antistatic.

The use of wrong materials can lead to printer malfunctions and the guarantee can expire.

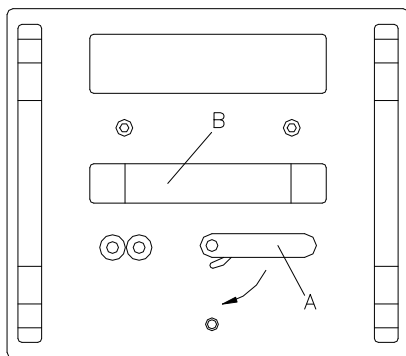

- Turn lever (A) 90° in clockwise direction.
- Remove ribbon cassette from print mechanics by pulling handle (B).
- Load a new ribbon roll as far as it will go onto unwinding roll (C).
- Load an empty cardboard roll as far as it will go onto rewinding unit (D).
- Insert ribbon according to illustration.
- Fix ribbon with an adhesive tape at the empty roll and tighten it by some turns of the core.
- Push ribbon cassette again onto print mechanics and take care that the ribbon not rip.
- Turn lever (A) 90° anticlockwise.

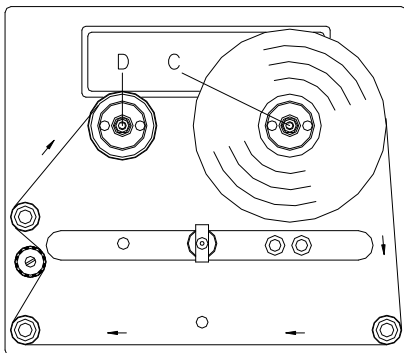

**Figure 22**

The above illustration shows a left hand printing system. If you are using a right hand system, then the new roll is to be inserted at the left and the cardboard core is to be inserted at the right side.

## 5.2 Ribbon coating inside



As for the electrostatic unloading the thin coating of the thermal printhead or other electronic parts can be damaged, the transfer ribbon should be antistatic.

The use of wrong materials can lead to printer malfunctions and the guarantee can expire.

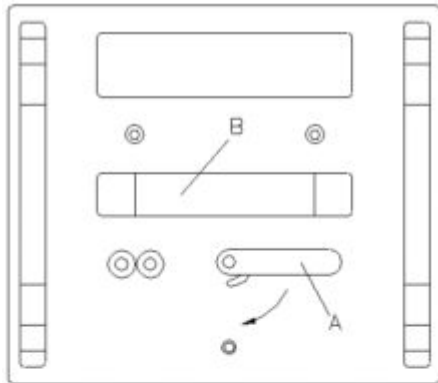

- Turn lever (A) 90° in clockwise direction.
- Remove ribbon cassette from print mechanics by pulling handle (B).
- Load a new ribbon roll as far as it will go onto unwinding roll (C).
- Load an empty cardboard roll as far as it will go onto rewinding unit (D).
- Insert ribbon according to illustration.
- Fix ribbon with an adhesive tape at the empty roll and tighten it by some turns of the core.
- Push ribbon cassette again onto print mechanics and take care that the ribbon not rip.
- Turn lever (A) 90° anticlockwise.

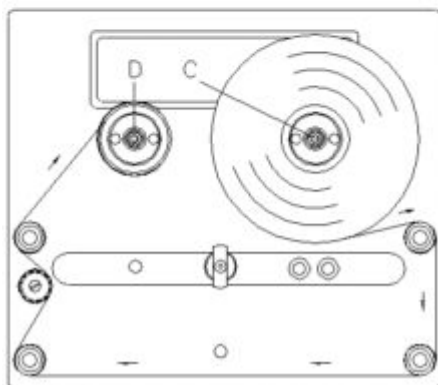

**Figure 23**

The above illustration shows a left hand printing system. If you are using a right hand system, then the new roll is to be inserted at the left and the cardboard core is to be inserted at the right side.

### 5.3 Increasing the clamping force for ribbon roll



We recommend the use of high-quality transfer ribbon with a cardboard core. A sample ribbon roll is included in the scope of delivery. The clamping force of transfer ribbon roll placed on the rewinding/unwinding unit is designed for this quality.

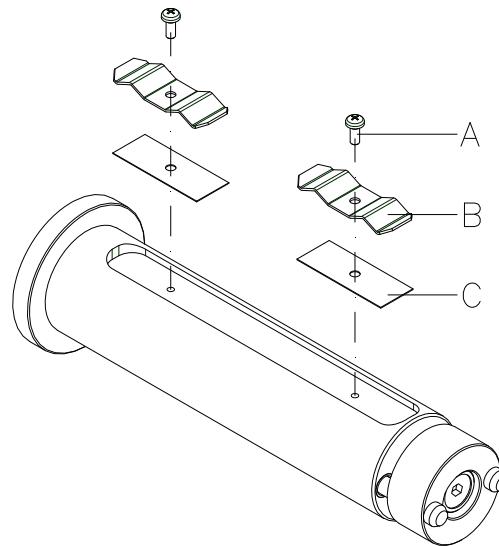

If other transfer ribbons are used, it can occur that the clamping force of the spring plates (B) is not sufficient, in order to position the rolls surely and to protect it against rotating.

When using transfer ribbons with plastic cores a safe positioning of the roles cannot be ensured.



#### CAUTION!

Slippage of transfer ribbon roll placed on the rewinding/unwind unit or the empty cardboard core leads to malfunctions.

⇒ When using transfer ribbon rolls with plastic cores the groove must be shimmed.

#### Increasing the clamping force

















- Remove screws (A) and spring plates (B).
- Insert shim (C, included in scope of delivery) into the groove.
- Fasten again spring plates (B) and shims (C) with screws (A).
- Insert transfer ribbon roll and empty cardboard core on the rewinding/unwinding unit.  
Check firm position!





## 6 Foil keyboard

### 6.1 Keyboard assignment (standard)

Key	Meaning	Function
	Main menu	Back to main menu. Activate test print. Delete stopped print order.
	Up	Printhead upwards.
	Down	Printhead downwards.
	Function menu	Change to function menu. In function menu, one menu item back.
	Feed	In main menu, one layout feed. In function menu, change to next menu item.
	Start/Stop	Confirm settings in function menu. Stop and continue current print order. Delete stopped print order with key  . No further layout of the print order is printed.
	Memory	Change to Compact Flash card menu.
	Quant	Change to number of copies menu. Press keys  and  to select the number of copies that are to print.
	Backwards	Change to previous input field. Press keys  and  to change values.
	Forwards	Change to next input field. Press keys  and  to change values.
0 - 9	Function keys	Parameter selection (e.g. speed).
F1 + F2	Function keys	No function.
<b>C</b>	Function key	Delete complete entry.
<b>E</b>	Function key	Confirm entry. After confirmation of settings, return to the main menu.

## 6.2 Keyboard assignment (text entry/customized)

The control unit of the print module is equipped with an alphanumeric character block which allows the user to enter parameters and customised variables without the connection of an external keyboard. Each key contains letters and similar to the use of a mobile phone (like sms) a direct and time-saving input is possible.

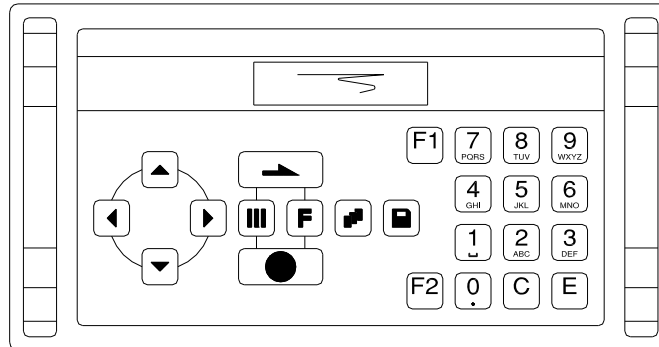

The mode is displayed in the first line at the right position so the user can control in which input mode is selected.

```
Article no.  0
1234_
```

```
Color code   M
AB_
```

As the input is almost done with characters from one mode, the characters are divided in different groups. Following input modes are available:

Symbol	Mode
0	Standard, starting with figures
M	Starting with capital letters
m	Starting with small letters
A	Input Alt
a	Input Alt, is switched off after one character

### Mode 0

This mode is displayed as default. At first the figure which corresponds to the key is displayed, then all capital and afterwards the small letters.

### Mode M

At first all capital, then the small letters and at last the corresponding figure.

### Mode m











At first all small letters, then the figure and at last the capital letters.

### Mode A

This mode can be used for the creation of special characters. The desired character can be displayed by the assigned number by entering the ANSI code. Please note that the ANSI code has to consist of three digits, i.e. you have possible to enter a zero first.

### Mode a

Same as mode A. After input of the selected ANSI code the machine, however, changes back to the previously selected input mode.

Key	Meaning	Function
	Main menu	Back to main menu. Activate test print. Delete stopped print order.
	Up	For customized variables, change between single entries.
	Down	For customized variables, change between single entries.
	Funktion menu	No function.
	Vorschub	Entry confirmation. Change to the main menu.
	Start/Stop	Confirmation/end of entry.
	Memory	Entry mode selection.
	Quant	Delete character at cursor position. If the cursor is behind the last character, the last one is deleted. Character is only deleted if it was before entered by the character block.
	Backwards	Cursor one position to the left.
	Forwards	Cursor one position to the right.
0 - 9	Character block	Entry of desired data.
F1 + F2	Function keys	No function.
<b>C</b>	Function key	Delete complete entry. The entry is only deleted if it was entered by the character block.
<b>E</b>	Function key	Confirm entry. After confirmation of settings, return to the main menu.



## 7 Function menu

### 7.1 Menu structure (continuous mode)

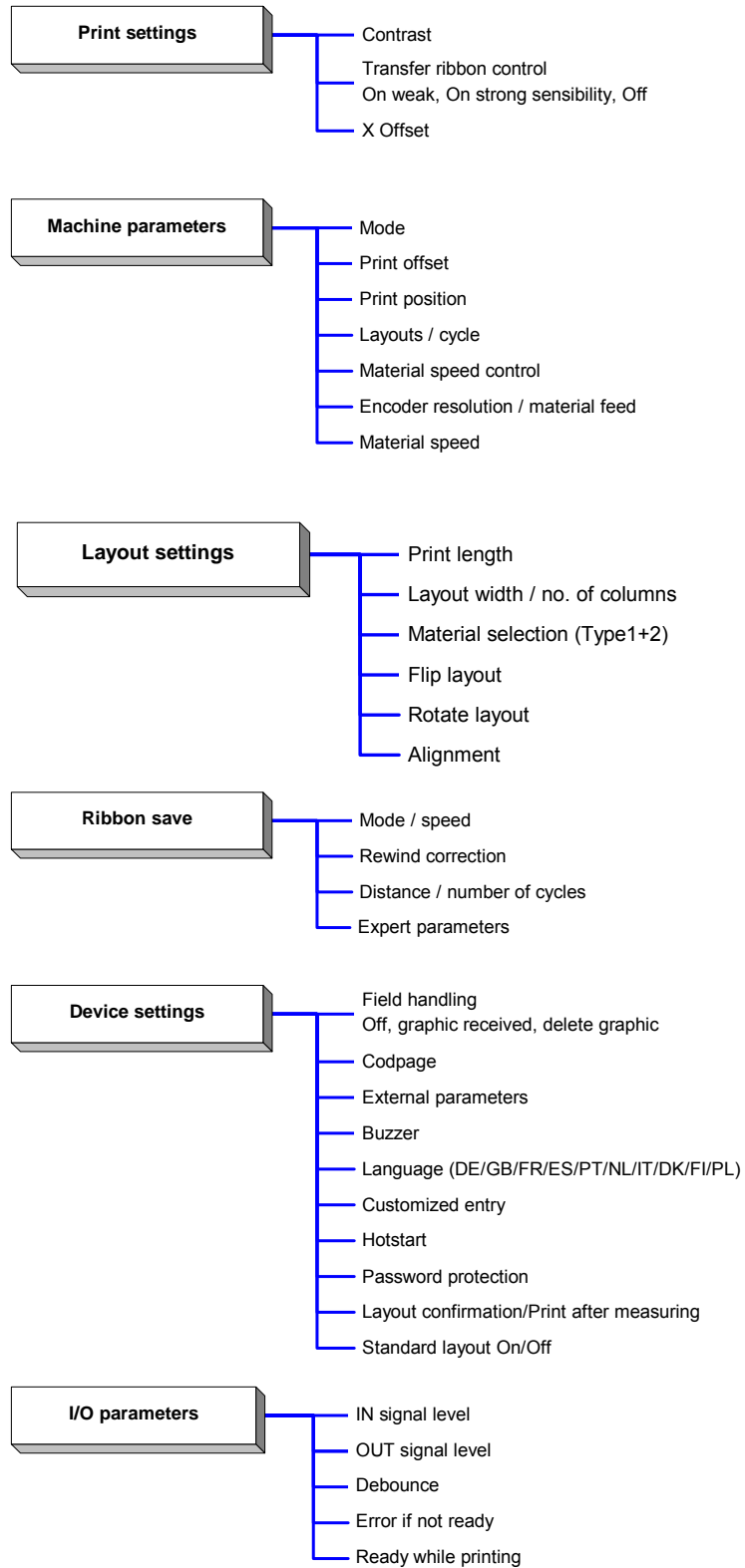

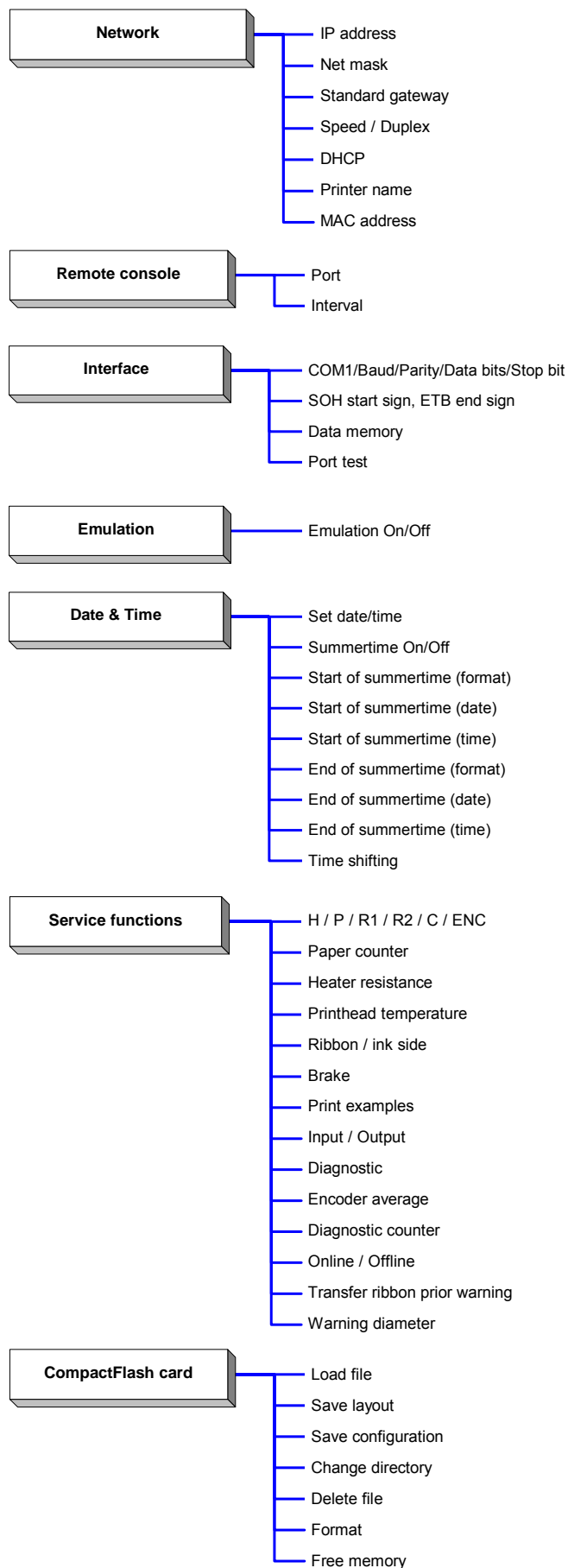

## 7.2 Menu structure (intermittent mode)

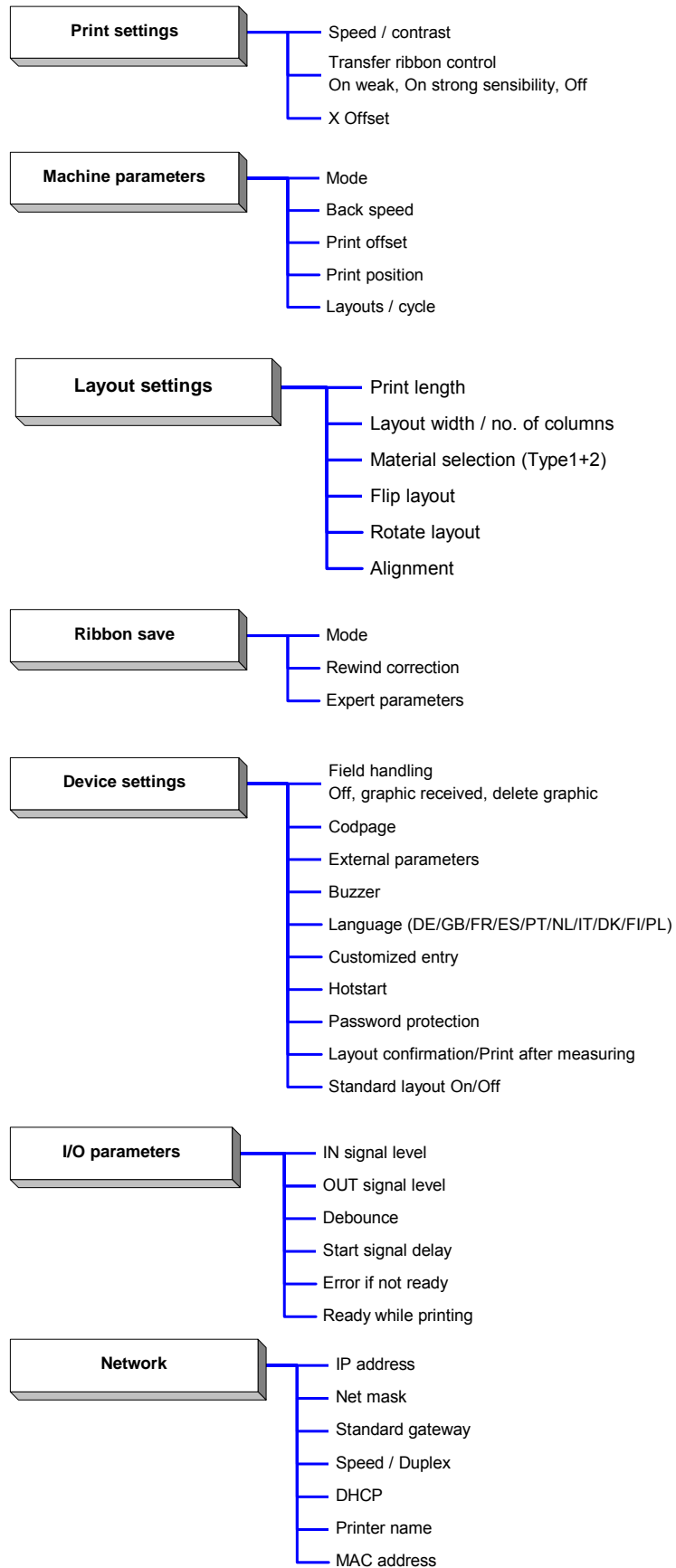

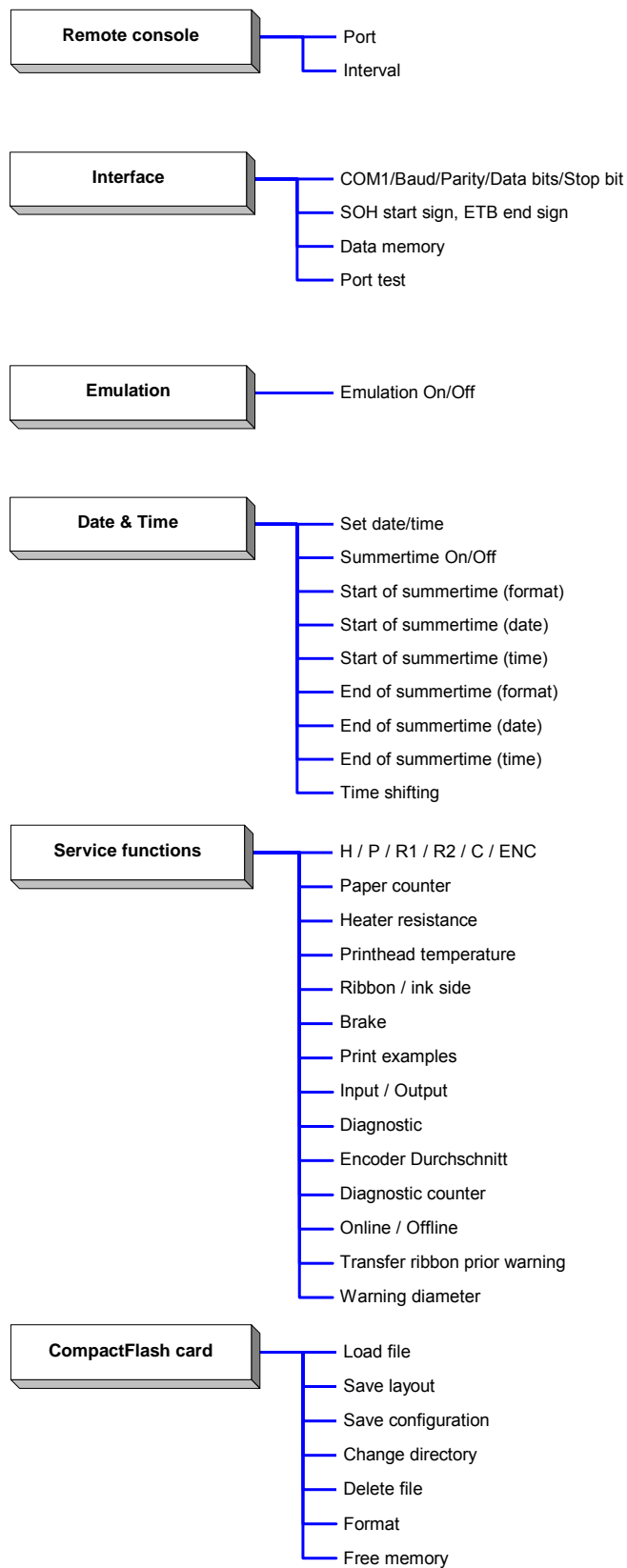



### 7.3 Print settings

Press key **F** to access the function menu.

Press key **●** to select the menu.

```
Function Menu
Print Settings
```

#### continuous mode

```
Contrast
(in %):      100
```

#### intermittent mode

```
Speed:      100
Contrast:   100
```

#### Speed:

Indication of speed in mm/s  
(see Technical data, page 17).

#### Contrast:

Indication of contrast in %.  
Value range: 10% to 200 %.  
Step size: 10%.

Press key **▶** to arrive at the next menu item.

```
Ribbon Control
ON strong sens.
```

#### Ribbon control:

Examination if the transfer ribbon roll is to end or if the ribbon was torn at the unwinding roll.

**Off:** The ribbon control is deselected, i.e. the direct print module continues without an error message.

**On:** The ribbon control is selected, i.e. the current print order is interrupted and an Error Message appears at the display.

**strong sensibility:** The direct print module reacts immediately to the end of the transfer ribbon.

**weak sensibility:** The direct print module reacts at approx. 1/3 more slowly to the end of the transfer ribbon.

Press key **▶** to arrive at the next menu item.

```
X Displacement
Offs (mm): -1.5
```

#### X displacement:

Indication of displacement in X direction. The fields on the layout are moved.

Value range: -90.0 ... +90.0.

## 7.4 Machine parameters (continuous mode)

Press key **F** to access the function menu.

Press key **▲** as long as you arrive at the 'Machine parameters' menu.

Function Menu  
Machine Param.

Press key **●** to select the menu.

Mode  
IO DY

### Mode:

It is not possible to start printing by the interface. The machine is always in control mode and the print is released by the control input 'print start'. The operating mode is normally transferred with each layout otherwise mode 'I/O dynamic continuous' is used as standard operating mode.

With keys **▲** and **▼** you have the possibility to select res. change the operating mode. At the moment the following modes are available:

### IO ST = IO static:

The input signal is evaluated, i.e. it is printed as long as the signal exists. The number of layouts, which was entered at print start, is printed (level evaluation of print start signal).

### IO ST F = IO static continuous:

Corresponds to IO static. Continuous means that not only a defined number of pieces is processed but the same layout is printed as long as new data is transferred by interface.

### IO DY = IO dynamic:

The external signal is evaluated dynamically, i.e. in case the direct print module is in 'waiting' mode a single layout is printed at each signal changing (flank evaluation of print start signal).

### IO DY F = IO dynamic continuous:

Corresponds to IO dynamic. Continuous means that not only a defined number of pieces is processed but the same layout is printed as long as new data is transferred by interface.

### Test mode:

This operating mode corresponds to mode 2. After the return of the print unit to the zero point of the machine, however, internally a further cycle is started (endurance test).

### Direct start:

A print order is transferred. After termination of generating process the print order is executed without an external signal.

Print Offset  
(mm) 10.0

Press key **▶** to arrive at the next menu item.

**Print offset:**

Indication of distance of the layout (res. the first layout in case more layouts per cycles are to be printed) to the zero point of machine.

Settings possible either in mm or ms. Place cursor at the mm and/or ms position, press key **▲** to change between mm and ms.

Value range: 1 ... 999 mm

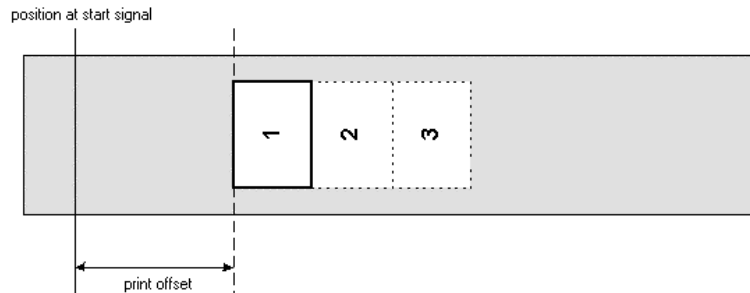

Print position  
(mm) 20.0

Press key **▶** to arrive at the next menu item.

**Print position:**

Indication of position of print carriage in mm.

Value range: 12 ... 93 mm

Press key **▶** to arrive at the next menu item.

Layouts/cycle  
1

**Layouts/cycle:**

Indication of number of printed layouts per print start (cycle).

Value range: 1 ... 25.

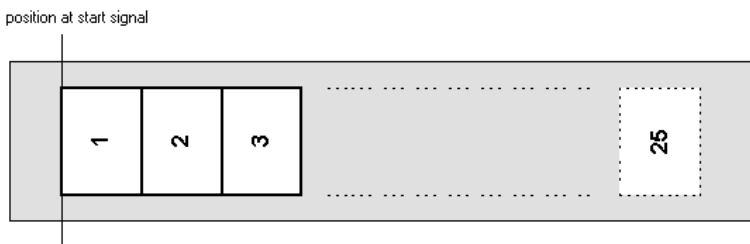

ChkSpeed On Strt  
Off

Press key **▶** to arrive at the next menu item.

**Check material speed at print start signal:**

**Off (Default):** Material speed is only checked if the set offset value is taken into consideration. It is possible to activate print start signal although the material is not yet in move. However, until the end the material speed has to be inside the valid speed sector as otherwise the print order is cancelled.

**On:** Material speed is checked at print start signal. Is the material speed outside of the valid speed sector then the start signal is ignored.

Press key **▶** to arrive at the next menu item.

Res. mm/360°  
2000 166

**Encoder resolution / material feed per encoder rotation:**

This function indicates resolution of used encoder and material feed per rotation of encoder in mm. These settings help measuring the material speed.

The material feeding per encoder rotation corresponds for instance, in a 1:1 translation between the encoder and the roller, to the roller circumference.

Press key **▶** to arrive at the next menu item.

Material speed  
200 mm/s

**Material speed:**

Indication of material speed (only for reading purposes).

## 7.5 Machine parameters (intermittent mode)

Press key **F** to access the function menu.

Press key **▶** as long as you arrive at the 'Machine parameters' menu.

Function Menu  
Machine Param.

Press key **●** to select the menu.

Mode  
2 continuous

### Mode:

Selection of operating mode.

### Mode 1 = Single item processing:

A print order with a defined number of pieces is transferred. After the generating process the target number and the actual number of pieces is shown in the display. A cycle is started via signal input 1 or with key **▶**. With each cycle the actual number of pieces is increased by the number of printed layouts. In case the target number of pieces is reached the print order is finished and the display shows again the main menu.

### Mode 2 = Continuous mode:

A print order is transferred. After the generating process the number of printed layouts is shown in the display. A cycle is started via signal input 1 or with key **▶**. With each cycle the number of printed layouts is increased. The print order is active as long as it is terminated by the user or in case of new data transmission.

### Mode 3 = Test mode:

This operating mode corresponds to mode 2. After the return of the print unit to the zero point of the machine, however, internally a further cycle is started (endurance test).

### Mode 4 = Direct start:

A print order is transferred. After termination of generating process the print order is executed without an external signal.

Press key **▶** to arrive at the next menu item.

Back-Speed mm/s  
400

### Back-Speed:

Indication of back speed of the print mechanics after print end in mm/s.

Each cycle of the machine consists of printing and return to the zero point of machine. It is possible to set the print speed and back speed separately. The setting range for the back speed is between 50 and 600 mm/s.

Because of this value you can select for low machine clock cycles an operating method which saves the material and increases in this way the life of the printhead.

Because of the mass moment of inertia it could be better to reduce the speed at an installation position of the print unit at >30° horizontal.

Value range: 50 ... 600 mm/s.

Print Offset  
(mm) 10.0

Press key  to arrive at the next menu item.

**Print offset:**

Indication of distance of the layout (res. the first layout in case more layouts per cycles are to be printed) to the zero point of machine.

Value range: 0 ... 93 mm

Default: 0 mm

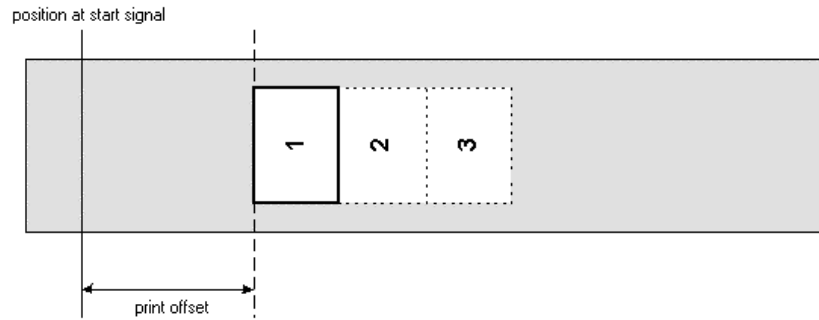

Print position  
(mm) 20.0

Press key  to arrive at the next menu item.

**Print position:**

Indication of start position of print carriage in mm.

Value range: 0 ... 93 mm

Default: 83 mm

Press key  to arrive at the next menu item.

Layouts/cycle  
1

**Layouts/cycle:**

Indication of the number of printed layouts per print start (cycle).

Value range: 1 ... 25.

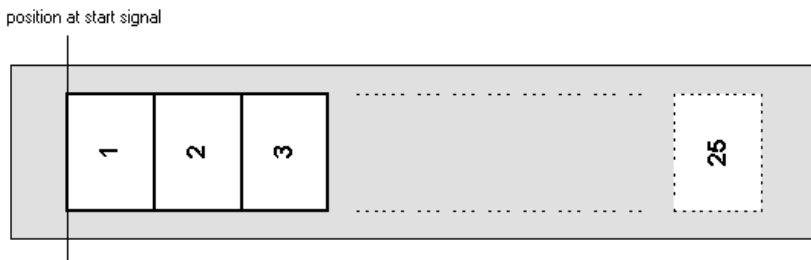

## 7.6 Layout settings

Press key **F** to access the function menu.

Press key **▶** as long as you arrive at the 'Layout settings' menu.

Press key **●** to select the menu.

Function menu  
Layout settings

Print length (mm)  
120.0

### Print length:

Indication of way which the print mechanics has to move. The print length depends on the length of the print mechanics.

Press key **▶** to arrive at the next menu item.

Width: 20.0  
Columns: 4

### Column printing:

Indication of width of one layout as well as how many layouts are placed side by side (see chapter 12.1 Column printing, on page 97).

Taste **▶** to arrive at the next menu item.

Material  
Type 2

### Material selection:

Selection of the used print media..

Press key **▶** to arrive at the next menu item.

Flip layout  
Off

### Flip layout:

The axis of reflection is in the middle of the layout. If the layout width was not transferred to the module, automatically the default layout width i.e. the width of the printhead is used. Because of this reason you have to note that the layout should have the same width as the printhead as otherwise this could lead to problems in positioning.

Press key **▶** to arrive at the next menu item.

Rotate layout  
On

### Rotate layout:

As default the layout is printed with 0° head forward. In case of an activated function, the layout is rotated by 180° and it is printed in reading direction.

Press key **▶** to arrive at the next menu item.

Alignment  
Left

### Alignment:

The adjustment of layout is effected only after 'flip/rotate label', i.e. the adjustment is independent of the functions flip and rotate layout.

**Left:** The layout is aligned at the left-most position of printhead.

**Centre:** The layout is aligned at central point of printhead.

**Right:** The layout is aligned at right-most position of printhead.

## 7.7 Ribbon save (continuous mode)

Press key **F** to access the function menu.

Press key **▲** as long as you arrive at the 'Ribbon save' menu.

Press key **●** to select the menu.

Press key **▼** and **▲** to select the desired ribbon save mode.

```
Function Menu
Ribbon Save
```

```
Mode      Speed
Standard  600
```

### Mode:

Selection of ribbon save mode.

- **Off:** Ribbon save mode Off.
- **Standard:** Maximum ribbon save performance, i.e. with this setting there is no loss of transfer ribbon (apart from the safety distance of 1 mm, so the print fields are not printed one into the other).  
No settings are allowed with which the ribbon save no more cannot be achieved. This particularly applies for the print offset, which can only be adjusted now in the valid range (see chapter 13.2, page 102).
- **Shift:** Label data can be printed several times laterally displaced. A maximum utilization of transfer ribbon can be achieved (see chapter 13.3, page 105).
- **SaveStrt:** No start signal loss, direct print module regulates the ribbon save quality automatically according to requirement. Automatic layout ribbon save and field ribbon save, each without feedback (see chapter 13.4, page 108).

### Speed:

Determination of max. print speed.

On the base of this value all necessary calculations e.g. feedback distance and smallest possible print offset are being calculated.

### Example:

Speed = 400                      Very good ribbon save result between  
Mode = Standard                50 mm/s and 400 mm/s.

However, if you print with a speed higher than 400 mm/s, then the ribbon save result is decreased and/or the ribbon save can no longer be executed, because the back-feed way was designed to 400 mm/s. Please consider: if speed is set to 400 and only 300 mm/s are printed, then a smaller number of cycles is reached as if speed is set to 300, however a reserve of 100 mm/s is still available.

Therefore the speed value should be always set to the maximum print speed. If the number of cycles is not sufficient, the rewind correction should be applied.

## 7.8 Ribbon save (intermittent mode)

Press key **F** to access the function menu.

Press key **▶** as long as you arrive at the 'Ribbon save' menu.

Press key **●** to select the menu.

Press key **▼** and **▲** to select the desired ribbon save mode.

Function Menu  
Ribbon Save

Mode  
Standard

### Mode:

Selection of ribbon save mode.

- **Off:** Optimierung aus.
- **Standard:** Maximum ribbon save performance, i.e. with this setting there is no loss of transfer ribbon (apart from the safety distance of 1 mm, so the print fields are not printed one into the other).  
No settings are allowed with which the ribbon save no more cannot be achieved. This particularly applies for the print offset, which can only be adjusted now in the valid range (see chapter 13.5, page 109).
- **Shift:** Label data can be printed several times laterally displaced. A maximum utilisation of transfer ribbon can be achieved (see chapter 13.6, page 110).



## 7.9 Device settings

Press key **F** to access the function menu.

Press key **▶** as long as you arrive at the 'Device settings' menu.

Press key **●** to select the menu.

Function Menu  
Device Settings

Field Handling  
OFF

### Field handling:

**Off:** The complete print memory is deleted.

**Keep graphic:** A graphic res. a TrueType font is transferred to the direct print module once and stored in the direct print module internal memory. For the following print order only the modified data is transferred to the direct print module. The advantage is the saving of transmitting time for the graphic data.

The graphic data created by the direct print module itself (internal fonts, bar codes, ...) is generated only if they were changed. The generating time is saved.

**Delete graphic:** The graphics res. TrueType fonts stored in the internal memory is deleted but the other fields are kept.

Press key **▶** to arrive at the next menu item.

Codepage  
ANSI charset

### Codepage:

Indication of the font used in the direct print module.

The following possibilities are available:

ANSI character set / Codepage 437 / Codepage 850 / GEM German / GEM English / GEM French / GEM Swedish / GEM Danish.

Press key **▶** to arrive at the next menu item.

ext. Parameters  
ON

### External parameters:

**Layout dimension only:** The parameters for layout length, gap length and layout width can be transferred to the printing system. All other parameter settings are to be made directly at the printing system.

**On:** Sending parameters such as print speed and contrast via our creation software to the printing system. Parameters which are set directly at the printing system before are no longer considered.

**Off:** Only settings made directly at the printing system are considered.

Press key **▶** to arrive at the next menu item.

Buzzer  
On

### Buzzer:

An acoustic signal is audible when pressing a key.

Value range: 1 ... 7.

**Off:** No signal is audible.

Press key **▶** to arrive at the next menu item.

Language  
English

### Language:

Selection of language in which you want to display the text in the display.

At the moment the following languages are available: German, English, French, Spanish, Portuguese, Dutch, Italian, Danish, Finnish, Polish, Czech and Russian.

Customized Entry  
On

Press key  to arrive at the next menu item.

**Customized entry:**

**On:** The question referring the customized variable appears once before the print start at the display.

**Auto:** The question referring the customized variable appears after every printed layout.

**Off:** No question appears at the display. In this case the stored default value is printed.

Press key  to arrive at the next menu item.

Hotstart  
Off

**Hotstart:**

**On:** Continue an interrupted print order after switching on the direct print module anew.

**Off:** After switching off the direct print module the complete data is lost (see chapter 12.3, on page 100).

Press key  to arrive at the next menu item.

Password Prot.  
Active

**Password:**

By a password several functions can be blocked, so the user cannot work with them. There are several applications in which the use of password protection makes sense (see chapter 12.2 Password, on page 98).

Press key  to arrive at the next menu item.

Layout P/Me Conf  
On Off

**Layout confirmation:**

**On:** A new print order is only printed after confirmation at the device. An already active continuing print order is printed as long as the confirmation is effected at the device.

**Off:** No query appears at the display of control unit.

**P/Me (print after measuring):**

**On:** If an error occurred during printing, whose removal can be recognized by the module (e.g. transfer ribbon end, cassette open), then the module changes after the error correction (e.g. cassette closed again) immediately in the 'ready' mode.

**Off:** After removal and confirmation of error, the module changes into 'stopped' mode.

Press key  to arrive at the next menu item.

Standard layout  
Off

**Standard layout:**

**On:** If a print order is started without previous definition of layout, the standard label is printed.

```

  POS 108/12 R
  V1.50 (Build 0001 )

  NO LABEL DATA
  
```

**Off:** If a print order is started without previous definition of layout, an error message appears in the display.

### 7.10 I/O parameters

Press key **F** to access the function menu.  
 Press key **▶** as long as you arrive at the 'I/O parameters' menu.  
 Press key **●** to select the menu.

Function Menu  
I/O Parameter

IN signal level  
1s2x3+4x5x6x7x8x

**IN signal level:**  
 Indication of signal at which a print order is started.  
 + = active signal level is 'high' (1)  
 - = active signal level is 'low' (0)  
 x = not activated signal level  
 s = status can be affected by interface\*

The modification of the signal level is only taken into consideration for the operating modes I/O static, I/O dynamic, I/O static continuous and I/O dynamic continuous.

Press key **▶** to arrive at the next menu item.

OUT signal level  
1+2+3+4+5+6+7+8+

**OUT signal level:**  
 Indication of signal level for output signal.  
 + = active signal level is 'high' (1)  
 - = active signal level is 'low' (0)  
 s = status can be affected by interface\*

Press key **▶** to arrive at the next menu item.

Debounce (ms)  
50

**Debounce:**  
 Indication of debounce time of the dispenser input. The setting range of the debounce time is between 0 and 100 ms.  
 In case the start signal is not clear then you can debounce the input by means of this menu item.

Press key **▶** to arrive at the next menu item.

Start delay (s)  
1.00

**Start signal delay:**  
 Indication in time per second of the delay for the start signal.  
 Value range: 0.00 ... 9.99.

Press key **▶** to arrive at the next menu item.

ErrorIfNotReady  
On

**Error if not ready:**  
**On:** If a print order is active but the direct print module is not ready to process the order (e.g. if it is already in 'printing' mode), then an error message appears.  
**Off:** No error message appears.

Press key **▶** to arrive at the next menu item.

ReadyWhilePrint  
Off

**Ready while printing:**  
 Indication if the output signal 'print ready' (Out 5, Output II) remains active while printing.  
**Off:** At print start the 'print ready' signal is inactive (default setting).  
**On:** At print start the 'print ready' signal remains active.

\* in combination with Netstar PLUS

### 7.11 Network

Press key **F** to access the function menu.

Press key **▲** as long as you arrive at the network menu.

Function Menu  
Network

For more information, please see the separate manual.

### 7.12 Remote console

Press key **F** to access the function menu.

Press key **▲** as long as you arrive at the 'Remote console' menu.

Function Menu  
Remote Console

For more information please contact our sales department.

### 7.13 Interface

Press key **F** to access the function menu.

Press key **▲** as long as you arrive at the 'Interface' menu.

Press key **●** to select the menu.

```
Function Menu
Interface
```

```
COM1 Baud  P D S
0      9600 N 8 2
```

#### COM1:

0 - serial interface Off.

1 - serial interface On.

2 - serial Interface On, no error message occurs in case of a transmission error.

#### Baud rate:

Indication of bits which are transferred per second.

Following values are possible: 1200, 2400, 4800, 9600, 19200, 38400 and 115200.

#### P = Parity:

N - No parity; E - Even; O - Odd

Please observe that the settings correspond to those of the direct print module.

#### D = Data bits

Setting of data bits.

Value range: 7 or 8 Bits.

#### S = Stop bits

Indication of stop bits between bytes.

Value range: 1 or 2 stop bits.

Press key **▲** to arrive at the next menu item.

**SOH:** Start of data transfer block → Hex format 01

**ETB:** End of data transfer block → Hex format 17

Two different start / end signs can be set. The settings are normally SOH = 01 HEX and ETB = 17 HEX. Several host computers cannot process these signs and therefore SOH = 5E HEX and ETB = 5F cannot be set.

Press key **▲** to arrive at the next menu item.

#### Data memory:

**Standard:** After starting a print order the direct print module buffer receives data as long as it is filled.

**Advanced:** During a current print order data is received and processed.

**Off:** After starting a print order no more data is received.

Press key **▲** to arrive at the next menu item.

#### Porttest:

Check whether the data are transferred via the interface.

Press the **▲** and **▼** keys to select standard (on). Press the **●** key and the data sent via any port (COM1, LPT, USB, TCP/IP) is printed.

```
Start (SOH): 01
End   (ETB): 17
```

```
Data Memory
Standard
```

```
Port test      Off
```

## 7.14 Emulation

Press key **F** to access the function menu.

Press key  as long as you arrive at the 'Emulation' menu.

Press key  to select the menu.

Function menu  
Emulation

Protocol  
ZPL

### Protocol:

**CVPL:** Carl Valentin Programming Language

**ZPL:** Zebra® Programming Language

Change between CVPL protocol and ZPL II® protocol.

Press key  to confirm the selection.

The printer performs a restart and ZPL II® commands are transformed into CVPL commands internally by the printer and then executed by the printer.

Press key  in menu protocol to arrive at the next menu item.

Head Resolution  
11.8 (Dot/mm)

### Printhead resolution:

At activated ZPL II® emulation the printhead resolution of the emulated printer must be set, e.g. 11.8 Dot/mm (= 300 dpi).



If the printhead resolution of the Zebra® printer differs from that of the Valentin printer, then the size of objects (e.g. texts, graphics) complies not exactly.

Press key  to arrive at the next menu item.

Drive mapping  
B:->A: R:->R:

### Drive mapping:

The access to Zebra® drives

B: Memory Card

R: RAM Disk (standard drive, if not indicated)

is rerouted to the corresponding Valentin drives

A: Memory Card (slot 1) and/or Compact Flash

B: Memory Card (slot 2)

R: RAM Disk

This can be necessary if the available space on the RAM disk (at present. 512 KByte) is not sufficient or if bitmap fonts are downloaded to the printer and be stored permanently.



As the printer built-in fonts in Zebra® printers are not available in Valentin printers, this can cause small differences in the text image.

## 7.15 Date & time

Press key **F** to access the function menu.

Press key **▶** as long as you arrive at the 'Date/time' menu.

Press key **●** to select the menu.

```
Function menu
Date/Time
```

```
Date    17.11.04
Time    13:28:06
```

```
Summertime
On
```

```
ST start format
WW/WD/MM
```

```
WW    WD    MM
last  sunday 03
```

```
ST start time
02:00
```

```
ST end format
WW/WD/MM
```

```
WW    WD    MM
last  sunday 10
```

```
ST end time
03:00
```

```
Time shifting
01:00
```

### Set date and time:

The upper line of display shows the current date, the second line the current time.

With keys **◀** and **▶** you can change to the next or previous field. With keys **▲** and **▼** you can increase and/or decrease the displayed values.

Press key **▶** to arrive at the next menu item.

### Summertime:

**On:** Direct print module automatically adjust clock for daylight saving changes.

**Off:** Summertime is not automatically recognized and adjusted.

Press key **▶** to arrive at the next menu item.

### Start of summertime (format):

Select the format in which you want to define beginning summertime. The above example indicates the default setting (European format).

DD = day; WW = week; WD = weekday; MM = month; YY = year; next day = only the next day is taken into consideration

Press key **▶** to arrive at the next menu item.

### Start of summertime (date):

By means of this function you can enter the date at which summertime has to start. This entry refers to the previously selected format.

Example: summertime is automatically adjusted at last Sunday in March (03).

Press key **▶** to arrive at the next menu item.

### Start of summertime (time):

By means of this function you can define the time when you want to start summertime.

Press key **▶** to arrive at the next menu item.

### End of summertime (format):

Select the format in which you want to define end of summertime.

The above example indicates the default setting (European format).

Press key **▶** to arrive at the next menu item.

### End of summertime (date):

By means of this function you can define the date when you want to stop summertime. The entry refers to the previously selected format.

Example: summertime is automatically adjusted at last Sunday in October (10).

Press key **▶** to arrive at the next menu item.

### End of summertime (time):

By means of this function you can define the time when you want to stop summertime.

Press key **▶** to arrive at the next menu item.

### Time shifting:

By means of this function you can enter time shifting in hours and minutes (for automatically adjustment from summer and wintertime).

This entry refers to the currently set direct print module time.

## 7.16 Service functions



In order that the distributor res. the manufacturer can provide fast support in case of malfunction, the direct print module is equipped with the Service functions menu.

Necessary information such as set parameters is indicated directly at the direct print module.

More information such as firmware or font version is shown in main menu (see chapter 7.17 on page 67).

Press key **F** to access the function menu.

Press key  as long as you arrive at the 'Service functions' menu.

Press key  to select the menu.

```
Function Menu
Service Function
```

```
H P R1 R2 C ENC
0 1 1 0 0 0
```

### Photocell parameters:

**H** = cover switch.

0 = open cover; 1 = closed cover.

**P** = compressed air control

Value range: 0 or 1.

**R1** = transfer ribbon rewinding roll

Indication of transfer ribbon rewinding roll status.

4 states are indicated (no marking in photocell, marking from right, marking from left, marking completely in photocell).

**R2** = transfer ribbon unwinding roll

Indication of transfer ribbon unwinding roll status.

4 states are indicated (no marking in photocell, marking from right, marking from left, marking completely in photocell).

**C** = Carriage

Indication of print carriage position.

**ENC** = Encoder

Indication of current state of encoder

Press key  to arrive at the next menu item.

### Paper counter:

**D**: Indication of printhead attainment in meters.

**G**: Indication of direct print module attainment in meters.

Press key  to arrive at the next menu item.

### Heater resistance:

To achieve a high print quality, the indicated Ohm value must be set after an exchange of printhead.

Press key  to arrive at the next menu item.

### Printhead temperature:

Indication of printhead temperature. The printhead temperature corresponds normally to the room temperature. In case the maximum printhead temperature is exceeded, the current print order is interrupted and an error message appears at the direct print module display.

Press key  to arrive at the next menu item.

### Ribbon / Ink side:

**Ribbon**: Selection of the used transfer ribbon length (300 m, 450 m, 600 m, 900 m or 1000 m). With smaller ribbons, a higher number of cycles can be reached.

### Ink side:

Selection of the coating side of transfer ribbon, either outside or inside.

Default: Coating outside

```
Paper Counter
D000007 G000017
```

```
Heater Resist.
1250
```

```
Ribbon Ink Side
600 m Out
```



```
BrkPow BrkPowP
100 % 100 %
```

Press key  to arrive at the next menu item.

**BrkPow:**

Adjustment of brake power for acceleration and braking in %.

**BrkPowP:**

Adjustment of brake power during printing.

Press key  to arrive at the next menu item.

```
Print Examples
Settings
```

**Print examples:**

**Settings:** Printout of all settings such as speed, and transfer ribbon material.

**Bar codes:** Printout of all available bar code types.

**Fonts:** Printout of all available font types.

Press key  to arrive at the next menu item.

```
Input: 11111111
Output: 00000000
```

**Input/Output:**

Indication of signal level which indicates the signal a print order is started.

0 - Low; 1 - High

Press key  to arrive at the next menu item.

```
Diagnostic
Enter
```

**Diagnostic:**

Press key  to access the diagnostic menu.

```
EncProf NoOfProf
Off 10
```

**Encoder Profiling:**

The encoder values with print start in logging files are registered on CF card. By means of this data, a graphic chart of the encoder curve can be created.

For further information please contact our support department.

Press key  to arrive at the next menu item.

```
DiaRU DiaRW
68mm 655mm
```

**Diameter of transfer ribbon rolls:**

**DiaRW** = Diameter of transfer ribbon rewinding roll.

**DiaRU** = Diameter of transfer ribbon unwinding roll.

Press key  to arrive at the next menu item.

```
Enc. Average
100
```

**Encoder average:**

Number of values by which the encoder signals is averaged. The more higher the value the more slowly react the device to speed modifications.

Press key  to arrive at the next menu item.

```
IgnrStrt IntPrts
123 456
```

**Diagnostic - Counter:**

Relevant results are counted and registered in RAM memory. The protocols get lost after switching off the device.

**IgnrStrt** = Counter for ignored start signals.

**IntPrts** = Counter for cancelled print orders.

```
Njb  Nrd  Prt
+000 +999 +999
```

Select with the cursor the value for which you need more information and then press key ●.

**NJb** = No job

Counter for ignored start signals because the print order was not active.

**NRd** = Not ready

Counter for ignored start signals because the print order was not ready (stopped or error message).

**Prt** = Printing

Counter for ignored start signals, during the device prints/is active.

```
MS/I ItfI SpdS
+000 +999 +999
```

**MS/I** = Manual stopped/interrupted

Stop key onto foil keyboard, panel or in a program was pressed.

**ItfI** = Interface interrupted

The print order was cancelled because new data was received by an interface.

**SpdS** = Speed stopped

The print order was cancelled because the measured print speed was too slow.

Press key ▲ to arrive at the next menu item.

```
Online/Offline
Off
```

**Online/Offline:**

This function is activated e.g. if the transfer ribbon is to be changed. It is avoided that a print order is processed although the module is not ready. If the function is activated then press the key ● to change between Online and Offline mode. The respective state is indicated in the display.

Standard: Off

**Online:** Data can be received by interface. The keys of the foil keyboard are only active, if you changed in the Offline mode with key ●.

**Offline:** The keys of the foil keyboard are still active but received data are not processed. If the module is again in Online mode then new print orders can be again received.

Press key ▲ to arrive at the next menu item.

```
TR advance warn.
On  ø: 40 v: 100
```

**TRB = Transfer ribbon advance warning:**

Before the end of transfer ribbon, a signal is send by the control output.

**Warning diameter:**

Setting of transfer ribbon advance warning diameter.

In case you enter a value in mm then a signal appears via control output when reaching this diameter (measured at transfer ribbon roll).

**v = Reduced print speed:**

Setting of the reduced print speed. This can be set in the limits of the normal print speed. Additionally there are the following settings:

-: No reduced print speed

0: Printer stops at reaching the warning diameter and indicates 'ribbon error'.

## 7.17 Main menu

After switching on the direct print module the display shows the following:

```
* DC c107-12K *
14/09/05 10:16
```

The first line of main menu indicates used device type.  
The second line indicates current date and time.

Press key  and the display shows the following:

```
* DC c107-12K *
V1.44
```

The second line of display indicates version number of firmware.  
After a short time the indication of display returns automatically to main menu.

Press again key  and the display shows the following:

```
* DC c107-12K *
Build 0201
```

Indication of software Build version.

Press again key  and the display shows the following:

```
* DC c107-12K *
Jun 2 2005
```

Indication of firmware creation date.

Press again key  and the display shows the following:

```
* DC c107-12K *
10:37:34
```

Indication of firmware creation time.

Press again key  and the display shows the following:

```
* DC c107-12K *
B-Font: V5.01
```

Indication of font version of bitmap fonts.

Press again key  and the display shows the following:

```
* DC c107-12K *
V-Font: V1.01
```

Indication of font version of vector fonts.

Press again key  and the display shows the following:

```
* DC c107-12K *
FPGA V1.4.0 T9
```

Indication of FPGA version number.

Press again key  and the display shows the following:

```
* DC c107-12K *
16 MB Memory
```

Indication of storage capacity of device in MB.

Press again key  and the display shows the following:

```
* DC c107-12K *  
E MB FLASH
```

Indication of memory size of FLASHs in MB.

Press again key  and the display shows the following:

```
* DC c107-12K *  
A0 MO V.1.3.1 AB
```

Indication of version number for first processor (motor control).

Press again key  and the display shows the following:

```
* DC c107-12K *  
A1 MO V.1.3.1 AB
```

Indication of version number for second processor (motor control).

Press again key  and the display shows the following:

```
* DC c107-12K *  
A2 IO V.1.3.1 AB
```

Indication of version number for third processor (I/O control)

## 7.18 Display during printing

```
TESTETI:    wait
printed:    00000
```

The direct print module is in 'waiting' mode, i.e. ready to receive data.

Press key  to interrupt an active print order. The display shows the consumption of transfer ribbon:

```
Layoutnam ST 1111
C000000 100% RRR
```

Layoutnam: Name of the printed layout



ST: Status  
ST = Stopped  
RD = Ready

C: Counter  
Indication of already printed layouts

100%: Transfer ribbon in %

RRR: Reserved

Press key  key to continue the interrupted print order.

In case an active print order was interrupted by means of key  and afterwards key  pressed, then the print order was cancelled and the direct print module changes to the main menu.

```
* DC c107-12K *
14/09/05 10:16
```

```
Material Speed
200 mm/s
```

During the print order the number of layouts which already printed is indicated. Press the **F** key to change to the menu item 'material speed'.

```
Print Offset
(mm) 10.0
```

Press the  key to change to the menu item 'print offset'. The print offset can be changed during the running print order.

Press once more the **F** key and the direct print module changes again to the initial position, i.e. to the 'waiting' mode.



## 8 Compact Flash card

This print module series are equipped at the rear with a slot for Compact Flash card. By means of this memory card you can permanently save via interface graphics, text, layout data or information from database.



In case of a malfunction of your original memory card we recommend a copy of your most important data. Please use a commercial Compact Flash reader for PC.

### Insertion and removal of Compact Flash card

Insert Compact Flash card with contact side forwards to the slot that was planned for it.

In order to prevent wrong insertion of cards, both sides of Compact Flash cards have different guiding.

A small part of Compact Flash card is visible at the support at the direct print module rear, so you can remove the card easily with hand.



Please note that we support only Compact Flash cards of type 1 at the moment. The use of micro drives is not intended at this time.

### File and/or directory name

```
→<.>
A:\STANDARD\
```

```
→<Directory>
A:\STANDARD\
```

The direct print module handles your Compact Flash card as a DOS compatible file system.

After formatting Compact Flash card the STANDARD directory is automatically available. After switching on the direct print module or inserting Compact Flash card, this directory is the current one. Main and sub-directories are indicated in <> (e.g. <Directory>).



The maximum length of directory is 254 characters. It is not allowed to use the following characters neither in file nor in directory names:

```
: \ " * / < > ? |
```



Press key  to indicate the saved layouts onto the Compact Flash card.

Press key **F** to enter the Compact Flash card menu.

Press key  to arrive at the next menu item.

Press key **F** to return to the previous menu item.

Press key  to select a menu and to confirm a query.

Press key  and  to browse the contents of the current directory.

Press key  and  to change to the indicated directory.



Before first use of Compact Flash card in your direct print module we recommend to format the card in your direct print module.

**Selecting layout**Keys: 

```
→layout01      0
A:\STANDARD
```

Press key ◀ and ▶ to select the desired label in STANDARD directory.

Press key ● to select the layout.

```
Start print
No.layout: 12345
```

Select the number of layouts which you want to print.

Press key ● to start the print order.

After finishing the print order the display shows again the main menu.



It is NOT possible to change the directory. Enter the menu 'Change dir' to change the directory.

**Loading file from Compact Flash card**Keys: , **F**

```
CF Functions
Load file
```

Press key ● to select the 'Load file' menu item.

```
→<STANDARD>  0
A:\
```

Select the file you want to load and confirm the selection with key ●.

The loaded layout is now in the printer internal storage and after the loading procedure the display shows the main menu.

Press key  and enter the desired number you want to print. Confirm the selection with ● and the print order is started by an external signal (Input 1, PIN 1 and PIN 4).

**Saving layout onto Compact Flash card**Keys: , **F**, 

```
CF Functions
Save layout
```

Press key ● to select the 'Save layout' menu item.

Select the directory and/or layout you want to save and confirm the selection with key ●.

```
File exists
Overwrite?
```

Confirm the query with ● and the layout will be saved.



After the saving procedure the display shows again the main menu.



**Saving the configuration**

Keys: , **F**, , 

```
CF Functions
Save config
```







Press key  to select the 'Save configuration' menu item.  
 As standard, the proposed file name is config.cfg. This name can be changed by the user. In this file the parameters of print module are saved which are not saved permanent in the internal Flash.  
 Press key  to start the saving procedure.  
 After the saving procedure, the display shows again the main menu.

**Changing the directory**

Keys: , **F**, , , 

```
CF Functions
Change directory
```

```
←<.> M
A:\STANDARD\
```



Press key  to select the 'Change directory' menu item.  
 The lower line of display shows the directory which is selected at the moment.  
 Press key  and  to change the directory in the upper line.  
 Press key  and  to show all available directories.  
 Press key  to confirm the selected directory.  
 After changing the directory the display shows again the main menu.

**Deleting file from Compact Flash card**

Keys: , **F**, , , , 

```
CF Functions
Delete file
```

```
x<.> M
A:\STANDARD
```

Press key  to select the 'Delete file' menu item.  
 Select directory and/or layout you want to delete and confirm the selection with key .  
 The selected layout is deleted from the Compact Flash card.  
 After the deleting procedure the display shows again the first menu item 'Load file'.

**Formatting Compact Flash card**

The formatting procedure is recommended before using the Compact Flash card for the first time in the label printer.

Keys: , **F** , , , , , ,

CF Functions  
Format

Press key to select the 'Format' menu item.

Format A:

Press key to confirm the selection and the procedure is started.

When formatting the Compact Flash card the STANDARD directory is automatically created.

After the formatting procedure the display shows again the 'Load file' menu item.

**Indication of free memory space**

Keys: , **F** , , , , , ,

CF Functions  
Free memory

Press key to select the 'Free memory' menu item.

Free memory  
A: 253920 KB

The still available memory space onto Compact Flash card is indicated.

Press key to display again the 'Load file' menu item.

## 9 Maintenance and cleaning



### **DANGER!**

Risk of death by electric shock!

- ⇒ Disconnect the direct print module from power supply before performing any maintenance work.

### 9.1 Cleaning the printhead



When cleaning the label printer, personal protective equipment such as safety goggles and gloves are recommended.

Printing can cause accumulation of dirt at printhead e.g. by colour particles of transfer ribbon, and therefore it is necessary to clean the printhead in regular periods depending on operating hours, environmental effects such as dust etc.



### **CAUTION!**

Printhead can be damaged!

- ⇒ Do not use sharp or hard objects to clean the printhead.
- ⇒ Do not touch protective glass layer of the printhead.

- Remove ribbon cassette.
- Clean printhead surface with special cleaning pen or a cotton swab dipped in pure alcohol.
- Allow printhead to dry for 2-3 minutes before commissioning the device.



The handling instructions for the use of Isopropanol (IPA) must be observed. In the case of skin or eye contact, immediately wash off the fluid thoroughly with running water. If the irritation persists, consult a doctor. Ensure good ventilation.

### 9.2 Replacing the printhead



### **CAUTION!**

The printhead can be damaged by static electricity discharges and impacts!

- ⇒ Set up direct print module on a grounded, conductive surface.
- ⇒ Ground your body, e.g. by wearing a grounded wristband.
- ⇒ Do not touch contacts on the plug connections (2, 3).
- ⇒ Do not touch printing line (5) with hard objects or your hands.

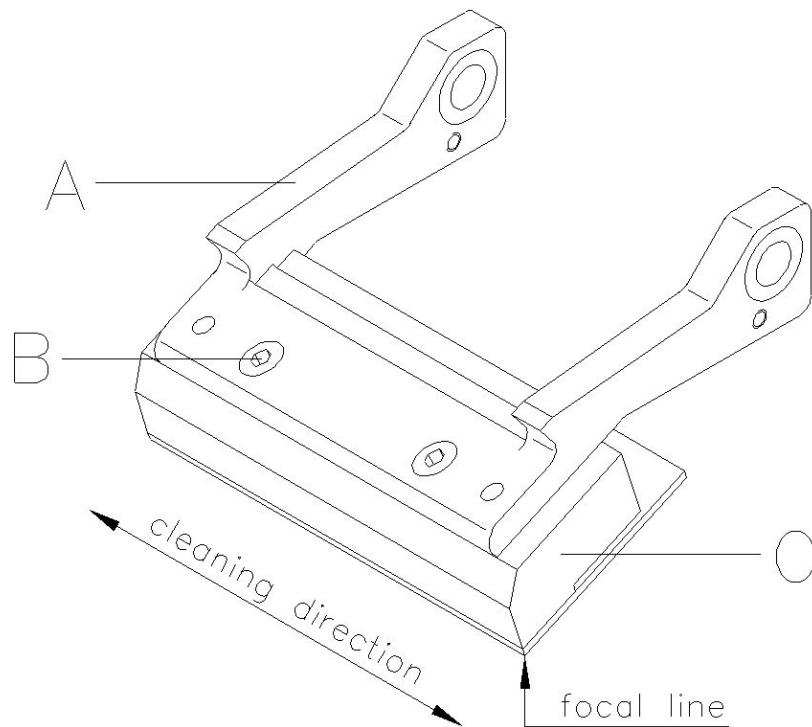

**Figure 24**

### Removing the printhead

- Remove ribbon cassette.
- Move printhead unit in an appropriate service position.
- Press printhead support (A) slightly downwards until an Allen key (2.5) can be inserted in the screws (B).
- Remove screws (B) and afterwards the printhead (C).
- Remove rear-mounted connection assembly from printhead

### Installing the printhead

- Insert connection assembly to the new printhead.
- Position printhead in printhead support (A), so the engaging pieces catch in the appropriate holes in the printhead support (A).
- Hold printhead holder (A) with a finger slightly on the pressure roll and check the correct position of printhead (C).
- Screw in screw (B) and tighten it with an Allen key.
- Insert again ribbon cassette (see chapter 5 on page 37).
- Enter the resistance value of the new printhead in the 'Service Functions/Heater resistance'. The value is indicated on the type plate of printhead.
- Start a test print to check printhead position.

### 9.3 Angle adjustment\*

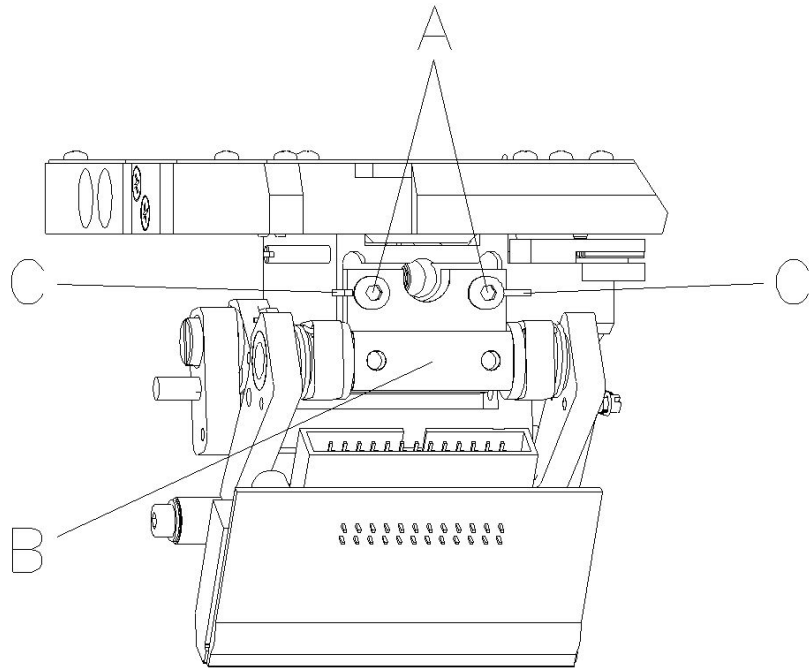

The installation angle of the printhead is default 26° to the print surface. However, manufacturing tolerances of printhead and mechanics can require another angle.



#### CAUTION!

Damage of printhead by unequal use!  
Higher wastage of ribbon by faster ripping.

⇒ Change factory settings only in exceptional cases.

- Loosen slightly two Allen head screws (A).
- Move adjusting part (B) to adjust the angle between printhead and printhead support.  
move downwards = decrease angle  
move upwards = increase angle
- Tighten again the Allen head screws (A).
- Start a print order with approx. 3 layouts to check the correct unwrinkled ribbon run.



The slots (C) serve for position control. Pay attention to a parallel adjustment.

---

\* intermittent mode

## 9.4 Print quality optimisation

The following table shows some possibilities to improve the print quality.

Generally you have to note: the higher the print speed the lower the print quality.

Problem	Possible solution
Regular inferior print quality	<ul style="list-style-type: none"> <li>• Increase contrast</li> <li>• Increase pressure</li> <li>• Control 'alternative' transfer ribbon guiding</li> <li>• Reduce print speed</li> <li>• Reduce transfer ribbon speed</li> <li>• Reduce distance between printhead and print surface</li> <li>• Change combination of transfer ribbon and print medium</li> <li>• Control print surface (too soft)</li> <li>• Change print angle</li> </ul>
Partial inferior print quality (on one side)	<ul style="list-style-type: none"> <li>• Align surface parallel to printhead</li> <li>• Set regular transfer ribbon tension</li> <li>• Set regular printhead angle</li> </ul>
Partial inferior print quality (periodical)	<ul style="list-style-type: none"> <li>• Sharp surface even</li> <li>• Reinforce surface against bending</li> </ul>

## 9.5 Cycle optimisation\*

Taktzahl = abgeschlossener Druckzyklus pro Zeiteinheit.

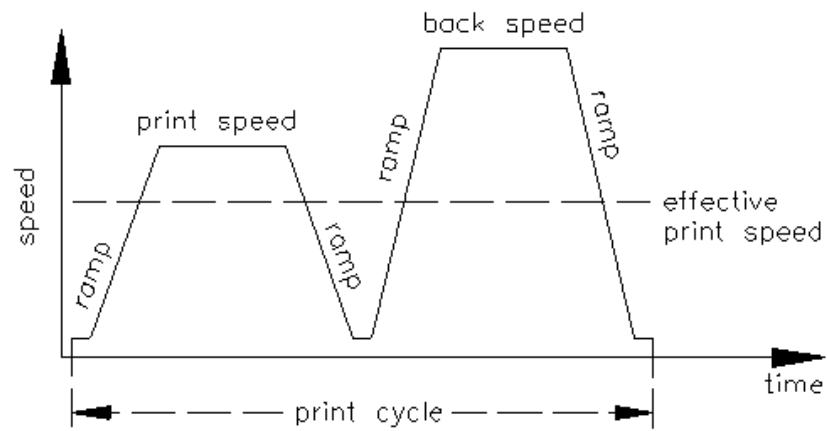

In case of 'time critical' applications you have the possibility with a good selection of different device parameters to increase the effective print speed and in this way the clock cycle.

- Generally increase the print speed.
- Generally increase the back speed.
- Increase acceleration and brake ramp.
- Change zero point of machine.
- Avoid vertical installation position of print mechanics. Install the machine in horizontal position.
- Control the short distance between printhead and print surface.
- Switch off foil saving automatic.
- Optimise the layout to a short print way, i.e. less blanks, no borders at the top res. bottom, rotate the layout.

---

\* intermittent mode





## 10 Signal diagrams

### 10.1 Continuous mode



The line 'data receipt' indicates when the direct print module receives data.

**Dispensing mode:**  
**Dynamic**

Number of layouts per print order: 1  
Data memory: standard  
Ribbon save: On  
Trigger input print start: increasing slope

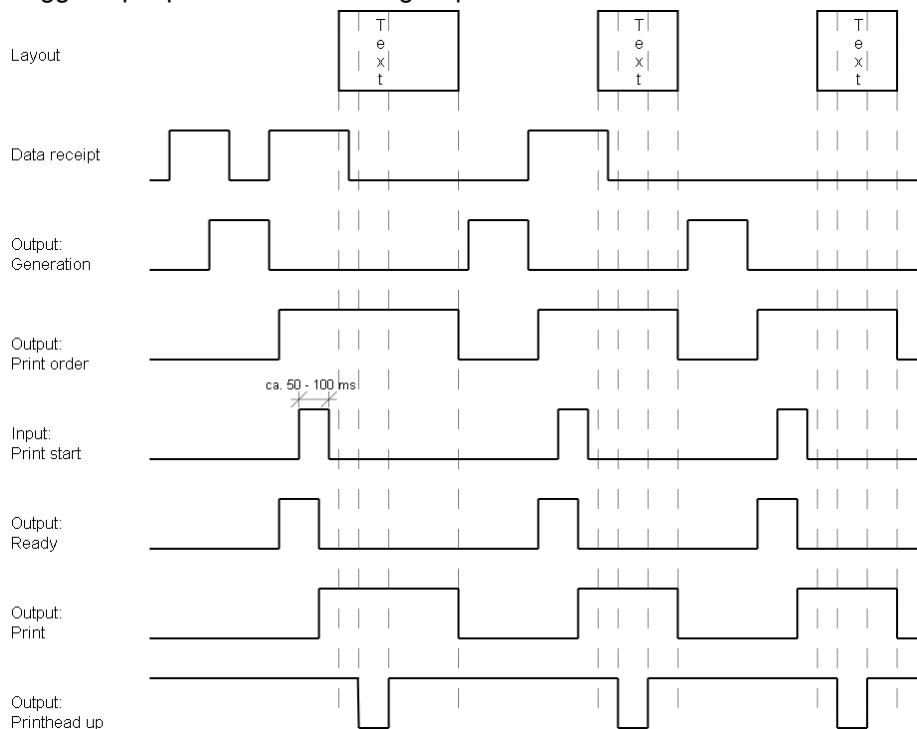

**Layout:**

In 'dispensing mode: dynamic' the layout distance onto the material is not determined by the layout length but by the time between start impulse and print start input.

Because of the fact that the setting 'data memory: standard' the next print order is generated after the previous one is finished and a print order is only finished after the feed of the complete layout, the smallest possible time between two start impulses depends also from the layout length.

In case the printable data is only at the beginning of the layout and the rest of the layout is empty, then it is possible to decrease the time of start impulse by minimising the layout length (not for 'data memory: extended').

**Data receipt:**

As soon as the generation of a layout is finished, a new one is send to the direct print module. The time of receipt for the first layout is normally shorter because at this time the direct print module has no further action. At receipt of the following layout, the time of receipt is longer because the direct print module receives data and prints at the same time.

Number of layouts per print order: 1  
 Data memory: extended  
 Ribbon save: On  
 Trigger input print start: increasing slope

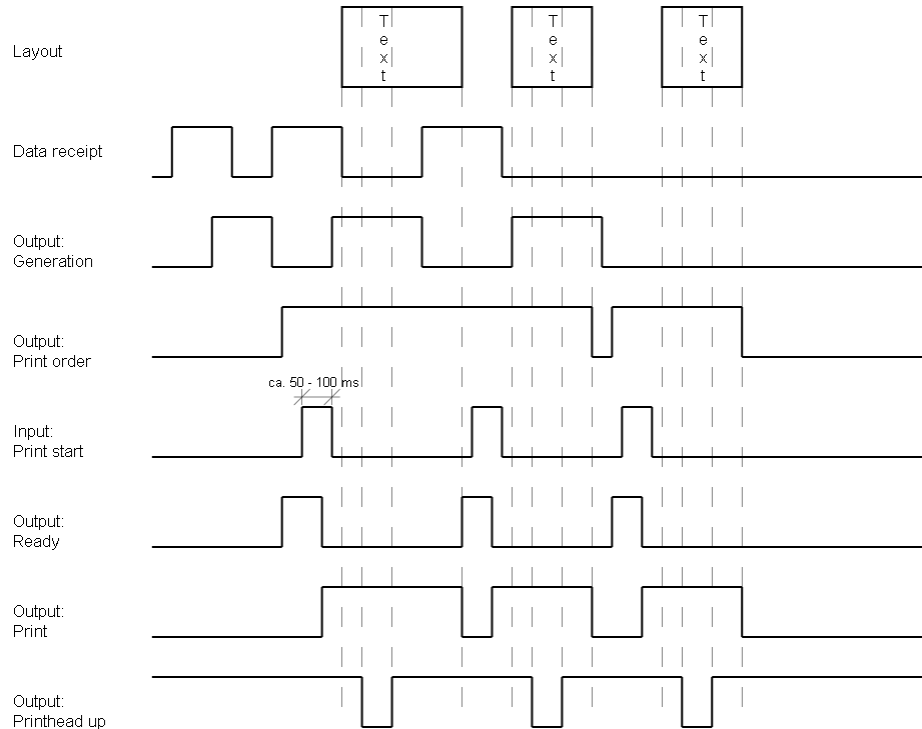

#### Layout:

For a better comparison we used the same layouts as before.

#### Data receipt:

As soon as the generation of the layout is finished a new one is send to the direct print module.

#### Data receipt/generation:

The time of receipt for the first layout is normally shorter because at this time the direct print module has no further action. At receipt of the following layout, the time of receipt is longer because the direct print module receives data and prints at the same time.

#### Generation:

In mode 'data memory: extended' already received data is always generated after the start of a print order.

#### Print order:

Before the current print order is finished the next one is already generated. The signal output is therefore active and the next start impulse can be send.

#### Print:

Before the next start impulse is send, the print has to be finished as otherwise the impulse is ignored.

Number of layouts per print order: 3  
 Data memory: Off/standard/extended  
 Ribbon save: On  
 Trigger input print start: increasing slope

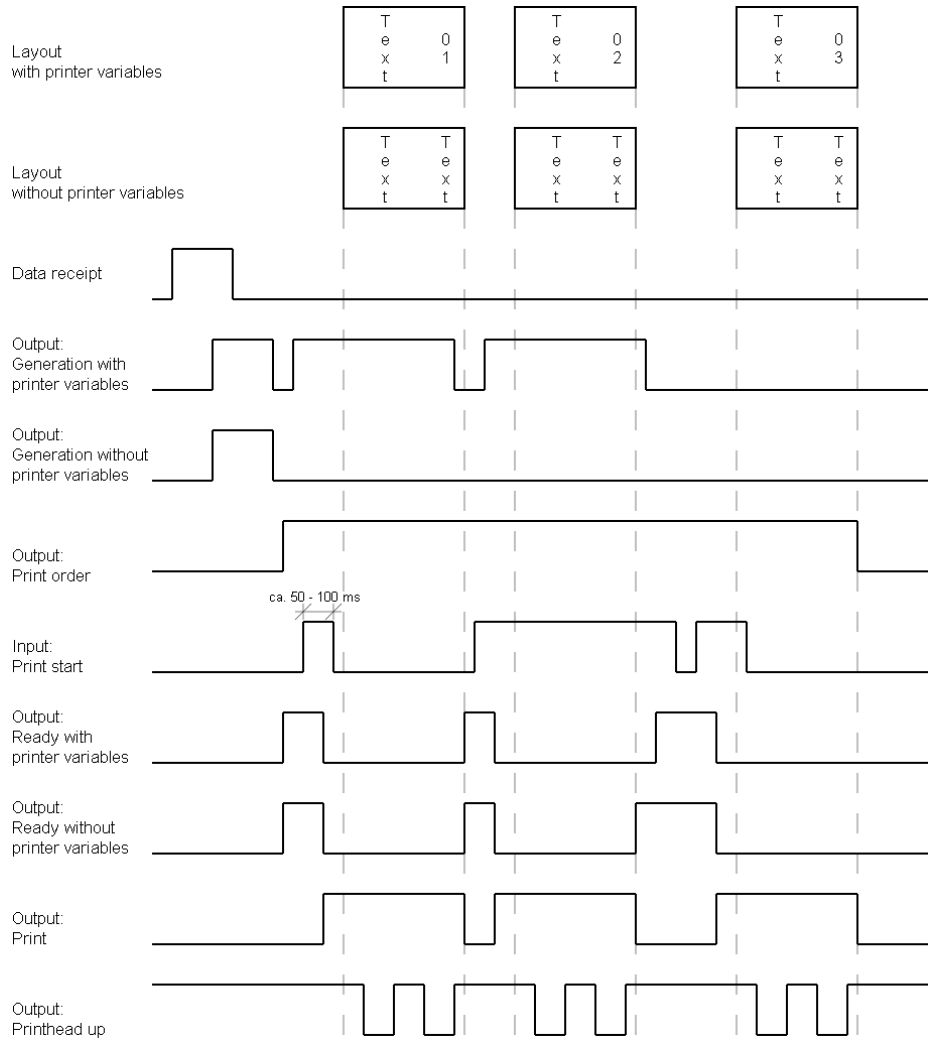

**Layout/generation with printer variables:**

The use of printer variables means that each layout is different and the direct print module has to generate several parts of the layout anew, e.g. variable counter.

**Layout/generation without printer variables:**

Each of the 3 layouts which are to print are the same and therefore it is only necessary to generate the layout once.

**Data receipt:**

Because only 1 print order is send, the direct print module has only to receive once.

**Print order:**

As the print order consists of 3 layouts, the print order output is active as long as all 3 layouts are printed.

**Print start/print:**

In dispensing mode dynamic only the slope of the start impulse is recognised as valid print start signal. However, the impulse should have a minimum impulse width of 50 ms.

**Dispensing Mode:  
Static**

Number of layouts per print order: 4  
 Data memory: Off/standard/extended  
 Ribbon save: On  
 Trigger input print start: level High

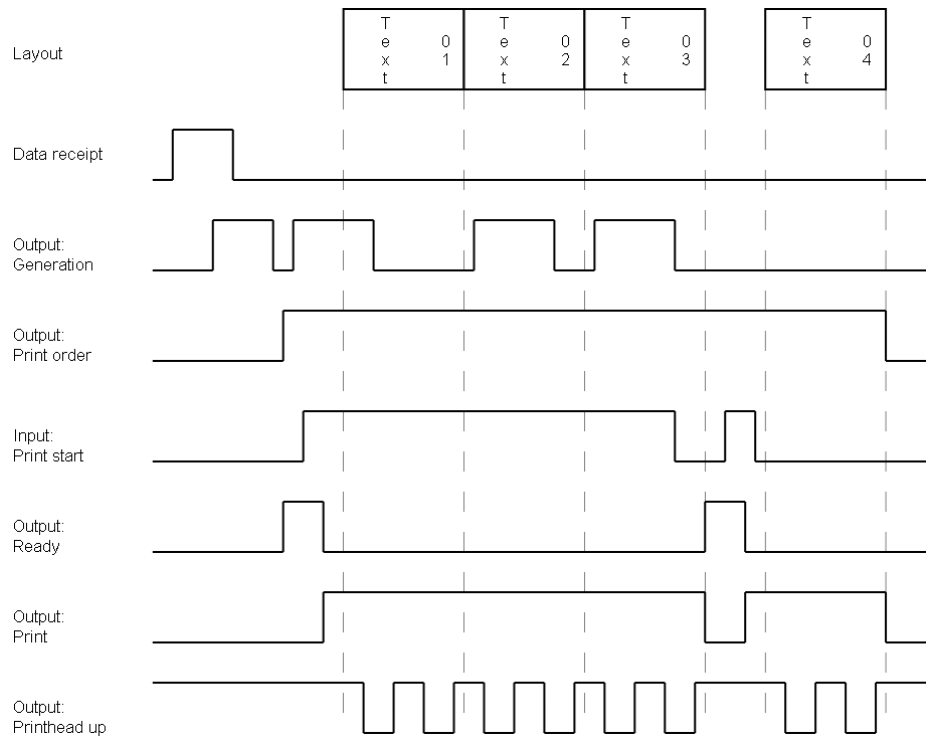

**Layout:**  
 4 layouts with counter

**Print start/print:**

In 'dispensing mode: static' the level of the start impulse is recognised as valid start signal. In case the level is activated then the print is continued immediately if the following layout is already generated. After deleting the signal, the machine prints until the end of the current layout and then the direct print module waits for the next start impulse.

### 10.2 Intermittent mode

#### Mode 1 (single item processing)

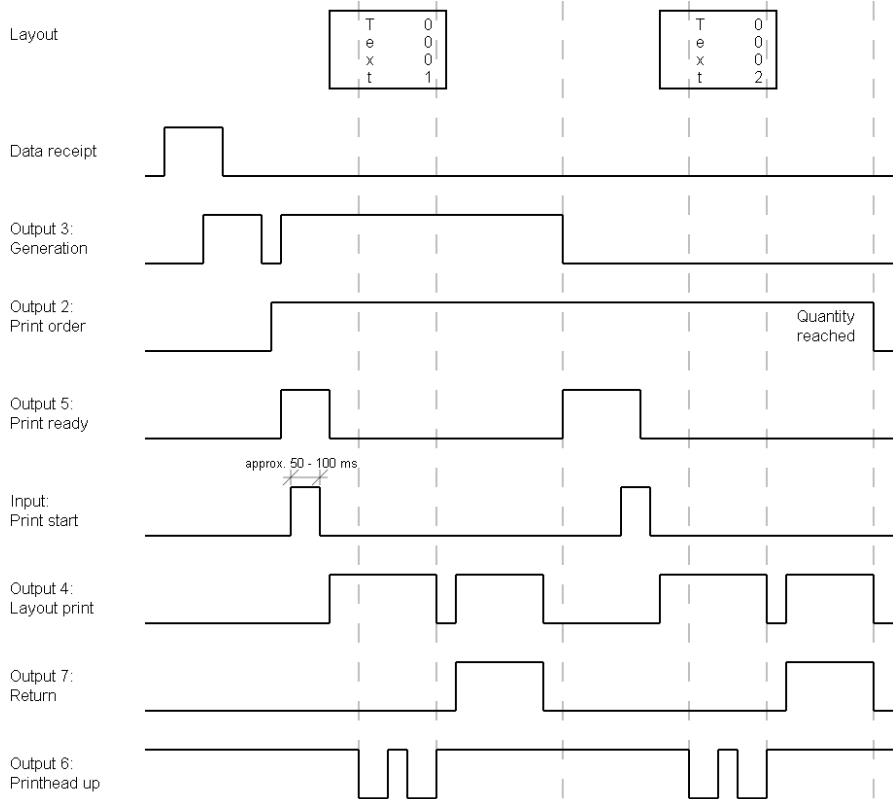

#### Mode 2 (continuous mode)

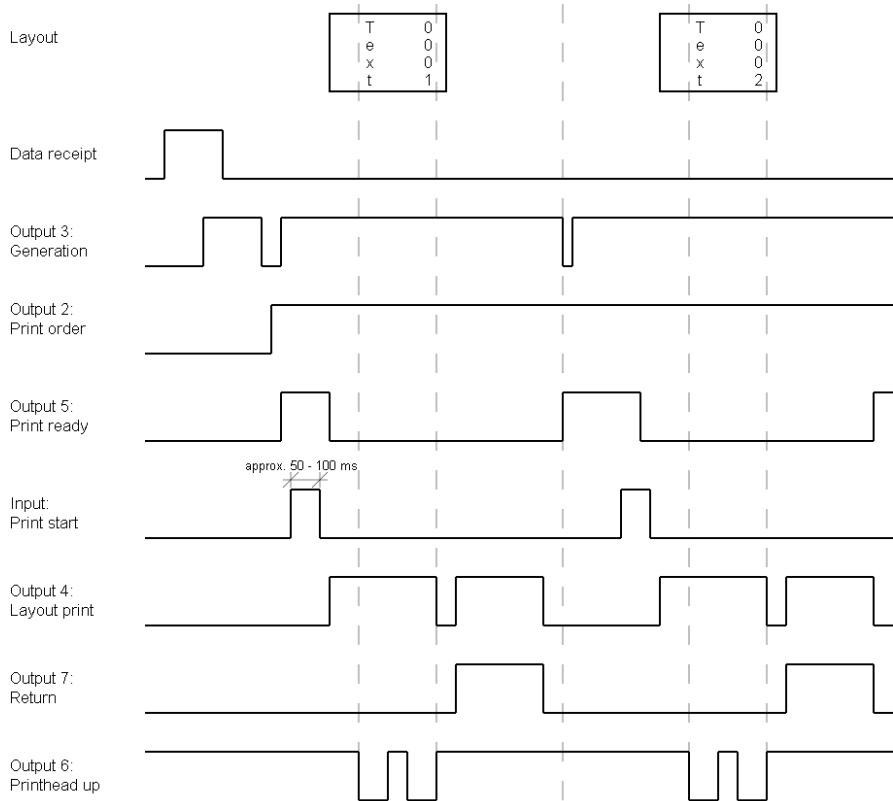

**Mode 4  
(continuous mode,  
return without 'layout  
printing' signal)**

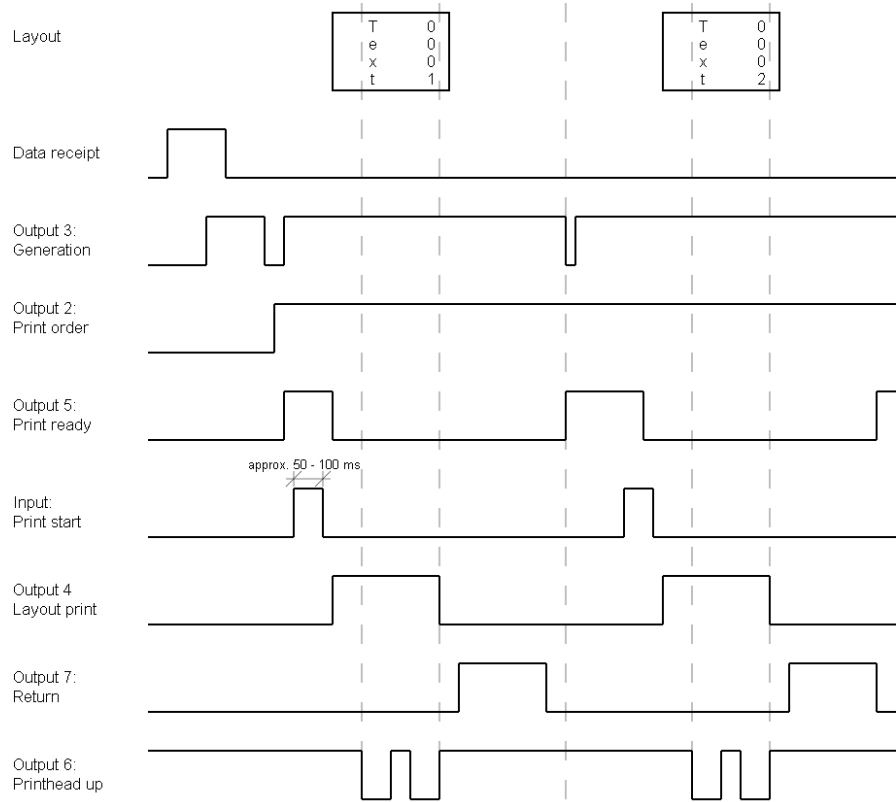

## 11 Error correction

Error message	Cause	Remedy
1 Line too high	Line rises up completely or partly over the upper edge of label.	Move line down (increase Y value). Check rotation and font.
2 Line too low	Line rises up completely or partly over the bottom edge of label.	Move line up (reduce X value). Check rotation and font.
3 Character set	One res. several characters of the text is res. are not available in the selected font.	Change text. Change font.
4 Unknown code type	Selected code is not available.	Check code type.
5 Invalid position	Selected position is not available.	Check position.
6 CV font	Selected font is not available.	Check font.
7 Vector font	Selected font is not available.	Check font.
8 Measuring label	While measuring no label was found. Set label length is too large.	Check label length and if labels are inserted correctly. Restart measuring anew.
9 No label found	No label available. Soiled label photocell. Labels not inserted correctly.	Insert new label roll. Check if labels are inserted correctly. Clean the label photocell.
10 No ribbon	During the print order the ribbon roll becomes empty. Defect at the transfer ribbon photocell.	Change transfer ribbon. Check transfer ribbon photocell (service functions).
11 COM FRAMING	Stop bit error.	Check stop bits. Check baud rate. Check cable (printer and PC).
12 COM PARITY	Parity error.	Check parity. Check baud rate. Check cable (printer and PC).
13 COM OVERRUN	Loss of data at serial interface (RS-232).	Check baud rate. Check cable (printer and PC).

Error message	Cause	Remedy
14 Field numer	Received line number is invalid at RS-232 and Centronics.	Check sent data. Check connection PC - printer.
15 Length mask	Invalid length of received mask statement.	Check sent data. Check connection PC - printer.
16 Unknown mask	Transferred mask statement is invalid.	Check sent data. Check connection PC - printer.
17 Missing ETB	No end of data found.	Check sent data. Check connection PC - printer.
18 Invalid character	One res. several characters of the text is res. are not available in the selected font.	Change text. Change font.
19 Invalid statement	Unknown transferred data record.	Check sent data. Check connection PC - printer.
20 Invalid check digit	For check digit control the entered res. received check digit is wrong.	Calculate check digit anew. Check code data.
21 Invalid SC number	Selected SC factor is invalid for EAN res. UPC.	Check SC factor.
22 Invalid number of digits	Entered digits for EAN res. UPC are invalid < 12; > 13.	Check number of digits.
23 Check digit calculation	Selected check digit calculation is not available in the bar code.	Check calculation of check digit. Check bar code type.
24 Invalid extension	Selected zoom factor is not available.	Check zoom factor.
25 Offset sign	Entered sign is not available.	Check offset value.
26 Offset value	Entered offset value is invalid.	Check offset value.
27 Printhead temperature	Printhead temperature is too high. Defective printhead sensing device.	Reduce contrast. Change printhead.
28 Cutter error	With cut an error occurred. Paper jam.	Check label run. Check cutter run.
29 Invalid parameter	Entered data do not correspond to the characters allowed from the application identifier.	Check code data.



<b>Error message</b>	<b>Cause</b>	<b>Remedy</b>
30 Application Identifier	Selected application identifier is not available in GS1-128.	Check code data.
31 HIBC definition	F Missing HIBC system sign. Missing primary code.	Check definition of HIBC code.
32 System clock	Real Time Clock function is selected but the battery is empty. Defective RTC.	Change battery. Change RTC component.
33 No CF interface	Interrupted connection CPU - CF card. Defective CF card interface.	Check connection CPU - CF card interface. Check CF card interface.
34 No print memory	No print CF found.	Check CF assembly on CPU.
35 Cover open	At start of a print order the printhead is open.	Close the printhead and start print order anew.
36 BCD invalid format	BCD error Invalid format for the calculation of Euro variable.	Check entered format.
37 BCD overflow	BCD error Invalid format for the calculation of Euro variable.	Check entered format.
38 BCD division	BCD error Invalid format for the calculation of Euro variable.	Check entered format.
39 FLASH ERROR	Flash component error.	Run a software update. Change CPU.
40 Length command	Invalid length of the received command statement.	Check data sent. Check connection PC - printer.
41 No drive	CF card not found / not correctly inserted.	Insert CF card correctly.
42 Drive error	Impossible to read CF card (faulty).	Check CF card, if necessary change it.
43 Not formatted	CF Card not formatted.	Format CF card.
44 Delete current directory	Attempt to delete the actual directory.	Change directory.
45 Path too long	Too long indication of path.	Indicate a shorter path.

<b>Error message</b>	<b>Cause</b>	<b>Remedy</b>
46 Drive write-protected	Memory card is write-protected.	Deactivate write protection.
47 Directory not file	Attempt to indicate a directory as file name.	Correct your entry.
48 File already open	Attempt to change a file during an access is active.	Select another file.
49 No file/directory	File does not exist on CF card.	Check file name.
50 Invalid file name	File name contains invalid characters.	Correct entry of name, remove special characters.
51 Internal file error	Internal file system error.	Please contact your distributor.
52 Root full	The max. number (64) of main directory entries is reached.	Delete at least one main directory entry and create subdirectories.
53 Drive full	Maximum CF capacity is reached.	Use new CF Card, delete no longer required files.
54 File/directory exists	The selected file/directory already exists.	Check name, select a different name.
55 File too large	During copying procedure not enough memory space onto target drive available.	Use a larger target card.
56 No update file	Errors in update file of firmware.	Start update file anew.
57 Invalid graphic file	The selected file does not contain graphic data.	Check file name.
58 Directory not empty	Attempt to delete a not empty directory.	Delete all files and sub-directories in the desired directory.
59 No interface	No CF card drive found.	Check connection of CF card drive. Contact your distributor
60 No CF card	No CF card is inserted.	Insert CF card in the slot.
61 Webserver error	Error at start of web server.	Please contact your distributor.
62 Wrong FPGA	The direct print module is equipped with the wrong FPGA.	Please contact your distributor.
63 End position	The label length is too long. The number of labels per cycle is too much.	Check label length res. the number of labels per cycle.

<b>Error message</b>	<b>Cause</b>	<b>Remedy</b>
64 Zero point	Defective photocell.	Change photocell.
65 Compressed air	Pressure air is not connected.	Check pressure air.
66 External releaser	External print release signal is missing.	Check input signal.
67 Row too long	Wrong definition of column width res. number of columns.	Reduce the column width res. correct the number of columns.
68 Scanner	The connected bar code scanner signals a device error.	Check the connection scanner/printer. Check scanner (dirty).
69 Scanner NoRead	Bad print quality. Printhead completely soiled or defective. Print speed too high.	Increase contrast. Clean printhead or exchange (if necessary). Reduce print speed.
70 Scanner data	Scanned data does not correspond to the data which is to print.	Exchange printhead.
71 Invalid page	As page number either 0 or a number > 9 is selected.	Select a number between 1 and 9.
72 Page selection	A page which is not available is selected.	Check the defined pages.
73 Page not defined	The page is not defined.	Check the print definition.
74 Format user guiding	Wrong format for customised entry.	Check the format string.
75 Format date/time	Wrong format for date/time.	Check the format string.
76 Hotstart CF	No CF card found.	If option hotstart was activated, a CF card must be inserted. Switch off the printer before inserting the memory card.
77 Flip/Rotate	Selection of print of several columns and also mirror/rotate.	It is only possible to select one of both functions.
78 System file	Loading of temporary hotstart files.	Not possible.
79 Shift variable	Faulty definition of shift times (overlapping times).	Check definition of shift times.
80 GS1 Databar	General GS1 Databar error.	Check definition and parameter of GS1 Databar code.
81 IGP error	Protocol error IGP.	Check sent data.

<b>Error message</b>	<b>Cause</b>	<b>Remedy</b>
82 Time generation	Printing creation was still active at print start.	Reduce print speed. Use printers' output signal for synchronisation. Use bitmap fonts to reduce generating time.
83 Transport protection	Both DPM position sensors (start/end) are active.	Displace zero point sensor Check sensors in service functions menu
84 No font data	Font and web data is missing.	Run a software update.
85 No layout ID	Label ID definition is missing.	Define label ID onto the label.
86 Layout ID	Scanned data does not correspond to defined ID.	Wrong label loaded from CF card.
87 RFID no label	RFID unit cannot recognise a label.	Displace RFID unit or use an offset.
88 RFID verify	Error while checking programmed data.	Faulty RFID label. Check RFID definitions
89 RFID timeout	Error at programming the RFID label.	Label positioning. Faulty label.
90 RFID data	Faulty or incomplete definition of RFID data.	Check RFID data definitions.
91 RFID tag type	Definition of label data does not correspond with the used label.	Check storage partitioning of used label type
92 RFID lock	Error at programming the RFID label (locked fields).	Check RFID data definitions. Label was already programmed.
93 RFID programming	Error at programming the RFID label.	Check RFID definitions.
94 Scanner timeout	The scanner could not read the bar code within the set timeout time.	
	Defective printhead. Wrinkles in transfer ribbon. Scanner wrong positioned. Timeout time too short.	Check printhead. Check transfer ribbon. Position scanner correctly, corresponding to the set feeding. Select longer timeout time.

<b>Error message</b>	<b>Cause</b>	<b>Remedy</b>
95 Scanner layout difference	Scanner data does not correspond to bar code data.	Check adjustment of scanner. Check scanner settings / connection.
96 COM break	Serial interface error.	Check settings for serial data transmission as well as cable (printer-PC).
97 COM general	Serial interface error.	Check settings for serial data transmission as well as cable (printer-PC).
98 No software printhead FPGA	No printhead-FPGA data available.	Please contact your responsible distributor.
99 Load software printhead FPGA	Error when programming printhead-FPGA.	Please contact your responsible distributor.
100 Upper position	Sensor signal up is missing (option APL 100).	Check input signals / compressed-air supply.
101 Lower position	Sensor signal down is missing (option APL 100).	Check input signals / compressed-air supply.
102 Vacuum plate empty	Sensor does not recognise a label at vacuum plate (option APL 100).	Check input signals / compressed-air supply.
103 Start signal	Print order is active but device not ready to process it.	Check start signal.
104 No print data	Print data outside the defined label. Selection of wrong module type (design software).	Check selected module type. Check selection of left/right version.
105 Printhead	No original printhead is used.	Check the used printhead. Contact your distributor.
106 Invalid Tag type	Wrong Tag type. Tag data do not match the Tag type in the printer.	Adapt data or use the correct Tag type.
107 RFID invalid	RFID module is not activated. No RFID data can be processed.	Activate RFID module or remove RFID data from label data.
108 GS1-128 invalid	Transferred GS1-128 bar code is invalid.	Verify bar code data (see GS1-128 bar code specification).
109 EPC parameter	Error at EPC calculation.	Verify data (see EPC specification).

<b>Error message</b>	<b>Cause</b>	<b>Remedy</b>
110 Housing open	When starting the print order the housing cover is not closed.	Close the housing cover and start the print order anew.
111 EAN.UCC code	Transferred EAN.UCC code is invalid.	Verify bar code data (see corresponding specification).
112 Print carriage	Printing carriage does not move.	Check gear belt (possibly broken).
113 Applicator error	Error while using applicator.	Check applicator.
114 Left position	Left final position switch is not in correct position.	Check LEFT final position switch for correct function and position. Check function of pneumatics for cross traverse.
115 Right position	Right final position switch is not in correct position.	Check RIGHT final position switch for correct function and position. Check function of pneumatics for cross traverse.
116 Print position	The print position is not correct.	Check TOP and RIGHT final position switch for correct function and position. Check pneumatics for function
117 XML parameter	The parameters in the XML file are not correct.	Please contact your responsible distributor.
118 Invalid variable	Transferred variable is invalid with customized entry.	Select correct variable without customized entry and transfer it.
119 No ribbon	During the print order the ribbon roll becomes empty. Defect at the transfer ribbon photocell.	Change transfer ribbon. Check transfer ribbon photocell (service functions).
120 Wrong directory	Invalid target directory when copying.	Target directory must not be within the source directory. Check target directory.
121 No label found	No label found at the rear printhead (DuoPrint). Soiled label photocell. Labels not inserted correctly.	Insert new label roll. Clean the label photocell. Check if labels are inserted correctly.
122 IP occupied	The IP address was already assigned.	Assign a new IP address.

<b>Error message</b>	<b>Cause</b>	<b>Remedy</b>
123 Print asynchronous	<p>The label photocell do not work in the order as it is expected according to print data.</p> <p>The settings of the photocell are not correct.</p> <p>Settings of label size and gap size are not correct.</p> <p>No label found at the rear printhead.</p> <p>Soiled label photocell.</p> <p>Labels not inserted correctly.</p>	<p>Check label size and gap size.</p> <p>Check label photocell settings.</p> <p>Check correct loading of label material.</p> <p>Insert new label roll.</p> <p>Clean the label photocell.</p> <p>Check if labels are inserted correctly.</p>
124 Speed too slow	Print speed is too slow.	Increase the speed of customers' machine.





## 12 Additional information

### 12.1 Column printing

With this direct print module several columns can be printed, i.e. the information of one column can be printed several times (depending on its width) on a layout. Caused by this the use of the complete print width is possible and the generating time is enormously reduced.

For example 4 columns with a width of 25 mm or 2 columns with a width of 50 mm can be printed onto a layout with a width of 100 mm. Please note that the first layout is always the one with the largest x coordinate, i.e. it has the largest distance to the printhead.

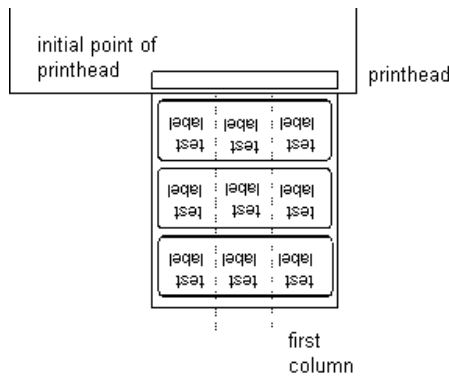

#### Setting column printing

Press key **F** to change to the function menu.

Press key **▶** as long as to the 'Layout' menu.

Press key **●** to confirm the selection.

Press key **▶** as long as the menu item (see illustration) appears.

```
Width:      20.0
Columns:    4
```

Press key **▲** and **▼** to set the layout width. As column width the width of one layout is entered, e.g. 20.0 mm.

Press key **◀** and **▶** to enter the number of columns.

Press key **▲** and **▼** to change the number of columns, e.g. 4 columns at a layout width of 20.0 mm.

Press key **□** to start a print with indication of number of layouts and number of lines. The number of layouts corresponds to the number of layouts that are to print.

e.g. columns: 3, items: 4

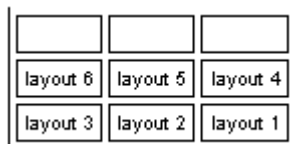

The first four layouts were printed but not layout 5 and 6.

## 12.2 Password

**Example 1** The supervisor programs a Compact Flash card directly with the direct print module. He stores 10 different layouts. As well he adjusts the printer parameters, like contrast, speed, etc. to the corresponding values. The user is only supposed to read the layouts from memory card and to print them. Therefore the supervisor blocks the function menu and the entry function by a password.

**Example 2** The printer is connected to a PC. The user is only supposed to take the layouts dispensed by the printer and stick them on. To prevent, that the layouts or the printer set-up will not be changed, the supervisor blocks all printer functions (e.g. function menu, entry menu, etc.) by a password.

**Example 3** The user has to change several texts before printing. It is not allowed to change any masks (fonts, position, etc.). Therefore the supervisor blocks the entry of mask and the function menu. By this means the user indeed can print layouts, but the printer set-up and the masks of the layouts can't be changed.

To receive a most flexible password protection, the printer functions will be divided into several function groups:

- 1. Function menu** In the function menu the printer parameters can be changed (contrast, speed, mode, ...). The password protection prevents modifications at the printer settings.
- 2. Compact Flash card** With the functions of your Compact Flash card layouts can be stored, loaded, ....  
Here the password protection has to separate, if none or only reading functions are allowed.
- 3. Print functions** With key quant a print can be produced. In case the printer is connected to a PC, it can be useful, that the user is not able to produce a print manually. So the password protection prevents that prints can be produced manually.

Because of these different function groups the password protection is very flexible. The printer can be adjusted best to its actual order, as only certain functions are blocked.

**Password definition**

In case no password is defined res. the password protection is not activated, all functions can be used. In the function menu you will find the menu item 'Password', where the password can be entered and the password protection activated.

Press key  as long as to the 'Password' menu.

Press key  to confirm the selection.

```

Password 0000 J
F:0 MC:0 D:0
    
```



Meaning of abbreviations:

- F      Function menu
- CF     Compact Flash card functions
- D      Print functions

In case the password protection is active, but the function menu is not protected, the password



(4-digit number between 0000 and 9999) has to be entered first, so the above shown display appears. Now changes can be done. In the first line the user can define the password (4-digit number).

Press key  to continue.

Press key  and  to activate/deactivate the password protection (yes/no).

Press key  to change to the second line.

Press key  and  to block/release individual function groups.

Press key  and  to change from one group to the next one.

- F:      Function menu            0...open  
   1...locked
- CF:     Compact Flash card    0...open  
   1...only reading access  
   2...access blocked
- D:      Printer guiding            0...open  
   1...open  
   2...no manual print release

**Activate blocked function**

In case the user wants to perform a blocked function, he has to enter the valid password first.

```

Password Prot.
0000
    
```

The entered password has to be confirmed with E. In case the correct password has been entered the desired function can be performed. If the entered password was invalid no error message appears but the main menu will be displayed.

## 12.3 Hotstart



Because of the fact that no battery-buffered SRAM is available, the necessary data has to be saved in another way, i.e. the data is saved onto Compact Flash card. Therefore the option Compact Flash card is a condition for the hotstart menu item.

The function hotstart contains e.g. that in case of a power failure the currently loaded layout can be further processed without any loss of data.

Moreover a print order can be interrupted and to be continued after switching on the printer anew.



At an active hotstart all necessary data is stored on the Compact Flash therefore do not remove the card during operation. When removing during operation, this causes the loss of all data on the Compact Flash Card.

### **Saving the current layout**

In case the hotstart function is set to on, at the start of a print order the data of the current layout is saved to the corresponding directory of the Compact Flash card.

However the following conditions have to be fulfilled:

- Compact Flash card inserted in drive A
- Compact Flash card not write protected
- Enough free storage space onto Compact Flash card

An error message appears in case these conditions are not fulfilled.

### **Saving the printer order state**

At switching off the printer the state of the current print order is saved to the corresponding directory of the Compact Flash Card.

However the following conditions have to be fulfilled:

- Compact Flash card inserted in drive A
- Compact Flash card not write protected
- Enough free storage space onto Compact Flash card

### **Loading a layout and printer order state**

In case the hotstart function is set to On, at a new start of printer the saved layout data and the print order state is loaded from the corresponding file on the Compact Flash card. Because of this reason a Compact Flash card has to be inserted at switching on the printer. In case it is impossible to load the data an error message appears.

**Starting the print order**

In case at switching off the direct print module a print order was active, then a print start is released automatically and the required res. actual number of printed layouts is refreshed.

In case the print order was stopped at switching off the direct print module, it is again set to the stopped mode after switching on the direct print module anew.

In case a customized entry was active during switching off the direct print module, the window for the first customized variable is displayed.

**Refreshing the variable counter**

As in the intended file only the start values of the counter are saved, they are refreshed at a new start of the print order by means of the number of printed layouts. Each counter is counted corresponding from its start value. Afterwards the position of the current and the next counter update are correctly set by means of the update intervals.



Make sure that in case graphics are onto the layout they have to be saved onto Compact Flash card.



## 13 Ribbon save

### 13.1 Explication

Optimierung = maximum utilisation of transfer ribbon

#### Layout



#### Transfer ribbon without ribbon save

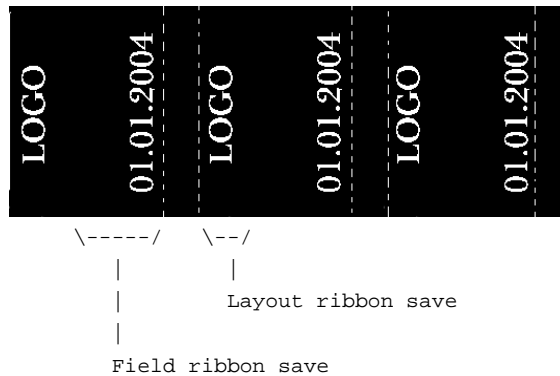

#### Transfer ribbon with ribbon save

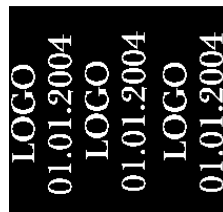

#### Procedure

In principle the ribbon save is achieved by the way that the transfer ribbon in phases in those no printing is effected stopped or decelerated. If sufficient time is available, the transfer ribbon which was not used for printing can be retracted to print on it afterwards. The possibility of ribbon save and in this way of the print quality are to be connected with the available time which is needed for decelerating and accelerating of transfer ribbon. There are two different types of ribbon save:

#### Field ribbon save

It is tried to save transfer ribbon with gaps within the layout. Because of the fact that the gaps are usually very small, only little time is available. Therefore a feedback is not reasonable (lack of time).

#### Layout ribbon save

The gaps between the layouts are optimised. Usually more time is available here. The loss of transfer ribbon between the layouts which result from accelerating and decelerating of transfer ribbon can be corrected by means of the return.

### 13.2 Standard ribbon save (continuous mode)

Press key **F** to access the function menu.

Press key **▲** as long as you arrive at the 'Ribbon save' menu.

Press key **●** to select the menu.

Function Menu  
Ribbon Save

Mode            Speed  
Standard       600

Press key **▼** and **▲** to select the ribbon save mode 'Standard'.

Press key **▲** to access the following menu item.

R-Correction  
-1 mm

#### R-Correction

**0 mm** = It is always so far retracted that an optimal ribbon save is reached (no loss of transfer ribbon). This is rather rarely realised, as the ribbon position can deviate because of inaccuracies at speed measurement (encoder).

Default: -1 mm

**-xx mm** = The feedback can be made smaller. It causes loss of transfer ribbon but the number of cycles is increased. If the value is increased to the complete backfeed length then the direct print module sets automatically the max. value and no more backfeed is accomplished.

**+xx mm** = The feedback can be made larger. This causes that it is printed onto the transfer ribbon in the previous printout.

#### Example

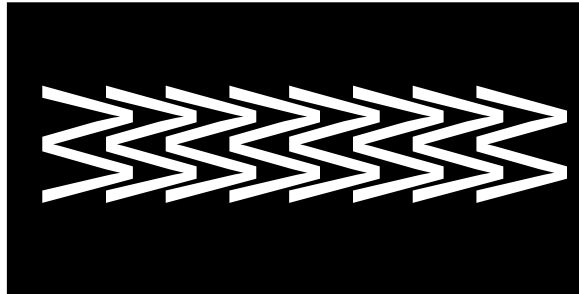



Press key  to arrive at the next menu item.

```
sa/mm cmin so/mm
303 1000 10
```

**Performance information:**

**sa/mm:** The smallest possible distance of two prints with full ribbon save (the print offset must be set to the minimum value). As basis for the calculation the set ribbon save parameters are used, as well as mode and especially the indicated max. print speed.

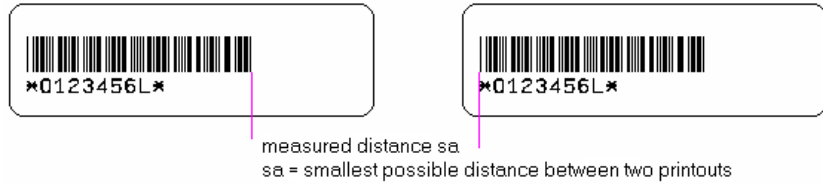

**cmin:** Max. number of cycles per minute.

**so/mm:** Indicates the loss of ribbon save, i.e. how many mm transfer ribbon is effectively lost.



Press key  to arrive at the next menu item.

```
ExpertParameters
```

**ExpertParameters:**

This menu item is password protected. Enter password, press key  to confirm the input and the following parameters are indicated:

```
PhDownT REStartT
30 ms 10 ms
```

**PhDownT = printhead down time in ms:**

This is used from ribbon save algorithm for the calculation of start time of printhead upwards movement.

**REStartT = ribbon motor early start time in ms:**

This value is added to the increase time of transfer ribbon movement. Time indication for the time between 'motor reached material speed' and 'printhead burns'.

If the same value is entered as for PhDownT, the printhead upwards movement is not started before the transfer ribbon motor reached the material speed.

Press key  to arrive at the next menu item.

```
MinSpeed Calcoff
50 mm/s On
```

**MinSpeed = minimal print speed:**

If the min. print speed is increased, the max. number of cycles is also increased.

**Calcoff = Turn On/Off print offset border calculation:**

If this parameter is set to Off, then a smaller offset as the required print offset can be entered.

Press key  to arrive at the next menu item.

```
PhUpT PhVReactT
 20 ms   10 ms
```

**PHupT = printhead up time in ms:**

Is used from ribbon save algorithm to calculate if a field ribbon save can be made or not.

**PhVReactT = valve reaction time in ms:**

It is calculated when the printhead upwards movement is started.

Press key  to arrive at the next menu item.

```
RibMotStpDlayT
  2 ms
```

**RibMotStpDlayT = ribbon motor stop delay time**

Deceleration time in ms in which the transfer ribbon motor is still moved with constant speed before stopping.

This can be used to correct black bars at the end of print or to provide a longer cooling for the printhead.

Press key  to arrive at the next menu item.

```
FieldRS Rwind v
Normal  600mm/s
```

**FieldRS = field ribbon saving:**

**Off:** Field ribbon save mode Off.

**PHOnly:** Only the printhead is moved. The transfer ribbon is not stopped.

**Normal:** Field ribbon save is executed only if the transfer ribbon motor is completely stopped.

**Strong:** Field ribbon save is executed, even if the transfer ribbon motor is not stopped.

**Rwind v = rewind speed in mm/s:**

Indication of rewind in mm/s.

Press key  to arrive at the next menu item.

```
Speed 1. Field
 400 mm/s
```

**Speed 1. Field:**

If 0 (default value) is set, the parameter has no influence to the ribbon save. Otherwise the ribbon save algorithm does not use the measured speed for the calculation of layout ribbon save but the speed that is indicated here.

Press key  to arrive at the next menu item.

```
Tension
  0 mm
```

**Tension:**

Indication of length, which is transported forward after measuring the transfer ribbon.

### 13.3 Shift ribbon save (continuous mode)

Press key **F** to access the function menu.

Press key **▲** as long as you arrive at the 'Ribbon save' menu.

```
Function Menu
Ribbon Save
```

Press key **●** to select the menu.

```
Mode      Speed
Shift     600
```

Press key **▼** and **▲** to select the ribbon save mode 'Shift'.

Press key **▲** to arrive at the following menu item.

```
X-Shift  Y-Shift
10 mm    13 mm
```

#### X-Shift and Y-Shift

##### X-Shift:

Indication of displacement of the printout in X direction. The printout can be displaced by the entry of a positive or negative value in both directions.

##### Y-Shift:

Indication of displacement of the printout in printing direction. Enter value 0 in order to achieve a print result in which the columns are arranged side by side on the transfer ribbon.

Press key  to arrive at the next menu item.

Lanes 3  
R-Shift -5 mm

**Lanes / R-Shift**

**Lanes:**

Indication of number of lanes printed side by side.

**R-Shift:**

Indication of distance when changing to a new lane.

**Example**

X-Shift: 2 mm; Y-Shift: -3 mm  
Lanes: 2; R-Shift: -5

X-Shift: 2 mm; Y-Shift: -3 mm  
Lanes: 2; R-Shift: +3 mm

**Layout**



**Transfer ribbon**

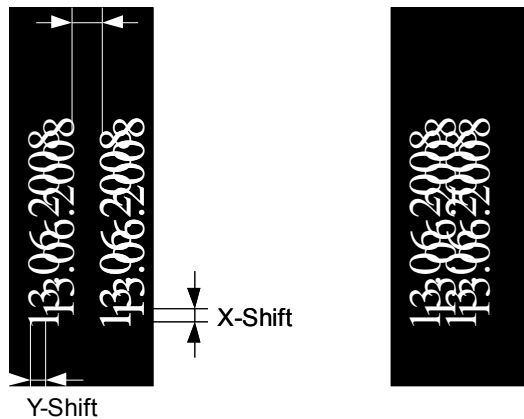

**Print result**

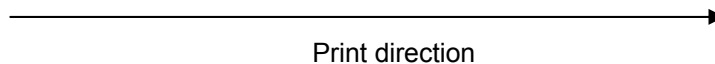
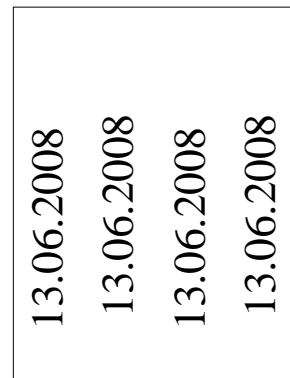
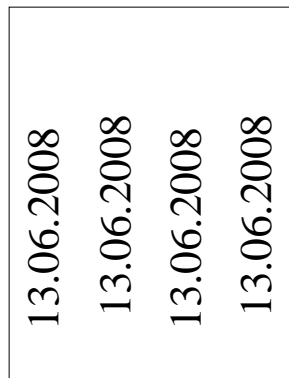

**Example  
Lanes printing**

X-Shift: 0 mm; Y-Shift: -10 mm; Lanes: 2; R-Shift: 0 mm

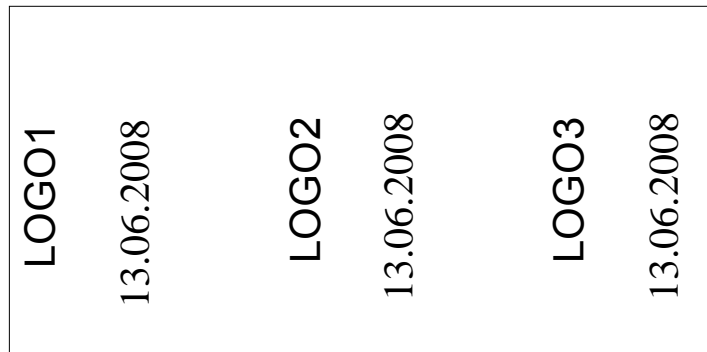
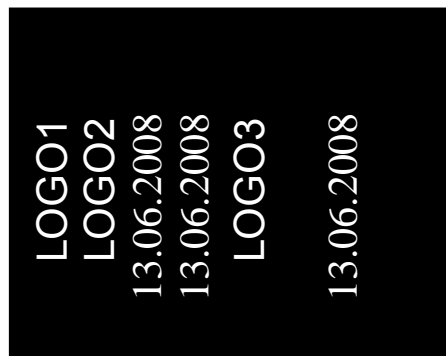
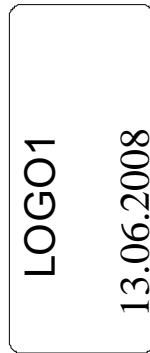

Supposed that the print speed is so high that no field ribbon save is possible, but after a lane enough time is available then by means of the shift ribbon save the gap of the fields can be filled with suitable layouts

Press key  to arrive at the next menu item.

**ExpertParameters**

**ExpertParameters:**

This menu item is password protected. Enter password, press key  to confirm the input.

Please find the description of ExpertParameters in chapter 13.2, page 102).

### 13.4 SaveStrt ribbon save (continuous mode)

Press key **F** to access the function menu.

Press key **▲** as long as you arrive at the 'Ribbon save' menu.



```
Function Menu
Ribbon Save
```

Press key **●** to select the menu.

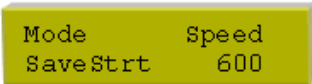

```
Mode      Speed
SaveStrt  600
```

Press key **▼** and **▲** to select the ribbon save mode 'SaveStrt'.

Press key **▲** to arrive at the next menu item.



```
ExpertParameters
```

**ExpertParameters:**

This menu item is password protected. Enter password and press key **●** to confirm the input.

Please find the description of Experten Parameters in chapter 13.2, page 102).

### 13.5 Standard ribbon save (intermittent mode)

Press key **F** to access the function menu.

Press key **▶** as long as you arrive at the 'Ribbon save' menu.

Function Menu  
Ribbon Save

Press key **●** to select the menu.

Mode  
Standard

Press key **▼** and **▲** to select the ribbon save mode 'Standard'.

Press key **▶** to arrive at the following menu item.

R-Correction  
-1 mm

#### R-Correction

Please find the description of the function in chapter 13.2, page 102.

Press key **▶** to arrive at the next menu item.

ExpertParameters

#### ExpertParameters:

This menu item is password protected. Enter password, press key **●** to confirm the input and the following parameters are indicated:

PhDownT    PhUpT  
35 ms      0 ms

#### PhDownT = printhead down time in ms:

Is used from the ribbon save algorithm to calculate the start of the printhead downwards movement.

#### PhUpT = printhead up time in ms:

Is used from the ribbon save algorithm to calculate if a field ribbon save is possible or not.

Press key **▶** to arrive at the next menu item.

PhVReactT  
10 ms

#### PhVReactT = valve reaction time in ms:

The time is calculated when the printhead upwards movement is started.

Press key **▶** to arrive at the next menu item.

Tension RM  
0 mm      0

#### Tension / Ribbon Mode

**Tension:** Indication of length that is transported forwards after measuring the transfer ribbon.

#### Ribbon Mode:

**0:** The transfer ribbon is retracted after each printout over the complete print length, i.e. no ribbon save between the individual layouts.

**1:** The transfer ribbon is only retracted over the printed sector, i.e. the gaps between the layouts were not optimised.

When changing the layouts, the transfer ribbon is positioned automatically.

### 13.6 Shift ribbon save (intermittent mode)



Press key **F** to access the function menu.

Press key  as long as you arrive at the 'Ribbon save' menu.

Function Menu  
Ribbon Save

Press key  to select the menu.

Mode  
Shift

Press key  and  to select the ribbon save mode 'Shift'.

Press key  to access the following menu item.

X-Shift    Y-Shift  
10 mm    13 mm

#### X-Shift / Y-Shift

Please find the description of the function in chapter 13.3, page 105.

Press key  to arrive at the next menu item.

Lanes    R-Shift  
3        -5 mm

#### Lanes / R-Shift

Please find the description of the function in chapter 13.3, page 105.

Press key  to arrive at the next menu item.

ExpertParameters

#### ExpertParameters:

This menu item is password protected. Enter password and press key  to confirm the input.

Please find the description of ExpertParameters in chapter 13.5, page 109.



## 14 Index

### C

Cable space .....	31
Column printing .....	97
Compact Flash card .....	71, 72, 73, 74
Connection .....	34
Continuous mode	
Material speed .....	8
Print principle .....	8
Contiuous mode	
Material guiding .....	8

### D

Delivery scope .....	29
Display indications during printing.....	69

### E

Encoder, pin assignment.....	28
Environmentally-friendly disposal.....	6
Error messages/Error corrections .....	87, 88, 89, 90, 91, 92, 93, 94, 95

### F

Figures.....	6, 7
Function menu	
Date/time .....	63
Device settings .....	57, 58
Emulation.....	62
I/O parameters.....	59
Interface.....	61
Layout settings.....	54
Machine parameters (continuous mode).....	50, 51
Machine parameters (intermittent mode).....	52, 53
Network.....	60
Print settings .....	49
Remote console .....	60
Ribbon save (continuous mode).....	55
Ribbon save (intermittent mode) .....	56
Service functions .....	64, 65, 66

### H

Hotstart .....	100, 101
----------------	----------

### I

Important notes .....	5
Initiation .....	35

Initiation, preparations .....	34
Inputs/outputs .....	18, 19, 20, 21, 22, 23, 24, 25, 26
Installation at machines .....	30
Intended use .....	5
Intermittent mode, print position .....	9
Intermittent mode, print principle .....	9

## K

### Keyboard

Customized mode .....	42
Standard mode .....	41
Text entry/customized entry .....	43

## M

Main menu .....	67, 68
Maintenance/cleaning	
Angle adjustment .....	77
Cycle optimisation (intermittent mode) .....	79
Print quality optimisation .....	78
Printhead, cleaning .....	75
Printhead, replacing .....	75, 76
Menu structure	
Continuous mode .....	45, 46
Intermittent mode .....	47, 48

## O

Operating conditions .....	13, 14, 15, 16
----------------------------	----------------

## P

Password protection .....	98, 99
Plug & Play .....	27
Pneumatic power supply, connection .....	32
Pressure power, adjusting .....	33
Print control .....	35

## R

### Ribbon cassette, insert

Coating inside .....	38
Coating outside .....	37
Increasing clamping force (ribbon roll) .....	39

## S

Safety Instructions .....	11, 12
Safety notes .....	11, 12
Signal diagrams	
Continuous mode .....	81, 82, 83, 84
Intermittent mode .....	85, 86

**T**  
Technical data ..... 17

**U**  
Unpacking..... 29

**W**  
Warnings ..... 12



---

Carl Valentin GmbH  
Neckarstraße 78 – 86 u. 94 . 78056 Villingen-Schwenningen  
Phone +49 (0)7720 9712-0 . Fax +49 (0)7720 9712-9901  
info@carl-valentin.de . www.carl-valentin.de