

MS7820 Solaris™

Metrologic's MS7820 Solaris vertical mini-slot scanner increases productivity with an unmatched feature set that aggressively scans high-density codes and fits easily into any existing enclosure found in small-item, high-volume retail environments.

Designed to increase system output and lower the total cost of ownership, the MS7820 reduces on-site service costs and downtime in convenience, drug, specialty, liquor, and grocery store environments.

With an extended depth of field and advanced decoding software, cashiers can scan all standard bar codes on the first pass with minimal concern for orientation or print quality.

Multiple on-board interfaces make the MS7820 compatible with most POS systems, while automatic detection of the interface cable expedites system configuration. The MS7820 further simplifies integration by drawing power directly from the host's 12-volt USB or serial port.

Unlike other comparable devices, the MS7820 includes a troubleshooting visual diagnostic indicator and the capability to perform remote Flash upgrades or software configurations. For investment protection, every scanner comes standard with an integrated RF EAS antenna and the capability to perform interlock with either Checkpoint or Sensormatic systems.

The MS7820 sets itself apart from the field with a multifunctional RS232 auxiliary port that provides a single point of communication for either a hand-held scanner or external scale.

Metrologic offers the MS7820 with one of two optional flex-pole stands for countertop or wall-mounted applications. For harsh checkout environments, the MS7820 provides an optional reinforced protective window.

www.metrologic.com/MS7820

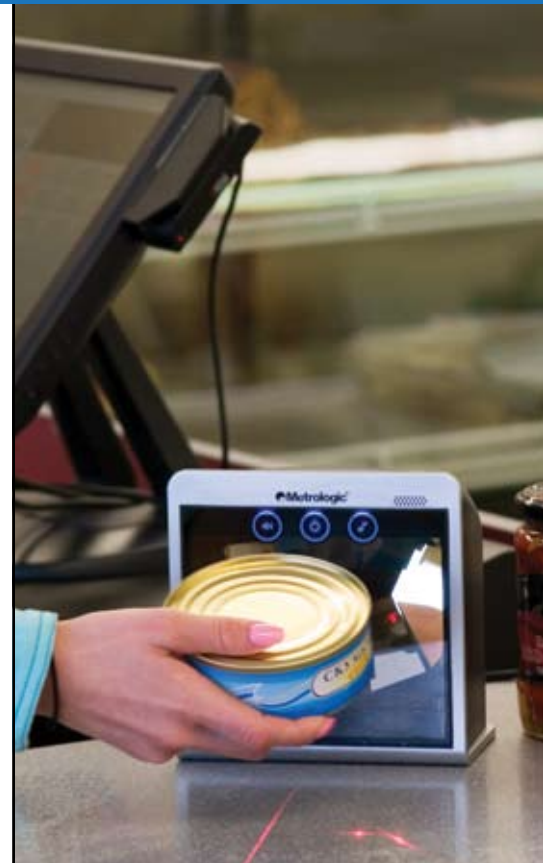

Features

- Reads 5.0 mil bar codes
- Multiple interfaces
- Diagnostic indicator
- Remote configuration and Flash upgrade
- Draws power from host through USB or serial ports (12 V)

Benefits

- Aggressively decodes high-density bar codes and optimizes checkout procedures
- Provides infrastructure protection and ensures compatibility with most POS systems
- Enables fast and easy troubleshooting and decreases downtime
- Eliminates on-site service expenses, reducing the total cost of ownership
- Saves space and money by reducing the number of cables

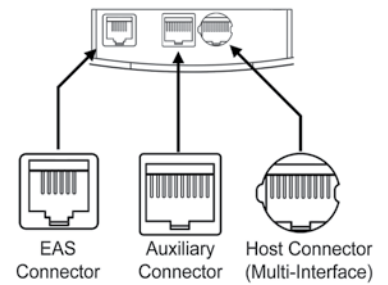
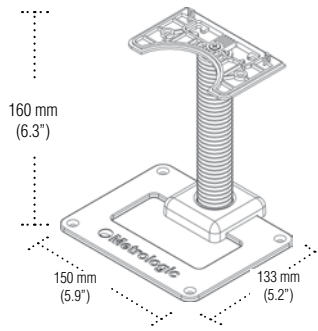
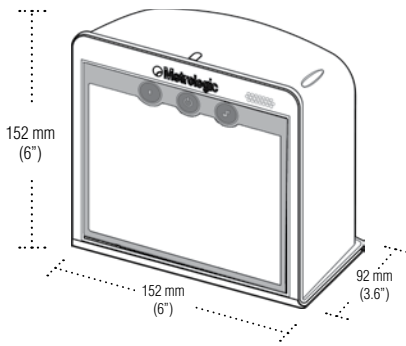

OPERATIONAL

Light Source	Visible laser diode 650 nm ± 10 nm
Laser Power	0.900 mW (peak)
Decode Capability	Auto-discriminates all standard bar codes, including GS1 DataBar™; for other symbologies call Metrologic
System Interfaces	RS232, Keyboard wedge, USB, IBM 468x/469x
Number Characters Read	Up to 80 data characters
Beeper Operation	7 tones or no beep
Indicators (LED)	Blue = unit powered, ready to scan; Blue flash = good read, button activation; 7-segment display = failure diagnostic

MECHANICAL

Dimensions (without stand)	152 mm (6.0") H x 152 mm (6.0") W x 92 mm (3.6") D
Footprint of stand	150 mm (5.9") x 133 mm (5.2")
Weight	0.7 kg (1.56 lbs)
Termination	Two 10-pin modular RJ45 jacks, One 6-pin modular RJ45 jack
Cable	Standard 2.9m (9.5') straight; for other cables call Metrologic

ELECTRICAL

Input Voltage	12 VDC ± 0.25 V
Power	3.8 W; 4.8 W (with AUX handheld scanner)
Operating Current	320 mA; 400 mA (with AUX handheld scanner)
DC Transformers	Class II; 12 VDC @ 1.25 A
Laser Class	IEC 60825-1:1993+A1+A2:EN60825-1:1994+A1+A2
EMC	FCC part 15, IEC-003, CISPR 22, EN55022 Class B

ENVIRONMENTAL

Operating Temperature	0°C to 40°C (32°F to 104°F)
Storage Temperature	-40°C to 60°C (-40°F to 140°F)
Humidity	5% to 95% relative humidity, non-condensing
Light Levels	Up to 4842 Lux (450 foot candles)

SCAN PERFORMANCE

Depth of Scan Field	0 mm – 255 mm (0" – 10") for 0.33 mm (13 mil) bar code
Width of Scan Field	100 mm (4") @ 0 mm; 323 mm (12.7") @ 255 mm (10.0")
Scan Speed	1800 scan lines per second
Scan Pattern	5 fields of 4 parallel lines (omnidirectional)
Minimum Bar Width	5 mil (0.127 mm)
Print Contrast	35% minimum reflectance difference
Pitch, Yaw	360°, 60°, 60°

Scan Area

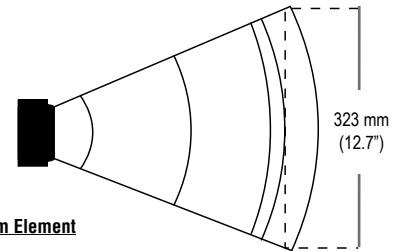

Bar Code Minimum Element

- 0.132 mm (5.2 mil)
- 0.191 mm (7.5 mil)
- 0.264 mm (10.4 mil)
- 0.330 mm (13 mil)
- 0.660 mm (26 mil)

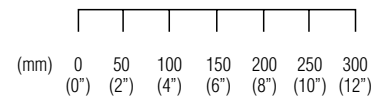

Product Colors Available



MS7820 is available in a variety of other colors with minimum quantity purchase.



Metrologic Instruments, Inc. | Worldwide Headquarters
 90 Coles Road | Blackwood, NJ 08012-4683 | info@metrologic.com
 Telephone 856-228-8100 | Fax 856-228-6673 | www.metrologic.com

Asian Headquarters Tel. 65.6842.7155 info@sg.metrologic.com
European Headquarters Tel. 49.89.89019.0 info@eu.metrologic.com
The Americas Headquarters Tel. 1.800.ID.METRO info@us.metrologic.com



Specifications subject to change without notice. Printed U.S.A Copyright January 2008 Metrologic, all rights reserved.



DS7820



About BarcodesInc

Who We Are

BarcodesInc is North America's leading provider of... [The following text is intentionally obscured with noise for this block]

We Owe Our Success To You

Our success is due to the support of our customers... [The following text is intentionally obscured with noise for this block]

Why Choose BarcodesInc?

Dedicated Account A UbU Yf

Our Account Managers will not compromise when it comes to providing you top-notch service. Your Account Manager is the primary point of contact for your business and makes it a priority to get to know you, your company and all your needs.

Highly-Trained Technical Support

Our technical staff has the broadest knowledge and every significant certification in the industry. One of our friendly experts is always available to suggest products and solutions for any situation.

Incredible Value

Our purchasing power means big savings for you. Whatever your project, our team will work hard to deliver a solution that fits your budget.

Largest Inventory in the Industry and Same-Day Shipping

Whatever your barcoding, mobile computing, or printing needs, we will fill your order and ship it the same day.

Premier Access to Top Manufacturers

BarcodesInc maintains strong strategic partnerships with the leading manufacturers in barcoding, mobile computing, printing and RFID.

Responsive Customer Service

Every phone call and email is responded to promptly, completely and accurately by our customer service team.

Easy Returns

Damaged, defective or incorrectly ordered goods may be returned without hassle.

BRANDS



AND MORE