

HP R/T2200 UPS User Guide



Part Number 404314-004
August 2008 (Fourth Edition)

© Copyright 2006, 2008 Hewlett-Packard Development Company, L.P.

The information contained herein is subject to change without notice. The only warranties for HP products and services are set forth in the express warranty statements accompanying such products and services. Nothing herein should be construed as constituting an additional warranty. HP shall not be liable for technical or editorial errors or omissions contained herein.

Intended audience

This guide is for the person who operates, configures, maintains, and troubleshoots UPSs. HP assumes you are qualified in the servicing of high-voltage equipment and trained in recognizing hazards in products with hazardous energy levels.

Contents

Component identification	6
UPS front panel	6
UPS front panel controls and LED indicators	7
UPS R/T2200 NA/JPN/TWN rear panel	8
UPS R/T2200 INTL rear panel	9
REPO port	10
Installation	12
Precautions	12
Preparing to install the hardware	12
Required tools	12
Selecting a site	12
Readying the equipment	13
Installing the UPS as a tower	13
Installing the UPS in a rack	15
Connecting the batteries	18
Selecting the UPS voltage configuration	19
Connecting the host computer	20
Connecting the UPS to utility power	23
Connecting devices to the UPS	23
Charging the UPS batteries	24
Powering up the UPS	24
Installing the ERM as a tower	24
Installing the ERM in a rack	25
Connecting the ERM to the UPS	28
Attaching the RETMA rail covers	28
Charging the ERM batteries	29
UPS operations	30
Initiating a self-test	30
Silencing an audible alarm	30
Audible alarm conditions	30
Setting the power sensitivity adjustment dial	30
Powering down the UPS	31
Power management	32
Power management software	32
Maintenance	33
Updating the UPS firmware	33
Replacing the batteries	33
Important battery safety information	33
Battery care and storage guidelines	34
UPS battery replacement procedure	34
Cleaning battery spills	36
Troubleshooting	37
UPS does not start	37

UPS does not communicate with the host computer	37
UPS firmware updating process is interrupted	37
Audible alarm sounds	37
Circuit breaker trips	37
UPS operates on battery only	37
UPS frequently switches between utility and battery power.....	38
UPS does not provide the expected backup time	38
UPS emits a slight clicking noise.....	38
Power LED flashes	38
Voltage Configuration LED is green	39
Output Load Level LED is red or flashing red	39
Battery Charge LED is red.....	39
Specifications	40
UPS physical specifications.....	40
ERM physical specifications	40
UPS input specifications	40
UPS output specifications.....	40
Power protection specifications	41
Voltage specifications	41
Output tolerance specifications.....	41
Output feature specifications	41
Battery specifications	41
Battery runtime.....	42
Environmental specifications	42
Spares.....	43
Ordering spares.....	43
Spare parts list.....	43
Hardware options	43
Technical support.....	44
Before you contact HP.....	44
HP contact information.....	44
Warranty information.....	45
Limited warranty	45
\$250,000 Computer Load Protection Guarantee.....	45
Pre-Failure Battery Warranty	45
Regulatory compliance notices	46
Regulatory compliance identification numbers.....	46
Federal Communications Commission notice.....	46
FCC rating label.....	46
Class A equipment.....	46
Class B equipment	46
Declaration of conformity for products marked with the FCC logo, United States only.....	47
Modifications.....	47
Cables.....	47
Canadian notice (Avis Canadien).....	48
European Union regulatory notice	48
Disposal of waste equipment by users in private households in the European Union.....	48
Japanese notice	49
BSMI notice	49
Korean notice	49

Battery replacement notice.....	50
Power cord statement for Japan.....	50
Electrostatic discharge	51
Preventing electrostatic discharge	51
Grounding methods to prevent electrostatic discharge.....	51
Acronyms and abbreviations.....	52
Index.....	53

Component identification

UPS front panel

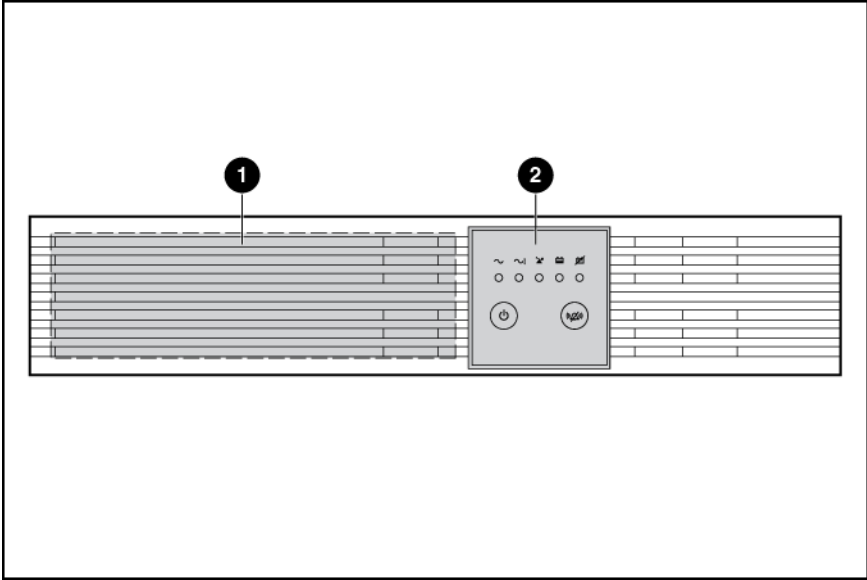

Item	Description
1	Battery compartment
2	Control buttons and LED display

UPS front panel controls and LED indicators

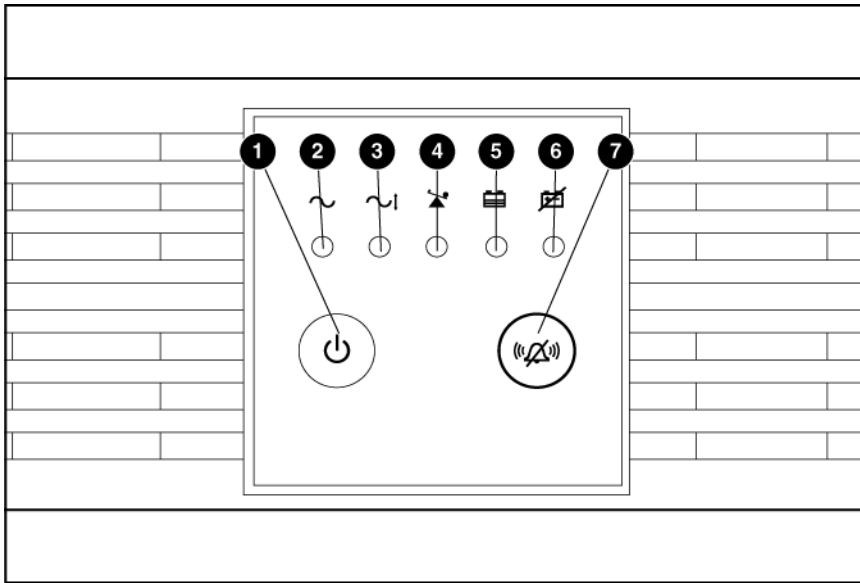

Item	Description	Function
1	Power On/Standby button	Turns the UPS power on and off, and places the UPS in Standby mode. ¹
2	Power LED	Green—The UPS is on and supplying connected equipment with AC power. Flashing green—The UPS is operating from its internal batteries during a blackout or severe brownout. If the blackout or brownout is prolonged, save any open files and shut down the connected equipment.
3	Voltage Correction LED	Green—The UPS is automatically correcting high or low AC voltage on the utility line without the assistance of battery power. The UPS will emit a slight clicking noise.
4	Output Load Level LED	Shows approximately how much of the UPS power capacity is used to support the equipment connected to the output receptacles. Red—Maximum load Amber—Medium load Green—Light load

Item	Description	Function
5	Battery Charge LED	<p>When the UPS is operating from utility power (the Power LED is green), the Battery Charge LED indicates the approximate charge state of the batteries:</p> <ul style="list-style-type: none"> • Red—The batteries are beginning to charge. • Amber—The batteries are midway through charging. • Green—The batteries are fully charged. <p>When the UPS is operating on battery power during a blackout or severe brownout (the Power LED is flashing green), the Battery Charge LED indicates the approximate amount of remaining battery energy:</p> <ul style="list-style-type: none"> • Red—The batteries have a low level of energy. • Amber—The batteries have a medium amount of energy. • Green—The batteries have a high amount of energy. <p>Periodically initiate a self-test ("Initiating a self-test" on page 30) to determine the energy level of the batteries before a blackout or brownout occurs.</p>
6	Battery Warning LED	Red—During a self-test, the UPS found that the batteries must be recharged. Charge the batteries and repeat the self-test (" Initiating a self-test " on page 30).
7	Mute/Test button	Silences UPS alarms and initiates a self-test (" Initiating a self-test " on page 30).



IMPORTANT: While in Standby mode, the UPS maintains the charge on the batteries, but no power is available at the output receptacles. The UPS remains in Standby mode until an alternate mode is selected or until utility power is removed.

UPS R/T2200 NA/JPN/TWN rear panel

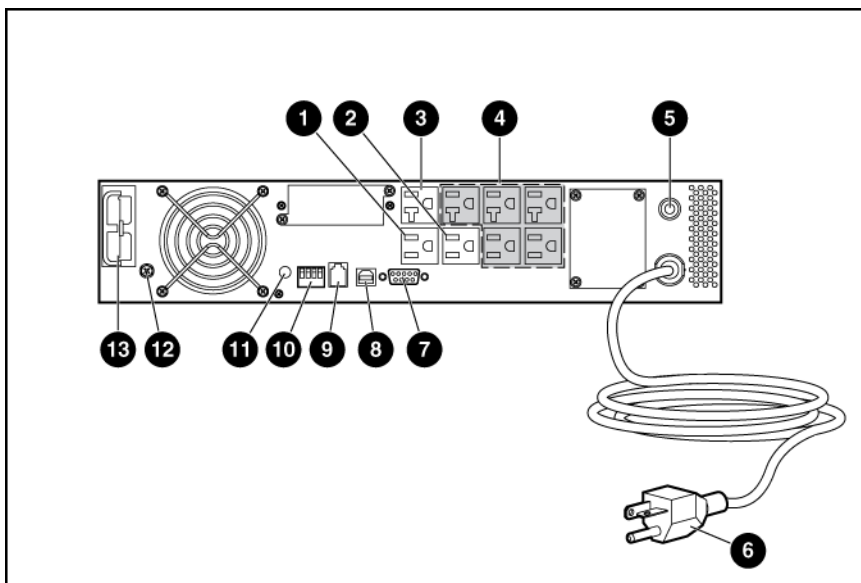

Item	Description
1	Load segment 1 (one NEMA 5-15 output receptacle for surge and battery backup protection)
2	Load segment 2 (one NEMA 5-15 output receptacle for surge and battery backup protection)
3	Load segment 3 (one NEMA 5-20 output receptacle for surge and battery backup protection)
4	Load segment 4 (five unswitchable NEMA 5-15/20 output receptacles for surge and battery backup protection)
5	Input circuit breaker
6	Input power cord with NEMA 5-20 plug
7	Serial communications port
8	USB communications port
9	REPO port
10	Voltage configuration and charge rate DIP switches
11	Power sensitivity adjustment dial
12	Ground bonding screw
13	ERM connector

For information about controlling load segments remotely, see "Power management software (on page 32)."

UPS R/T2200 INTL rear panel

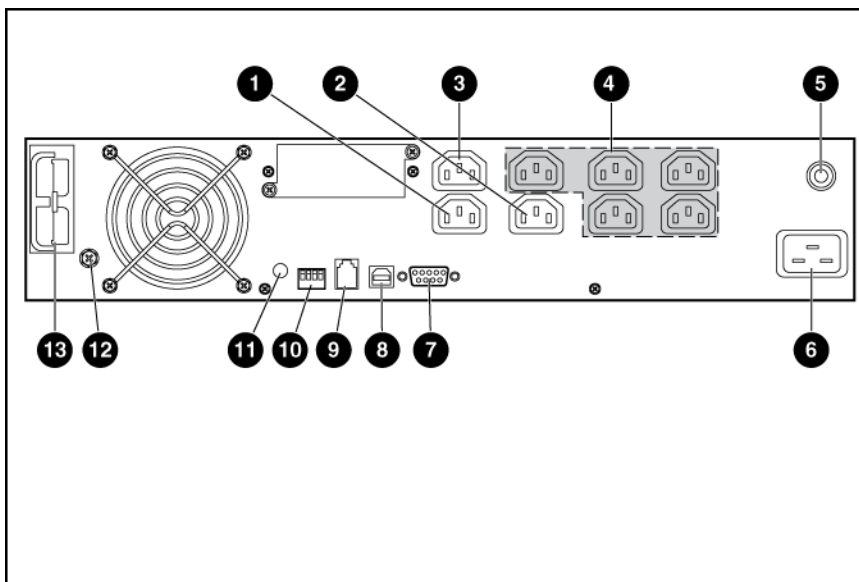

Item	Description
1	Load segment 1 (one IEC-320-C13 output receptacle for surge and battery backup protection)
2	Load segment 2 (one IEC-320-C13 output receptacle for surge and battery backup protection)

Item	Description
3	Load segment 3 (one IEC-320-C13 output receptacle for surge and battery backup protection)
4	Load segment 4 (five unswitchable IEC-320-C13 output receptacles for surge and battery backup protection)
5	Input circuit breaker
6	Input power cord with IEC-320-C20 plug
7	Serial communications port
8	USB communications port
9	REPO port
10	Voltage configuration and charge rate DIP switches
11	Power sensitivity adjustment dial
12	Ground bonding screw
13	ERM connector

For information about controlling load segments remotely, see "Power management software (on page 32)."

REPO port

The UPS includes an RJ-11 type EPO port. The EPO function can be used to power down the UPS output receptacles in an emergency. This feature is enabled by utilizing a normally open (N.O.) switch (option 1) or a normally closed (N.C.) switch (option 2). The EPO port is referred to as a REPO port when used in conjunction with a remote main disconnect device that shuts down utility power in an emergency.

Option 1: User supplied normally open switch

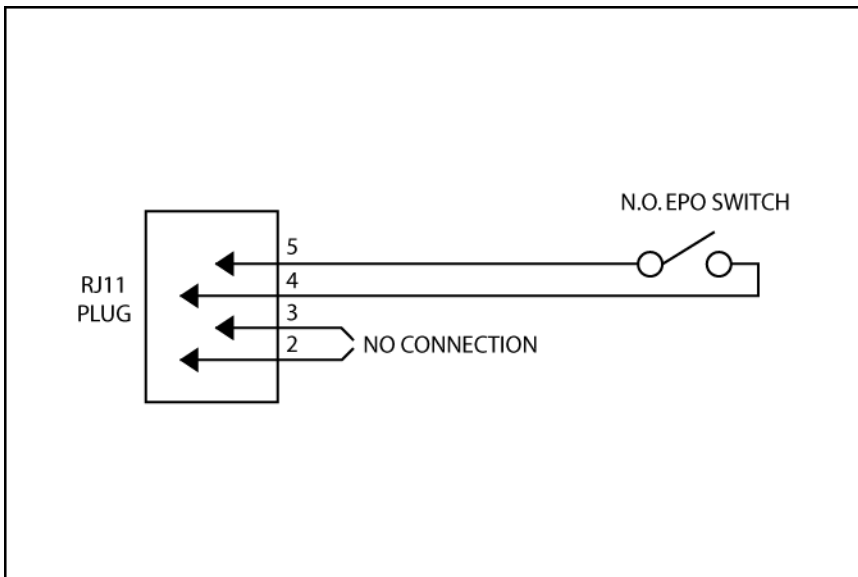

When the switch is enabled:

- The REPO feature immediately powers down protected devices and does not utilize the orderly shutdown procedure initiated by power management software.

- The REPO feature shuts down UPS units operating under either utility or battery power.

Option 2: User supplied normally closed switch

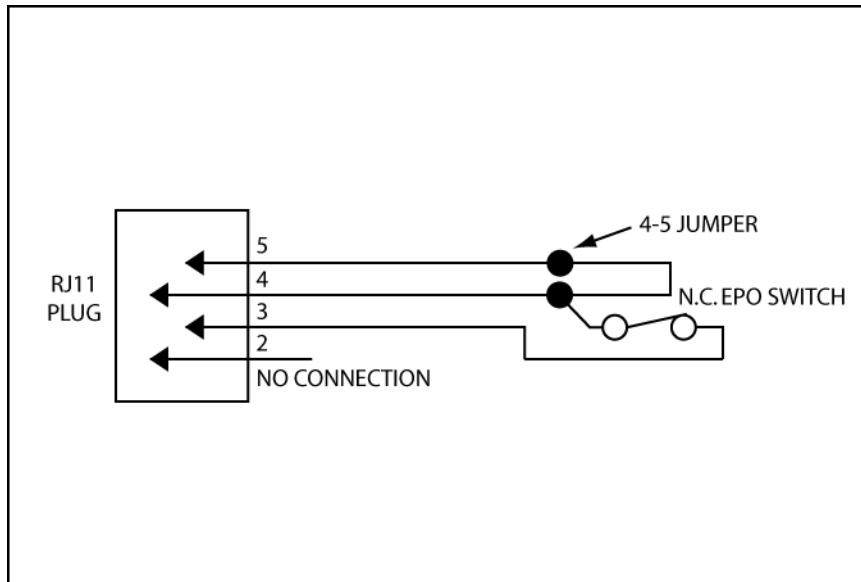

NOTE: If the UPS was operating on battery power when the remote switch was closed, no power is available to the load devices until utility power is restored and the UPS has been manually powered up.

To restore power to the load devices after the REPO feature is activated, press the Power On/Standby button after the AC source is reconnected to the UPS.



IMPORTANT: Pressing and holding the Power On/Standby button without utility present normally initiates a battery start and the UPS assumes the load. However, if the Power On/Standby button is pressed and a REPO is detected, battery start is inhibited and the UPS is not able to assume the load.

To power down the entire network in the event of an emergency, the REPO ports of multiple UPS units can be connected to a single switch.

Installation

Precautions

Save these instructions. This document contains important safety instructions that should be followed during installation, operation, and maintenance of the UPS and batteries.

-
-  **WARNING:** A risk of personal injury from electric shock and hazardous energy levels exists. The installation of options and routine maintenance and service of this product must be performed by individuals who are knowledgeable about the procedures, precautions, and hazards associated with AC power products.

 -  **WARNING:** To prevent personal injury from earth conductor leakage current:
 - Do not operate the UPS while disconnected from the utility power source.
 - Disconnect load devices before disconnecting the UPS from the utility power source.

 -  **WARNING:** To prevent personal injury, prepare the area and observe all materials handling procedures when transporting the UPS. When fully assembled, the UPS weighs 29 kg (64 lb).

 -  **WARNING:** To prevent personal injury, prepare the area and observe all materials handling procedures when transporting the ERM. When fully assembled, the ERM weighs 28.6 kg (63 lb).
-

Preparing to install the hardware

Before installing the hardware:

1. Be sure the necessary tools and materials ("[Required tools](#)" on page 12) are available.
2. Select an installation site ("[Selecting a site](#)" on page 12).
3. Prepare the equipment ("[Readying the equipment](#)" on page 13) for installation in the rack.

Required tools

- No. 2 Phillips screwdriver
- T-20 Torx screwdriver

Selecting a site

-
-  **WARNING:** To prevent fire or electric shock, install the unit in a temperature- and humidity-controlled indoor environment, free of conductive contaminants.
-

When selecting a site, consider the following factors:

- Elevated operating ambient temperature—If the equipment is installed in a closed or multi-unit rack assembly, the operating ambient temperature of the rack environment might be greater than room ambient temperature. Install the equipment in an environment compatible with the operating temperature ("[Environmental specifications](#)" on page 42).
- Reduced air flow—In the rack, the rate of air flow required for safe operation of the equipment must not be compromised.
- Circuit overloading—Consideration should be given to the connection of the equipment to the supply circuit and the effect that overloading of the circuits might have on overcurrent protection and supply wiring. Appropriate consideration of equipment nameplate ratings should be used when addressing this concern.
- Reliable earthing—Reliable earthing of rack-mounted equipment should be maintained. Particular attention should be given to supply connections other than direct connections to the branch circuit, such as the use of power strips.
- Electrical requirements—All models require a dedicated (unshared) branch circuit, suitably rated for the specific UPS as stated in "Input specifications ("[UPS input specifications](#)" on page 40)" .

Readying the equipment

1. Check the battery recharge date specified on the label that is affixed to the shipping carton.



IMPORTANT: Do not use the battery if the recharge date has passed. If the date on the battery recharge date label has passed without the battery being recharged, contact an HP authorized service representative for directions.

2. Transport the packaged unit to its installation location.
3. Unpack the equipment near the rack where the unit will be assembled.



CAUTION: Always plan the rack installation so that the heaviest item is on the bottom of the rack. Install the heaviest item first, and continue to populate the rack from the bottom to the top.

Installing the UPS as a tower

Before installing the unit, review and adhere to all warnings provided in "Precautions (on page 12)."

1. Remove the UPS front bezel.

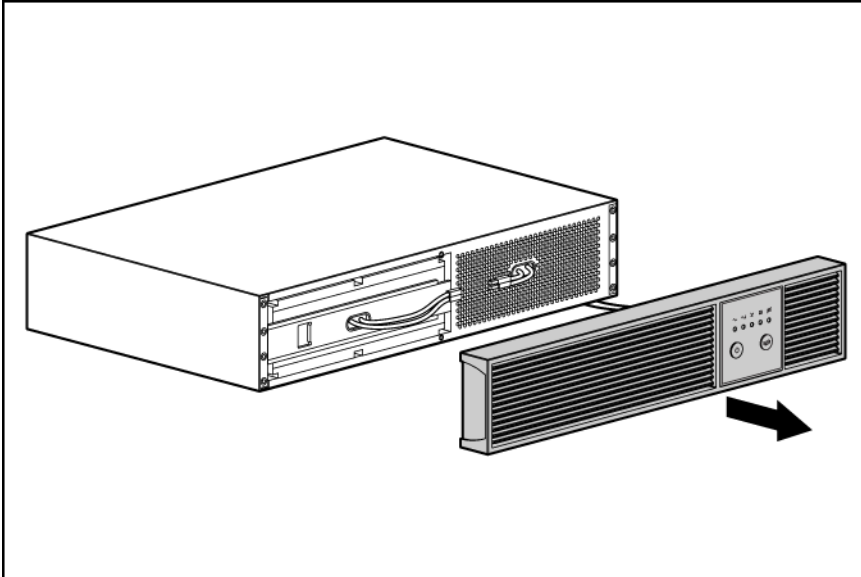

2. Attach the logo badge above the LED/Control panel.

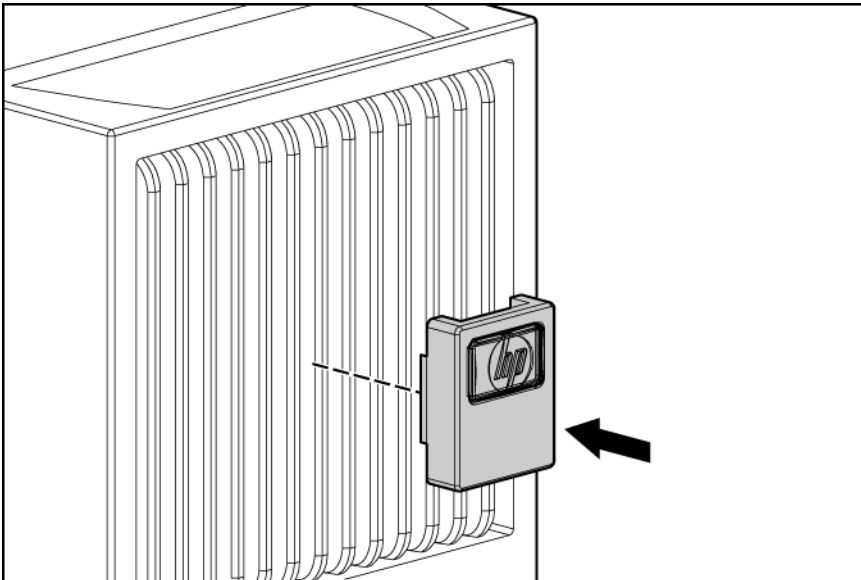

3. From inside the bezel, gently push out the LED/Control panel, rotate it 90 degrees, and then replace it in the bezel.

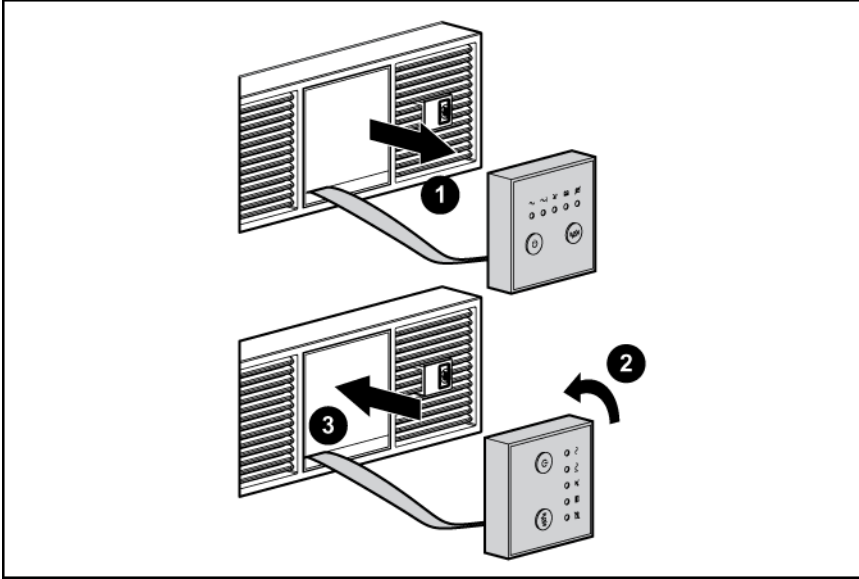

4. Replace the front bezel.
5. Stand the unit on its side with the LED/Control panel at the top.

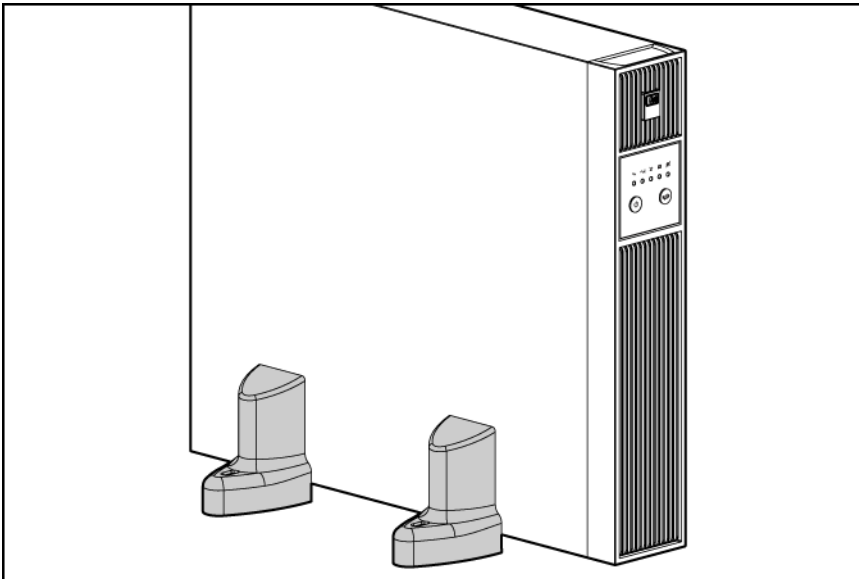

Installing the UPS in a rack

Before installing the unit, review and adhere to all warnings provided in "Precautions (on page 12)."



WARNING: To reduce the risk of personal injury or damage to the equipment, be sure that:

- The leveling feet are extended to the floor.
- The full weight of the rack rests on the leveling feet.
- The stabilizing feet are attached to the rack if it is a single-rack installation.
- The racks are coupled together in multiple-rack installations.
- Only one component is extended at a time. A rack may become unstable if more than one component is extended for any reason.

NOTE: Mounting hardware for square- and round-holed racks is included in the UPS kit.

1. Attach the 2U side-mounting brackets to the unit.

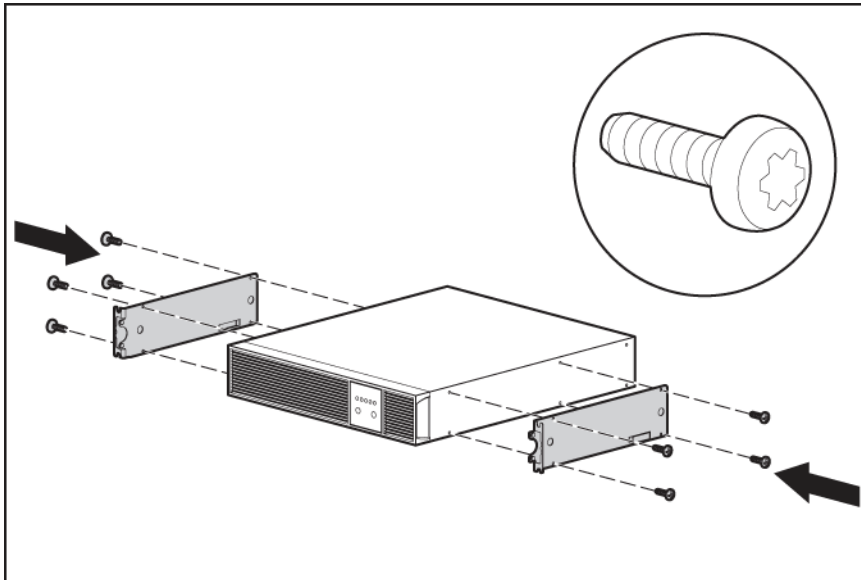

2. Loosen the wing nuts, and extend the brackets to the desired length.

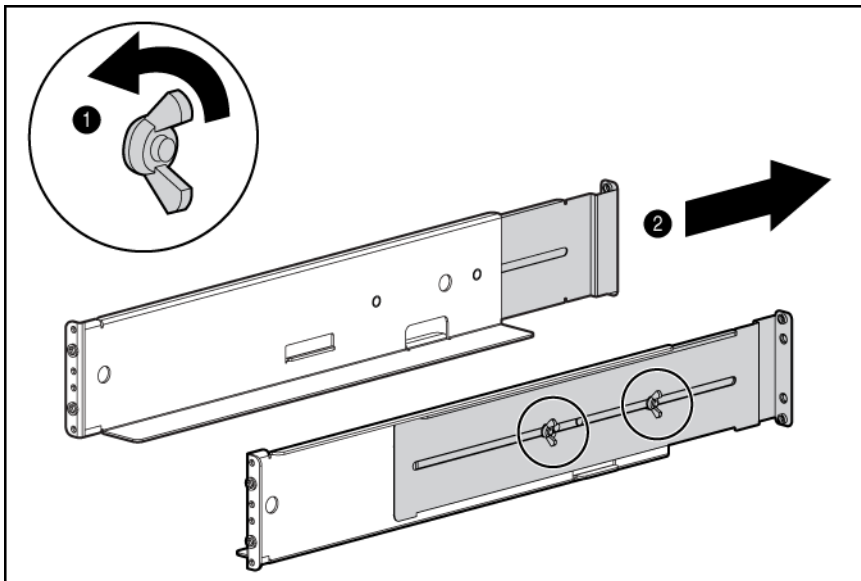

3. Insert screws through the rack into the mounting rail and the front of each mounting bracket. Do not completely tighten the screws.

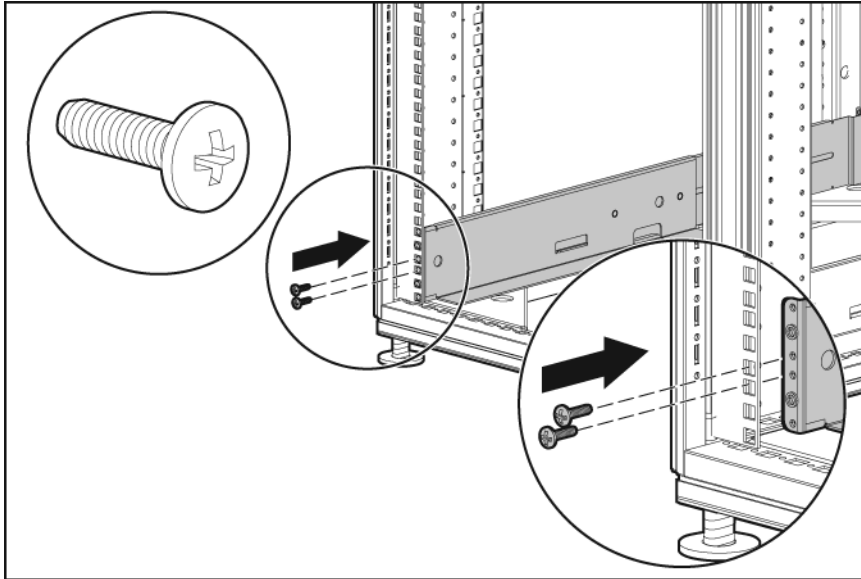

4. Insert screws through the rack into the mounting rail and the rear of each mounting bracket. Do not completely tighten the screws.

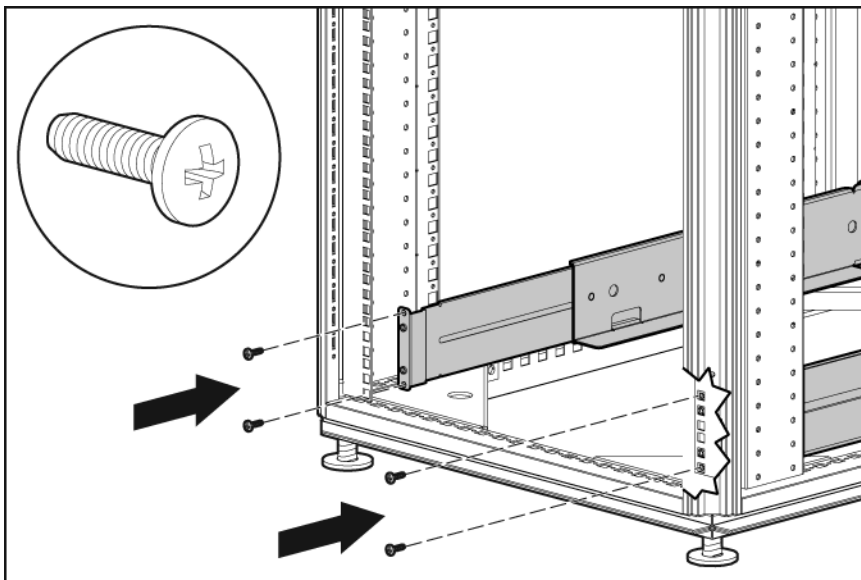

5. Wait until the unit is installed and the brackets are adjusted before tightening the screws.
6. Tighten the wing nuts.

⚠ WARNING: Uneven mechanical loading in the rack may cause a hazardous condition

⚠ CAUTION: Always plan the rack installation so that the heaviest item is on the bottom of the rack. Install the heaviest item first, and continue to populate the rack from the bottom to the top.

7. With one person on each side, lift the chassis to rail level and slide the chassis on the mounting rails.
8. Attach the chassis to the rack using the supplied screws.

Connecting the batteries



WARNING: The unit contains sealed lead-acid battery modules. To prevent fire or chemical burns:

- Do not attempt to recharge batteries after removal from the unit.
- Do not disassemble, crush, or puncture the batteries.
- Do not short the external contacts of the batteries.
- Do not immerse the batteries in water.
- Do not expose to temperatures higher than 40°C (104°F).



WARNING: To prevent personal injury from hazardous energy:

- Remove watches, rings, or other metal objects.
- Use tools with insulated handles.
- Do not place tools or metal parts on top of batteries.



IMPORTANT: Before performing the following tasks, be sure that the unit is powered down and disconnected from the utility power source.

1. Remove the UPS front bezel.

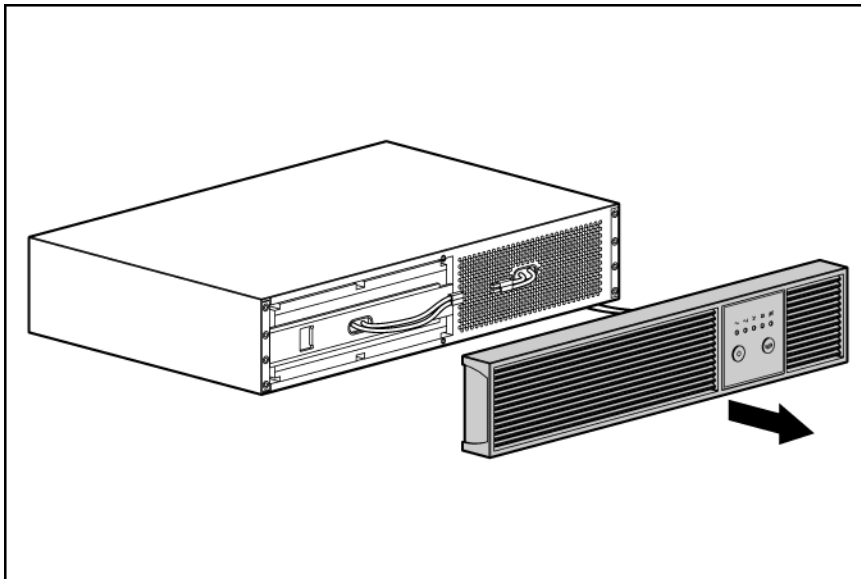

2. Connect the battery lead to the battery terminal.

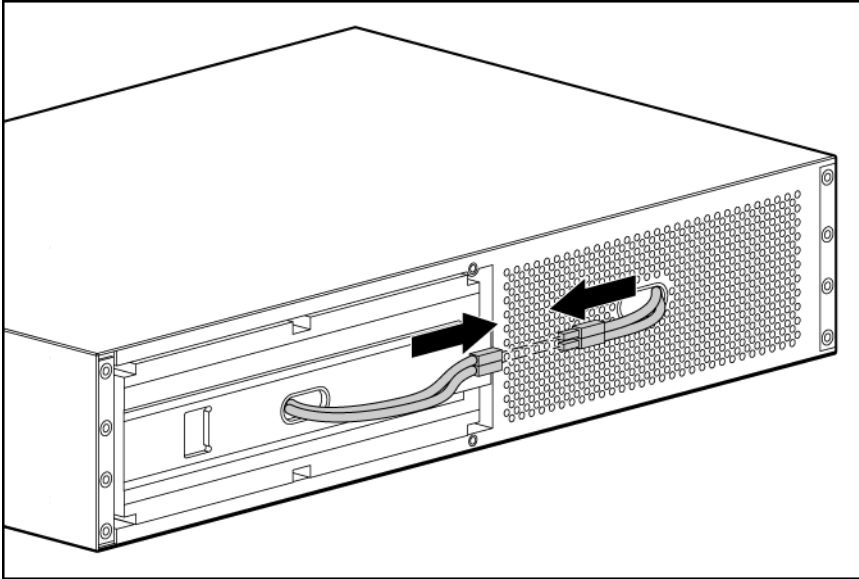

NOTE: A small amount of arcing may occur when connecting the batteries. This is normal and does not damage the unit or present any safety concern.

3. Replace the UPS front bezel.
4. Attach the RETMA rail covers.

NOTE: The HP logo and product name are printed on the RETMA rail covers; therefore, the HP logo badge is only used for a tower installation/configuration.

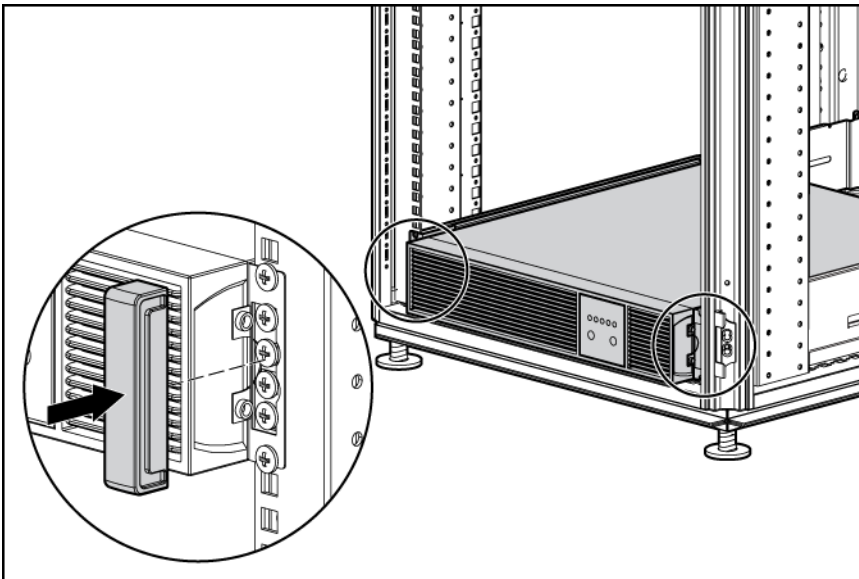

Selecting the UPS voltage configuration

Using a small tool, position the DIP switches according to the desired voltage configuration and charge rate as identified on the rear panel of the UPS and in the following table.

When using an ERM, set the Battery Charge Level switch (DIP switch 3) to the down position, increasing the UPS charger output and charging the ERM faster.

CAUTION: Do not set the Battery Charge Level switch to the down position without an ERM connected. There is a risk of damaging the internal battery system of the UPS.

NOTE: DIP switch 4 is inactive and does not affect UPS operation regardless of the position.

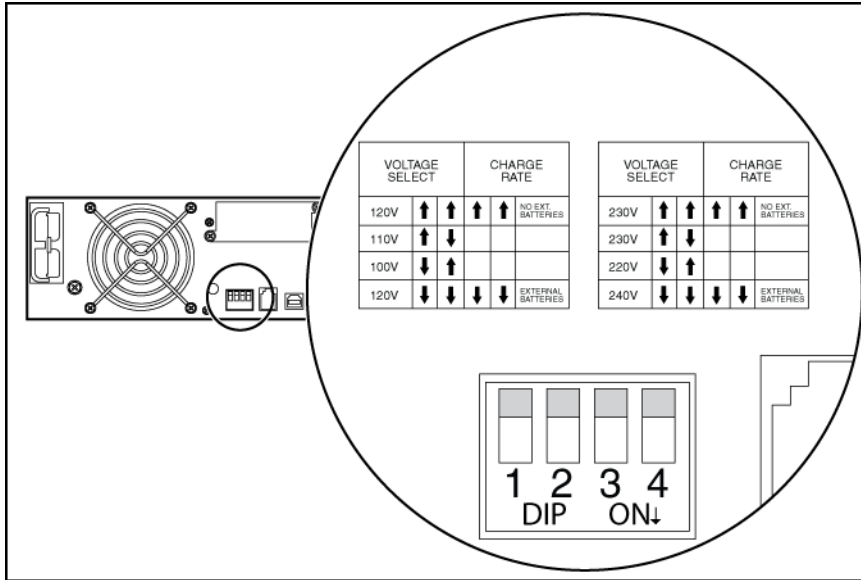

NOTE: An asterisk (*) indicates the default setting.

	Output voltage	Input voltage range	DIP switch 1	DIP switch 2	DIP switch 3	DIP switch 4
R/T2200 NA/JPN/TWN	120 V* (NA)	108–127 V	Up	Up	Up*	Up
	110 V	99–116 V	Up	Down	—	—
	100 V* (JPN/TWN)	90–106 V	Down	Up	—	—
	120 V	108–127 V	Down	Down	Down	Down
R/T2200 INTL	230 V	207–243 V	Up	Up	Up*	Up
	230 V* (INTL)	207–243 V	Up	Down	—	—
	220 V	198–233 V	Down	Up	—	—
	240 V	216–254 V	Down	Down	Down	Down

Connecting the host computer

⚠ **CAUTION:** Use only the computer interface cable supplied with the UPS to connect the communications port to the host computer.

⚠ **CAUTION:** Using a USB to serial converter cable will damage the UPS.

Connect the UPS to a host computer using either the USB cable or the DB9 serial cable included with the UPS. Install HP Power Manager software 4.1 or later on the host computer. See the HP website (<http://www.hp.com/go/rackandpower>) to download the latest version of HP Power Manager.

📄 **IMPORTANT:** If using HPPM, connect the Management Server to an unswitched output receptacle ("UPS R/T2200 INTL rear panel" on page 9, "UPS R/T2200 NA/JPN/TWN rear panel" on page 8), and then set the Management Server as the last device to shutdown, ensuring that all connected load devices are shutdown gracefully.

NOTE: To install and configure the software, see the software user guide. The software user guide is available for download from the HP website (<http://www.hp.com/go/rackandpower>).

Connecting the serial communications port

⚠ **CAUTION:** Use only the computer interface cable supplied with the UPS to connect the communications port to the host computer.

⚠ **CAUTION:** Using a USB to serial converter cable will damage the UPS.

📄 **IMPORTANT:** Power management software requires the communications port to be appropriately cabled to the host computer.

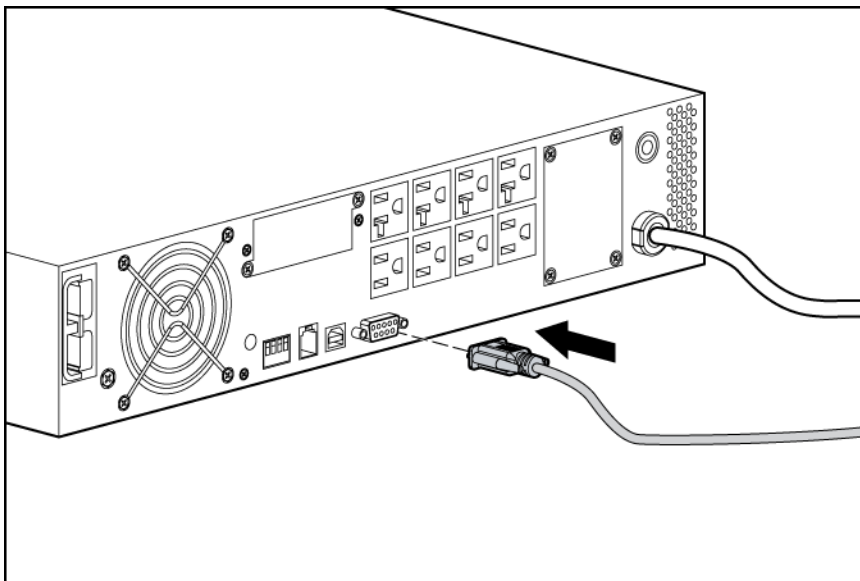

Connecting the USB communications port



CAUTION: Using a USB to serial converter cable will damage the UPS.

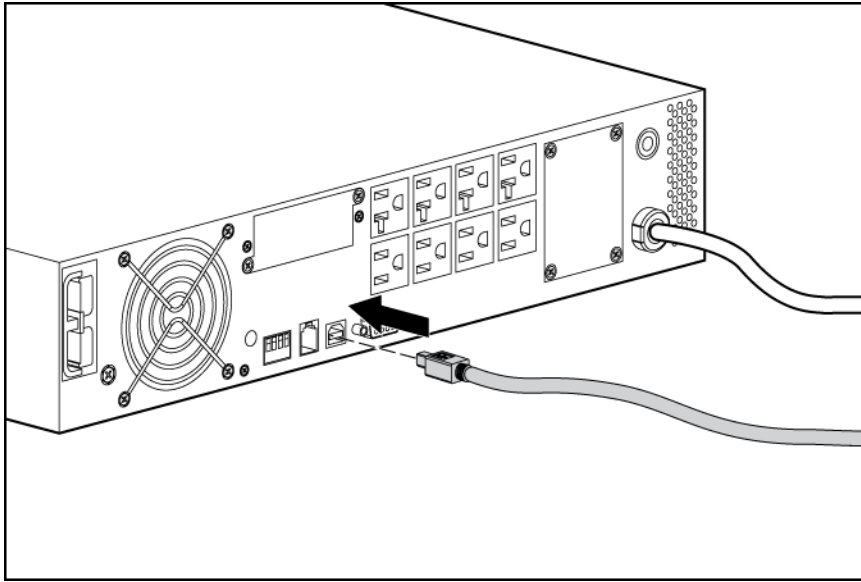

Connecting the REPO port



WARNING: To meet the requirements stated in NEC (NFPA 70) Articles 645-10 and 645-11, a UPS installed in a computer equipment room must be connected to a REPO circuit.



IMPORTANT: The remote switch must be in the Off (open) position to enable power to the output receptacles.

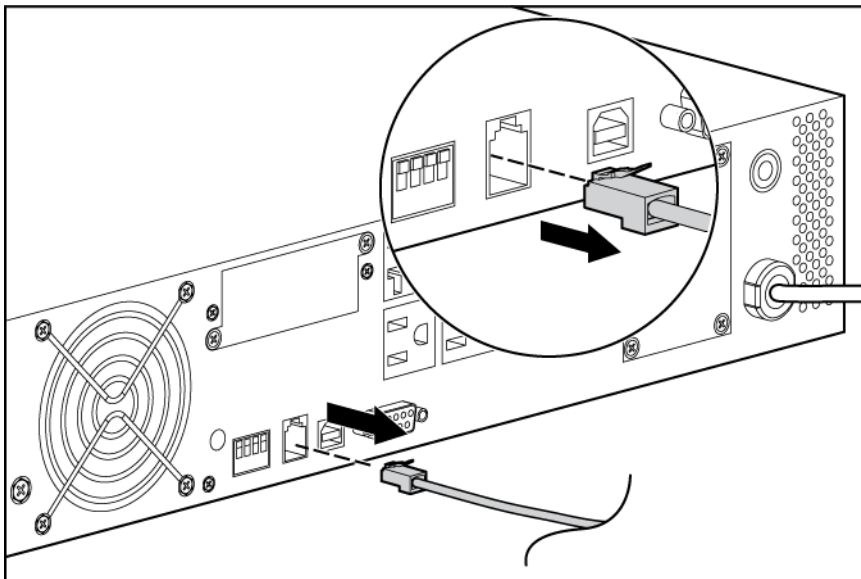

NOTE: Wire the connector block using stranded, nonshielded wire (AWG #22 - #18, or equivalent).

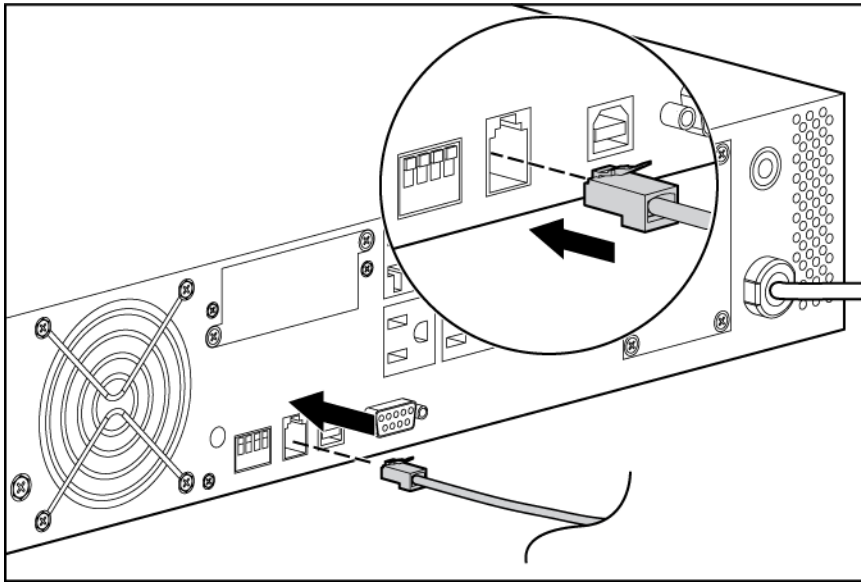

Connecting the ground bonding cable

The ground bonding screw is provided as an attachment point for conductors. Use a ground bonding cable if the rack contains any conductors for the purpose of functional grounding or bonding of ungrounded metal parts.

The ground bonding cable is not included.

Connecting the UPS to utility power



WARNING: To prevent injury from electric shock or damage to the equipment:

- Plug the input line cord into a grounded (earthed) electrical outlet that is installed near the equipment and is easily accessible.
- Do not disable the grounding plug on the input line cord. The grounding plug is an important safety feature.
- Do not use extension cords.

1. Connect the input power cord from an intended load device to the IEC-320-C20 input power receptacle on the UPS rear panel (INTL model only).
2. Connect the UPS power cord to a grounded utility power outlet. When the UPS is plugged in, the batteries begin to charge. Power to the output receptacles designated for surge and battery backup is not available until the unit is powered up.

For more information about receptacle control, see "Power management software (on page 32)".

Connecting devices to the UPS



CAUTION: Do not plug laser printers into the UPS output receptacles. The instantaneous current drawn by this type of printer can overload the UPS.

Before connecting devices, verify that the UPS will not overload by checking that the ratings of the devices do not exceed the UPS capacity. If the equipment rating is listed in amps, multiply the number of amps by 120 (for Japan, by 100) to determine the VA.

After verifying that the UPS will not overload:

- Connect the device power cords to the output receptacles on the rear panel of the UPS (NA/JPN/TWN model).
- or-
- Connect devices to the output receptacles on the rear panel of the UPS using the jumper cords included with the UPS (INTL model).

Charging the UPS batteries

Allow the batteries to charge before putting the UPS into service.



IMPORTANT: Charge the batteries for at least 24 hours before supplying backup power to devices. The batteries charge to:

- 90% of their capacity within 4 hours
- 100% of their capacity within 24 hours

Powering up the UPS

Press and hold the Power On/Standby button until the UPS beeps. The Power LED illuminates solid green, indicating that power is available at the UPS output receptacles.

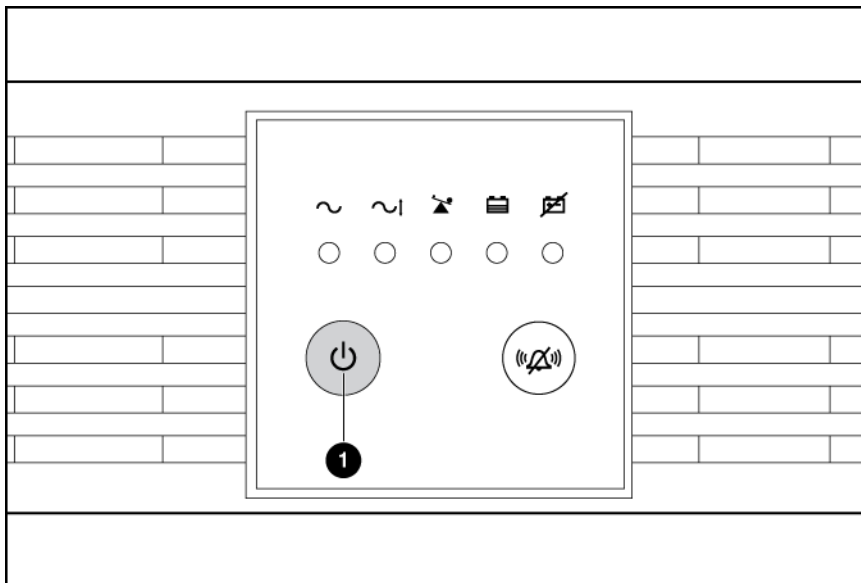

Installing the ERM as a tower

Before installing the unit, review and adhere to all warnings provided in "Precautions (on page 12)."

1. Attach the logo badge above the LED/Control panel.

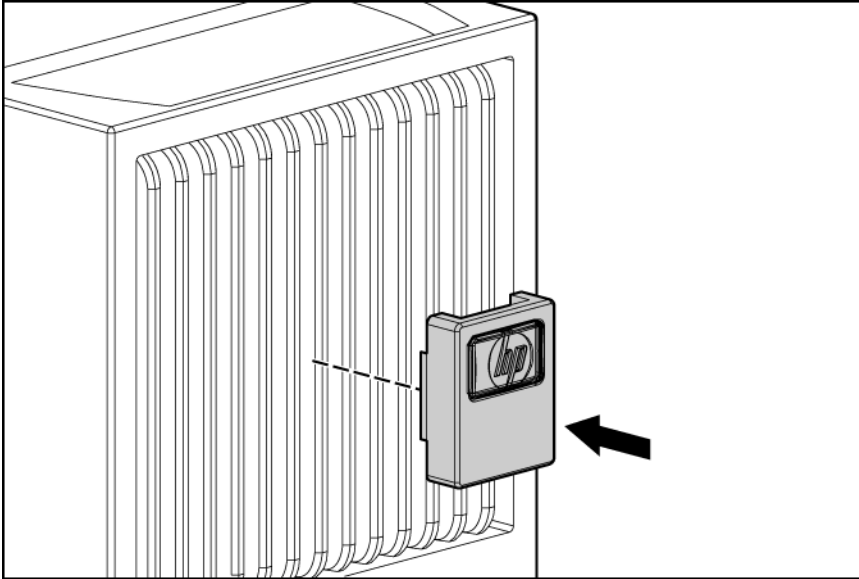

2. Stand the unit on its side with the LED/Control panel at the top.

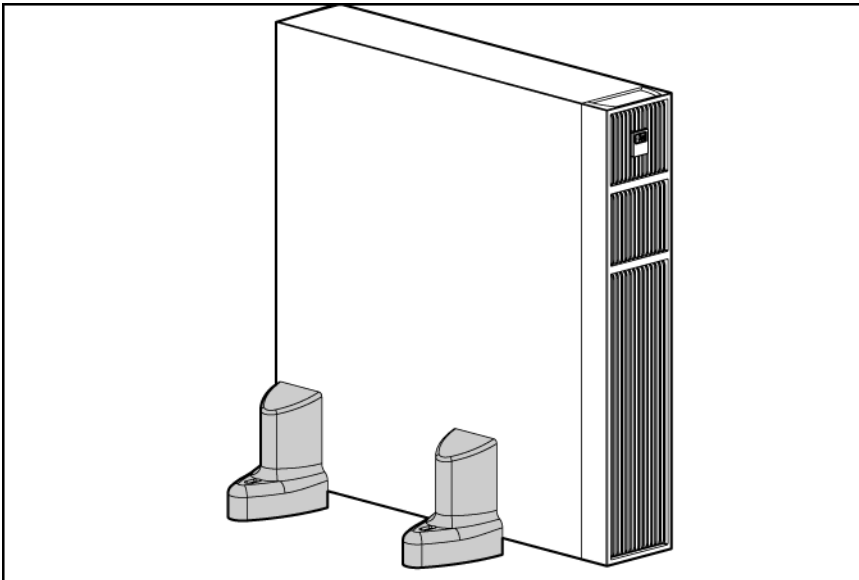

Installing the ERM in a rack

Before installing the unit, review and adhere to all warnings provided in "Precautions (on page 12)."



WARNING: To reduce the risk of personal injury or damage to the equipment, be sure that:

- The leveling feet are extended to the floor.
- The full weight of the rack rests on the leveling feet.
- The stabilizing feet are attached to the rack if it is a single-rack installation.
- The racks are coupled together in multiple-rack installations.
- Only one component is extended at a time. A rack may become unstable if more than one component is extended for any reason.

NOTE: Mounting hardware for square- and round-holed racks is included in the UPS kit.

1. Attach the 2U side-mounting brackets to the unit.

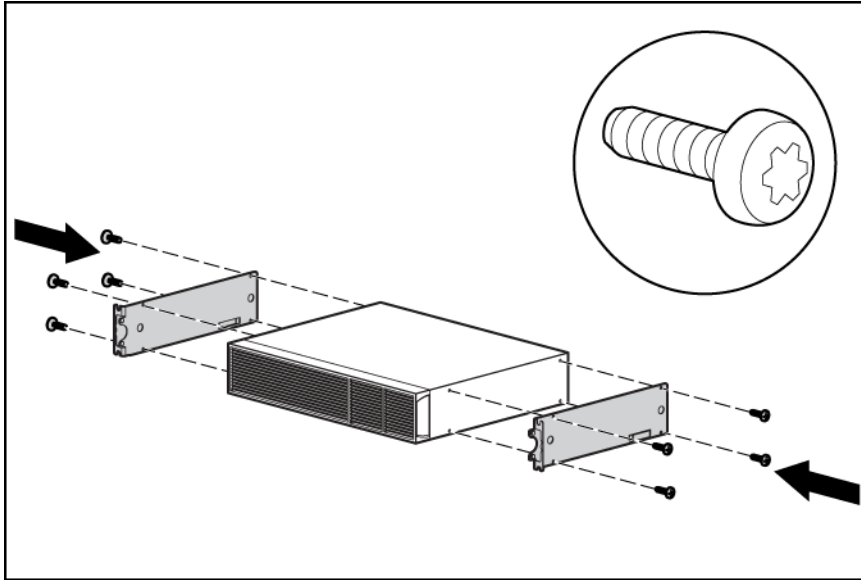

2. Loosen the wing nuts, and extend the brackets to the desired length.

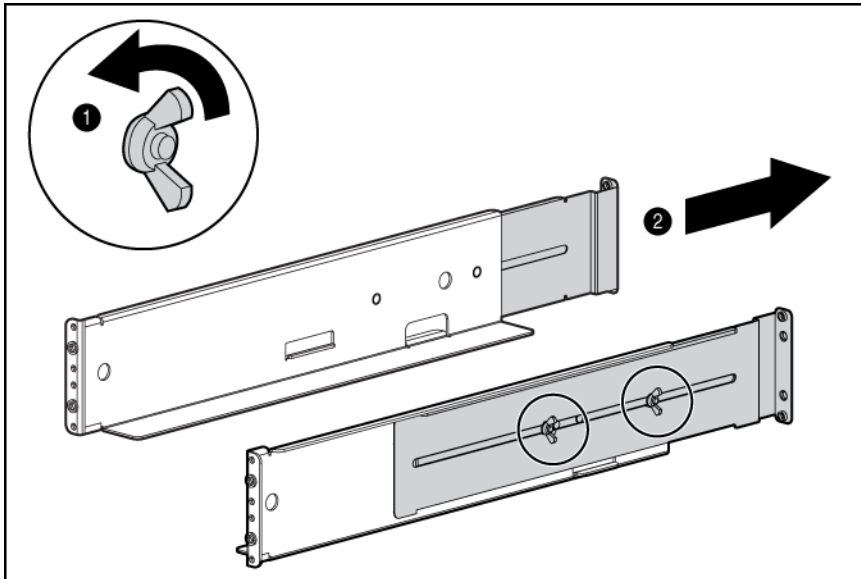

3. Insert screws through the rack into the mounting rail and the front of each mounting bracket. Do not tighten.

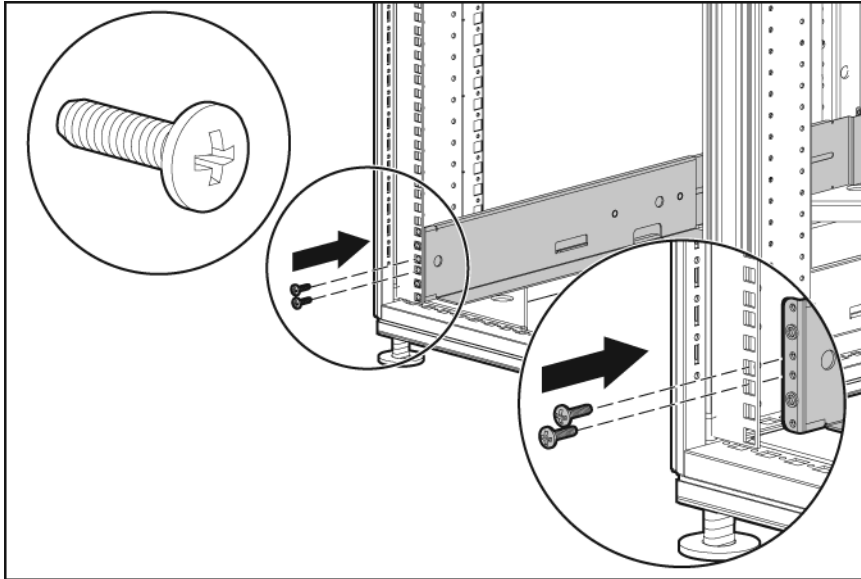

4. Insert screws through the rack into the mounting rail and the rear of each mounting bracket. Do not tighten.

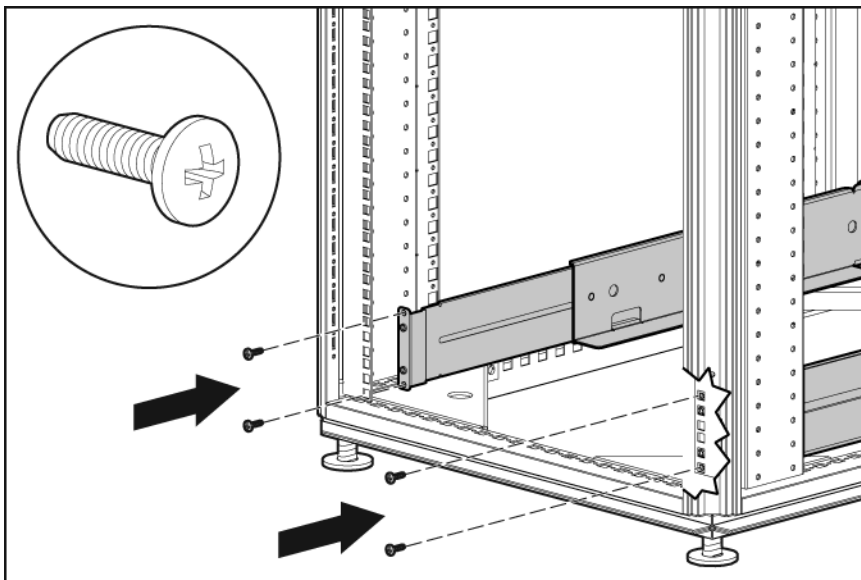

5. Tighten the wing nuts.
6. Wait until the unit is installed and the brackets are adjusted before tightening the screws.



WARNING: Uneven mechanical loading in the rack may cause a hazardous condition



CAUTION: Always plan the rack installation so that the heaviest item is on the bottom of the rack. Install the heaviest item first, and continue to populate the rack from the bottom to the top.

7. With one person on each side, lift the chassis to rail level and slide the chassis on the mounting rails.
8. Attach the chassis to the rack using the supplied screws.

Connecting the ERM to the UPS



This symbol indicates the presence of electric shock hazards. The area contains no user or field serviceable parts. Do not open for any reason.

WARNING: To reduce the risk of injury from electric shock hazards, do not open this enclosure.

Plug the ERM cable into the socket at the rear of the UPS.

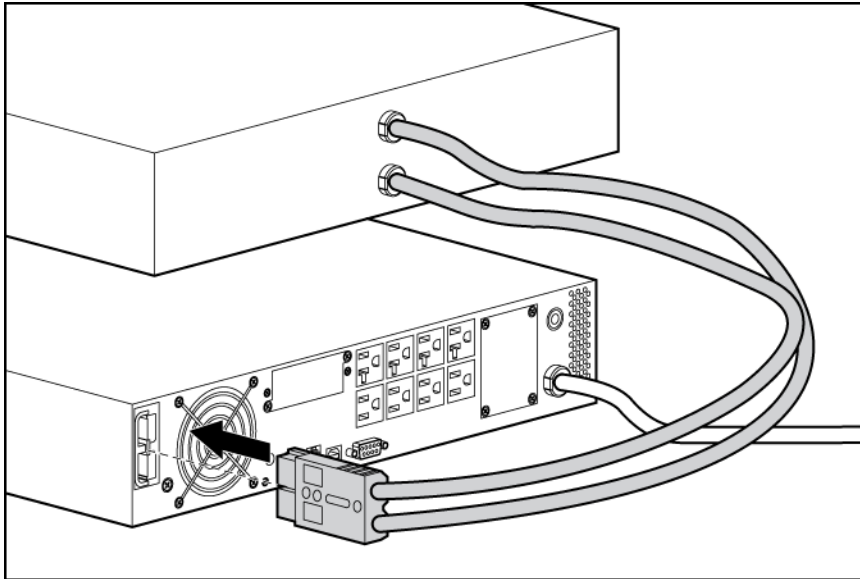

Attaching the RETMA rail covers

NOTE: The HP logo and product name are printed on the RETMA rail covers; therefore, the HP logo badge is only used for a tower installation/configuration.

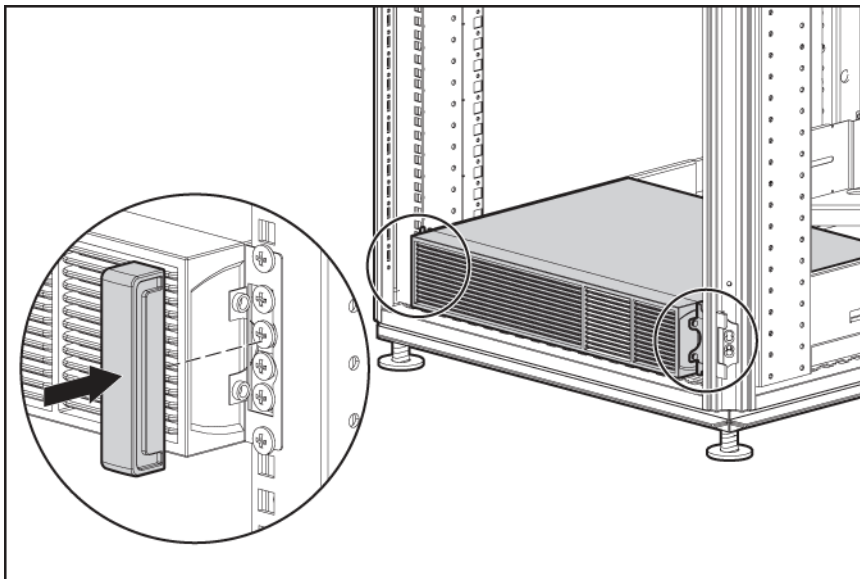

Charging the ERM batteries

Connect the UPS to a grounded utility power outlet. When the UPS is plugged in, the unit automatically enters Standby mode and begins charging the ERM batteries. Allow 24 hours for the ERM to fully charge.

UPS operations

Initiating a self-test

A self-test can be performed with equipment connected to the UPS output receptacles. To initiate a self-test, press and hold the Mute/Test button until the alarm beeps two times.



CAUTION: Do not unplug the UPS to test the batteries. This action removes safe electrical grounding and can introduce a damaging surge into the network connections.

The self-test lasts approximately 10 seconds as the UPS switches to battery power to test the load capacity and battery charge. During the self-test, the Power LED flashes, the Output Load Level LED illuminates, and the Battery Charge LED illuminates.

Silencing an audible alarm

Press the Mute/Test button.



IMPORTANT:

- Although the audible alarm silences, the condition that caused the alarm to sound might still exist.
- If a utility power failure caused the alarm (the Power LED is flashing green), the alarm silences after power is restored.

Audible alarm conditions

Alarm type	Condition	Audible alarm	Can alarm be silenced?
Normal	UPS operating from utility power	No audible alarm	N/A
UPS on battery	UPS operating on battery power	On–four short beeps	Yes
Shutdown imminent	Batteries nearly out of power	On–continuous	Yes
Battery problem	Batteries must be recharged	On–intermittent beeps	Yes
Overload	UPS power capacity exceeded	On–continuous	Yes

Setting the power sensitivity adjustment dial

The power sensitivity adjustment dial is normally set in the counter-clockwise position, enabling the UPS to provide maximum protection against waveform distortions in the AC input. When distortion occurs, the UPS provides sine wave power from the battery reserves for as long as the distortion is present. In areas with poor utility power or where the UPS input power comes from a backup generator, continuous waveform distortion causes the UPS to switch to battery power. To minimize battery use, experiment with

different settings for this dial. As the dial is turned clockwise, the UPS becomes more tolerant of variations in the input power's AC waveform.

NOTE: While testing, operate connected equipment in a safe test mode so the effects do not disrupt critical operations.

For the location of rear panel components, see "UPS R/T2200 NA/JPN/TWN rear panel (on page 8)" or "UPS R/T2200 INTL rear panel (on page 9)."

Powering down the UPS

1. Shut down all connected load devices.
2. Press the Power On/Standby button. Power to the output receptacles ceases.
3. Disconnect the UPS from utility power.
4. Wait at least 60 seconds for the UPS internal circuitry to discharge.

Power management

Power management software

HP Power Manager software ensures maximum power reliability of computer systems through comprehensive control of UPSs. The easy-to-use browser interface enables novice users to configure and manage power protection settings. To download the latest version of HP Power Manager software, see the HP website (<http://www.hp.com/go/rackandpower>).

NOTE: To install and configure the software, see the software user guide. The software user guide is available for download from the HP website (<http://www.hp.com/go/rackandpower>).

HP Power Manager:

- Does not require complex management systems, which simplifies deployment, configuration, and management of UPS-protected environments.
- Manages a graceful shutdown of attached devices during utility power failures.
- Prioritizes the timing of attached load device shutdowns.
- Shuts down and reboots any UPS and attached load devices based on a user-specified schedule.
- Customizes alert generation with modifiable dialog boxes, command execution, and email and broadcast messages.
- Monitors the status of the UPS and reports alarms.
- Displays a power log for analysis.
- Manages independent UPS load segments to provide separate control of attached load devices.

Maintenance

Updating the UPS firmware

To update the UPS firmware, see the HP website (<http://www.hp.com/go/rackandpower>).

 **CAUTION:** Using a USB to serial converter cable will damage the UPS.

NOTE: Be sure to disconnect the USB communications port before beginning the firmware update. Once the upgrade is complete, reconnect the USB communications port.

NOTE: If the firmware update process is disrupted by disconnecting the serial communications port, restart the update.

Replacing the batteries

To replace the batteries:

1. Read and observe the requirements in "Important battery safety information" and "Battery care and storage guidelines (on page 34)."
2. Follow the instructions in "UPS battery replacement procedure (on page 34)."

Important battery safety information

 **WARNING:** The unit contains sealed lead-acid battery modules. To prevent fire or chemical burns:

- Do not attempt to recharge batteries after removal from the unit.
- Do not disassemble, crush, or puncture the batteries.
- Do not short the external contacts of the batteries.
- Do not immerse the batteries in water.
- Do not expose to temperatures higher than 60°C (140°F).

 **WARNING:** To prevent personal injury from hazardous energy:

- Remove watches, rings, or other metal objects.
- Use tools with insulated handles.
- Do not place tools or metal parts on top of batteries.

NOTE: Replace all battery modules at the same time.

Battery care and storage guidelines

- △ **CAUTION:** Because of the short shelf life of the batteries, avoid storing a battery spare as a backup. Do not maintain an inventory of spare batteries on site unless a procedure to keep these batteries charged while in storage is implemented.

To maintain the batteries:

- Minimize the amount of time the UPS uses battery power by matching the UPS configuration with the utility voltage. See "Selecting the UPS voltage configuration (on page 19)."
- Keep the area around the UPS clean and dust-free. If the environment is very dusty, clean the outside of the UPS regularly with a vacuum cleaner.
- Maintain the ambient temperature at 25°C (77°F).
- If storing a UPS for an extended period, recharge the batteries ("Charging the UPS batteries" on page 24) every 6 months, and then update the battery recharge date label.

UPS battery replacement procedure

This component is hot-swappable and can be replaced without powering down the UPS.

1. (optional) To replace the component with the UPS powered down, refer to "Powering down the UPS (on page 31)."

- △ **CAUTION:** When hot-swapping batteries, the UPS is not protected in the event of a utility power failure, unless an ERM is installed.

2. Remove the UPS front bezel.

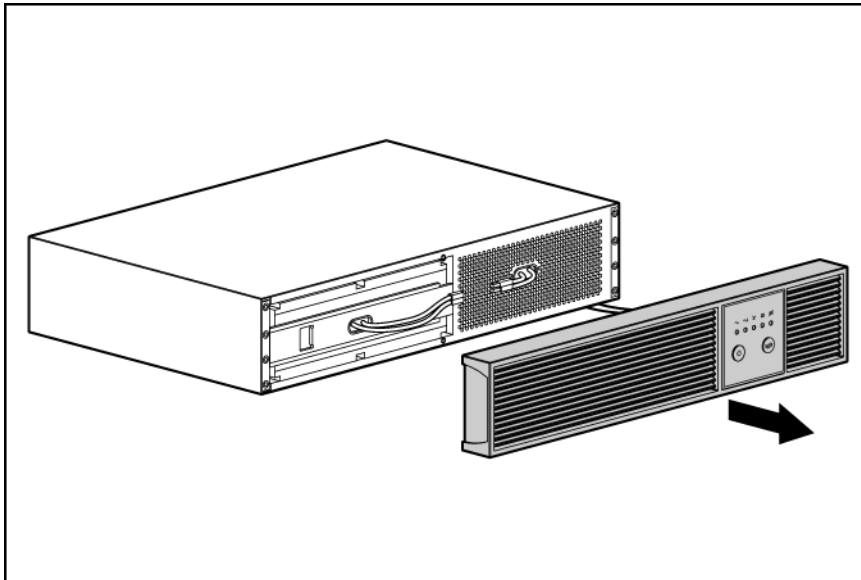

3. Disconnect the battery leads.

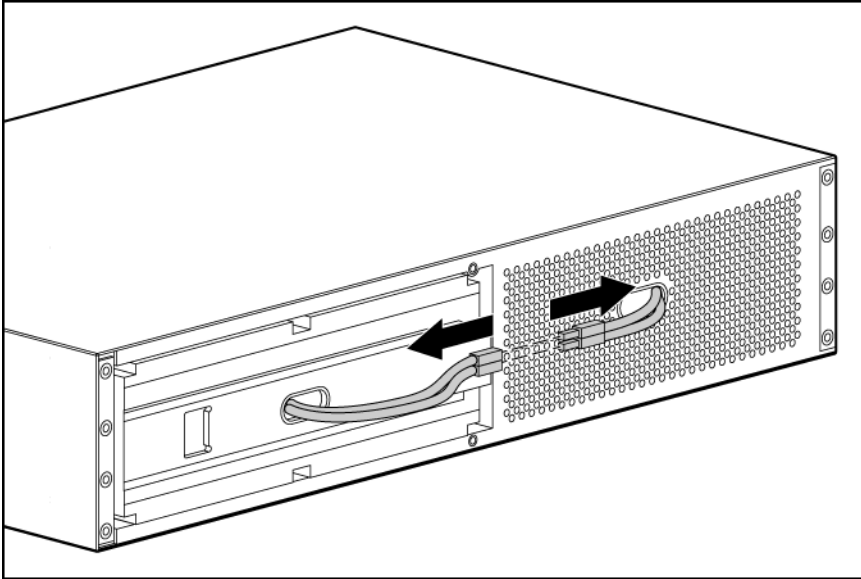

4. Remove the battery bracket.

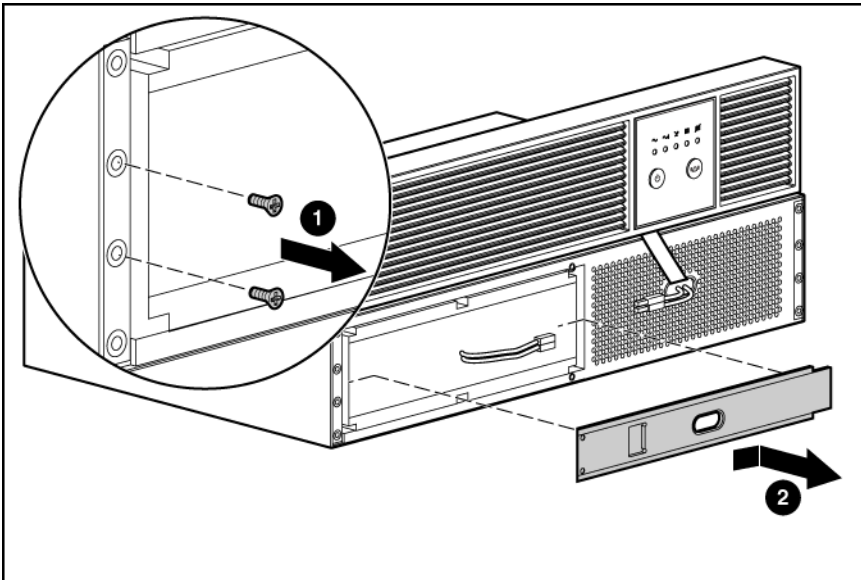

5. Remove the UPS battery modules.



IMPORTANT: Do not pull the battery leads when removing or installing the batteries.

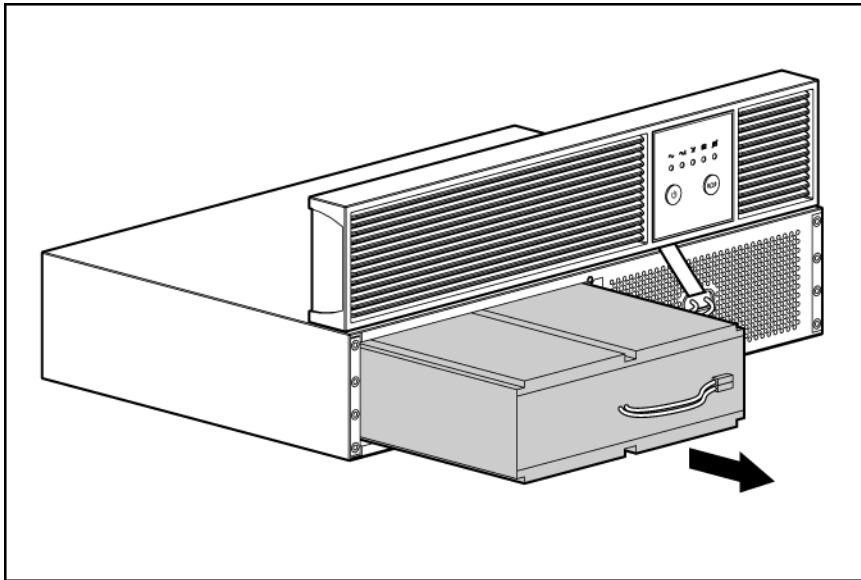

To replace the component, reverse the removal procedure.



IMPORTANT: Charge the batteries for at least 24 hours before supplying backup power to devices. The batteries charge to:

- 90% of their capacity within 4 hours
 - 100% of their capacity within 24 hours
-

Cleaning battery spills

1. Put on acid-resistant boots, a chemical face shield, chemical splash goggles, and acid-resistant gloves.



WARNING: Battery acid can severely damage your eyes and skin.

2. Remove combustible materials and all sources of ignition.
3. Stop the flow of material and contain or absorb small spills with dry sand, earth, or vermiculite.
4. Neutralize spilled battery acid with the special solutions contained in a spill kit or with a solution of 1 lb baking soda to 1 gallon of water.
5. Be sure the mixture is neutral, then collect the residue and place the residue in a drum or other suitable container.
6. Properly dispose of hazardous waste.



WARNING: Do not allow discharge of unneutralized acid to reach the sewer.

Troubleshooting

UPS does not start

Action:

1. Be sure that the power cord is plugged in to a utility power receptacle.
2. Check the power source at the utility power receptacle.
3. Allow the UPS batteries to charge for 24 hours.

UPS does not communicate with the host computer

Action:

Be sure the USB communications port was disconnected before updating the UPS firmware (on page [33](#)).

 **CAUTION:** Using a USB to serial converter cable will damage the UPS.

UPS firmware updating process is interrupted

The serial communications port is disconnected while updating the UPS firmware (on page [33](#)).

Action:

Restart the update.

Audible alarm sounds

Action:

1. Identify the red LED associated with the audible alarm.
2. Check the troubleshooting information in this document to determine the cause of the alarm.

Circuit breaker trips

Action:

Remove some of the load, and then press the circuit breaker to reset the load.

UPS operates on battery only

Action:

1. Save your work.
2. Power down the load devices connected to the UPS output receptacles.
3. Remove one or more load devices to reduce the power requirements.
4. Be sure the UPS configuration matches the utility voltage. Refer to "Selecting the UPS voltage configuration (on page 19)."

UPS frequently switches between utility and battery power

Action:

1. Check the input voltage.
2. Change the power sensitivity adjustment dial ("[Setting the power sensitivity adjustment dial](#)" on page 30) setting.
3. Contact a qualified electrician to verify that the utility power is suitable for the UPS.

UPS does not provide the expected backup time

Action:

1. If the Output Load Level LED is red or flashing red, remove one or more load devices to reduce the power requirements.
2. Power down the UPS ("[Powering down the UPS](#)" on page 31).
3. Verify that the batteries are connected.
4. Allow the UPS batteries to charge for 24 hours.
5. Initiate a self-test ("[Initiating a self-test](#)" on page 30).
6. During extended power outages, save your work, power down the load devices, and then power down the UPS ("[Powering down the UPS](#)" on page 31) to conserve battery power.

UPS emits a slight clicking noise

Action: The UPS is automatically correcting high or low AC voltage on the utility line. No action is required.

Power LED flashes

Action:

If the Battery Charge LED is also red:

- a. Save your work, and power down the UPS ("[Powering down the UPS](#)" on page 31).
- b. After the blackout or brownout is over, power up the UPS ("[Powering up the UPS](#)" on page 24).
- c. Allow the UPS batteries to charge for 24 hours.

If the Battery Charge LED is also yellow or green:

- a. Consider saving your work and powering down the UPS (on page 31). If the blackout or brownout is prolonged, the Battery Charge LED turns red as the UPS batteries near depletion.
- b. After the blackout or brownout is over, power up the UPS ("[Powering up the UPS](#)" on page 24).
- c. Allow the UPS batteries to charge for 24 hours.

Voltage Configuration LED is green

Action: The UPS is automatically correcting high or low AC voltage on the utility line. No action is required.

Output Load Level LED is red or flashing red

Action:

1. Remove one or more load devices to reduce the power requirements.
2. Initiate a self-test ("[Initiating a self-test](#)" on page 30).
3. If the condition persists, verify that the load devices are not defective.

Battery Charge LED is red

Action:

If the Power LED is flashing green:

- a. Save your work, and power down the UPS ("[Powering down the UPS](#)" on page 31).
- b. After the blackout or brownout is over, power up the UPS ("[Powering up the UPS](#)" on page 24).
- c. Allow the UPS batteries to charge for 24 hours.

If the Power LED is green:

- a. Continue to let the batteries charge until the Battery Charge LED is green.
- b. Initiate a self-test ("[Initiating a self-test](#)" on page 30).

Specifications

UPS physical specifications

Parameter	Value
Height	8.9 cm (3.5 in)
Depth	48.3 cm (19 in)
Width	44.5 cm (17.5 in)
Weight	29 kg (64 lb)

ERM physical specifications

Parameter	Value
Height	8.9 cm (3.5 in)
Depth	34.3 cm (13.5 in)
Width	44.5 cm (17.5 in)
Weight	28.6 kg (63 lb)

UPS input specifications

NOTE: An asterisk (*) indicates the default setting.

UPS model	Utility voltage frequency (Hz)	Available settings utility voltage (VAC)	Branch circuit rating (A)	Line cord
R/T2200 NA/JPN/TWN	50/60	100, 110, 120*	20	Nondetachable power cord with NEMA 5-20 plug
R/T2200 INTL	50/60	220, 230*, 240	15	Detachable power cord with IEC-320-C20 plug

UPS output specifications

UPS model	Output receptacles	Maximum current
R/T2200 NA/JPN/TWN	4 x NEMA 5-15R, 4 x NEMA 5-15/20R	18.3 A
R/T2200 INTL	8 x IEC-320-C13	9.5 A

Power protection specifications

UPS model	VA	Nominal power rating (W)	Nominal voltage setting
R/T2200 NA/JPN/TWN	2200	1600	100, 110, 120
R/T2200 INTL	2200	1600	220, 230, 240

Voltage specifications

Configuration setting (VAC)	Available nominal output voltage (VAC)
100	100
110	110
120	120
220	220
230	230
240	240

Output tolerance specifications

Source of power	Regulation
Utility power (nominal range)	-10% to +6% of nominal output voltage rating (within the guidelines of the Computer Business Equipment Manufacturers Association)
Battery power	±10% of nominal output voltage rating

Output feature specifications

Feature	Specification
Online efficiency	95% nominal input voltage
Voltage wave shape	Sine wave; 5% THD with typical PFC load
Surge suppression	High-energy 6500 A peak
Noise filtering	MOVs and line filter for normal and common mode use

Battery specifications

Feature	Specification
Type	12 V, 9 AH, sealed, maintenance-free, rechargeable, lead-acid battery
Voltage	The battery modules have a battery string voltage of 48 V.

Feature	Specification
Charging	Complete charge takes no more than 24 hours. After approximately 4 hours, the batteries reach 90% charge at default nominal utility voltage and no load.

Battery runtime

Load, percent	Load, watts	Estimated battery runtime	Runtime with an ERM
20	100	45 minutes	150 minutes
50	250	15 minutes	60 minutes
80	400	8.5 minutes	30 minutes
100	500	6 minutes	20 minutes

Environmental specifications

Feature	Specification
Operating temperature	0°C to 40°C (32°F to 104°F)
Nonoperating temperature	-15°C to 50°C (5°F to 122°F)
Relative humidity	0% to 95%; noncondensing
Operating altitude	Up to 2,000 m (6,600 ft) above sea level
Nonoperating altitude	Up to 15,000 m (49,212 ft) above sea level
Audible noise	Less than 53 dBA

Spares

Ordering spares

To order a spare, visit the HP website (<http://h61003.www6.hp.com>).

To replace parts under warranty, contact an HP authorized service representative.

Spare parts list

Item	Spare part number
UPS unit NA	410039-001
UPS unit JPN/TWN	410040-291
UPS unit INTL	410041-B31
ERM unit	410045-001
UPS/ERM tower stand	410042-001
UPS/ERM mounting hardware	415694-001
UPS battery	416727-001

Hardware options

For information on the supported hardware options, see the HP website (<http://www.hp.com/go/rackandpower>).

Technical support

Before you contact HP

Be sure to have the following information available before you call HP:

- Technical support registration number (if applicable)
- Product serial number
- Product model name and number
- Product identification number
- Applicable error messages
- Add-on boards or hardware
- Third-party hardware or software
- Operating system type and revision level

HP contact information

For the name of the nearest HP authorized reseller:

- In the United States, see the HP US service locator webpage (http://www.hp.com/service_locator).
- In other locations, see the Contact HP worldwide (in English) webpage (<http://welcome.hp.com/country/us/en/wwcontact.html>).

For HP technical support:

- In the United States, for contact options see the Contact HP United States webpage (http://welcome.hp.com/country/us/en/contact_us.html). To contact HP by phone:
 - Call 1-800-HP-INVENT (1-800-474-6836). This service is available 24 hours a day, 7 days a week. For continuous quality improvement, calls may be recorded or monitored.
 - If you have purchased a Care Pack (service upgrade), call 1-800-633-3600. For more information about Care Packs, refer to the HP website (<http://www.hp.com>).
- In other locations, see the Contact HP worldwide (in English) webpage (<http://welcome.hp.com/country/us/en/wwcontact.html>).

Warranty information

Limited warranty

To back up the wide range of features offered with the UPS, a 3-year limited warranty is provided.

\$250,000 Computer Load Protection Guarantee

In addition to the limited warranty, a \$250,000 Computer Load Protection Guarantee (provided by the original equipment manufacturer) is offered.



IMPORTANT: The \$250,000 Computer Load Protection Guarantee is offered only in The United States and Canada.

The \$250,000 Computer Load Protection Guarantee only applies if:

- The UPS is plugged into a suitably grounded and wired outlet using no extension cords, adapters, other ground wires, or other electrical connections.
- The UPS installation complies with all applicable electrical and safety codes specified by the NEC.
- The UPS is used under normal operating conditions and users comply with all instructions and labels.
- The UPS is not damaged by accident (other than a utility power transient), misuse, or abuse.
 - The Guarantee applies only to the original end-user and is non-transferable.
 - The Guarantee does not include reimbursement for or restoration of any data loss.
- The UPS is either connected directly to an enterprise class PDU, which is then connected directly to a server, workstation, or personal computer, or the UPS is connected directly to a server, workstation, or personal computer.

Pre-Failure Battery Warranty

The Pre-Failure Battery Warranty, standard on all UPS units, extends the advantage of a 3-year limited warranty by applying it to the battery before it actually fails. The Pre-Failure Battery Warranty ensures that the battery is replaced free of charge when a notification that the battery might fail is received from power management software. The battery warranty coverage is 3 years for parts. The warranty for the first year of ownership includes parts and labor. If battery spares are not available for a particular UPS model, the entire UPS, including its battery, is replaced.

A Pre-Failure Battery warning is given 30 days before a battery failure. The warning is indicated in one or both of the following ways:

- An LED showing the battery is low
- Notification from power management software

Regulatory compliance notices

Regulatory compliance identification numbers

For the purpose of regulatory compliance certifications and identification, this product has been assigned a unique regulatory model number. The regulatory model number can be found on the product nameplate label, along with all required approval markings and information. When requesting compliance information for this product, always refer to this regulatory model number. The regulatory model number is not the marketing name or model number of the product.

Federal Communications Commission notice

Part 15 of the Federal Communications Commission (FCC) Rules and Regulations has established Radio Frequency (RF) emission limits to provide an interference-free radio frequency spectrum. Many electronic devices, including computers, generate RF energy incidental to their intended function and are, therefore, covered by these rules. These rules place computers and related peripheral devices into two classes, A and B, depending upon their intended installation. Class A devices are those that may reasonably be expected to be installed in a business or commercial environment. Class B devices are those that may reasonably be expected to be installed in a residential environment (for example, personal computers). The FCC requires devices in both classes to bear a label indicating the interference potential of the device as well as additional operating instructions for the user.

FCC rating label

The FCC rating label on the device shows the classification (A or B) of the equipment. Class B devices have an FCC logo or ID on the label. Class A devices do not have an FCC logo or ID on the label. After you determine the class of the device, refer to the corresponding statement.

Class A equipment

This equipment has been tested and found to comply with the limits for a Class A digital device, pursuant to Part 15 of the FCC Rules. These limits are designed to provide reasonable protection against harmful interference when the equipment is operated in a commercial environment. This equipment generates, uses, and can radiate radio frequency energy and, if not installed and used in accordance with the instructions, may cause harmful interference to radio communications. Operation of this equipment in a residential area is likely to cause harmful interference, in which case the user will be required to correct the interference at personal expense.

Class B equipment

This equipment has been tested and found to comply with the limits for a Class B digital device, pursuant to Part 15 of the FCC Rules. These limits are designed to provide reasonable protection against harmful interference in a residential installation. This equipment generates, uses, and can radiate radio frequency

energy and, if not installed and used in accordance with the instructions, may cause harmful interference to radio communications. However, there is no guarantee that interference will not occur in a particular installation. If this equipment does cause harmful interference to radio or television reception, which can be determined by turning the equipment off and on, the user is encouraged to try to correct the interference by one or more of the following measures:

- Reorient or relocate the receiving antenna.
- Increase the separation between the equipment and receiver.
- Connect the equipment into an outlet on a circuit that is different from that to which the receiver is connected.
- Consult the dealer or an experienced radio or television technician for help.

Declaration of conformity for products marked with the FCC logo, United States only

This device complies with Part 15 of the FCC Rules. Operation is subject to the following two conditions: (1) this device may not cause harmful interference, and (2) this device must accept any interference received, including interference that may cause undesired operation.

For questions regarding this product, contact us by mail or telephone:

- Hewlett-Packard Company
P. O. Box 692000, Mail Stop 530113
Houston, Texas 77269-2000
- 1-800-HP-INVENT (1-800-474-6836). (For continuous quality improvement, calls may be recorded or monitored.)

For questions regarding this FCC declaration, contact us by mail or telephone:

- Hewlett-Packard Company
P. O. Box 692000, Mail Stop 510101
Houston, Texas 77269-2000
- 1-281-514-3333

To identify this product, refer to the part, series, or model number found on the product.

Modifications

The FCC requires the user to be notified that any changes or modifications made to this device that are not expressly approved by Hewlett-Packard Company may void the user's authority to operate the equipment.

Cables

Connections to this device must be made with shielded cables with metallic RFI/EMI connector hoods in order to maintain compliance with FCC Rules and Regulations.

Canadian notice (Avis Canadien)

Class A equipment

This Class A digital apparatus meets all requirements of the Canadian Interference-Causing Equipment Regulations.

Cet appareil numérique de la classe A respecte toutes les exigences du Règlement sur le matériel brouilleur du Canada.

Class B equipment

This Class B digital apparatus meets all requirements of the Canadian Interference-Causing Equipment Regulations.

Cet appareil numérique de la classe B respecte toutes les exigences du Règlement sur le matériel brouilleur du Canada.

European Union regulatory notice

This product complies with the following EU Directives:

- Low Voltage Directive 2006/95/EC
- EMC Directive 2004/108/EC

Compliance with these directives implies conformity to applicable harmonized European standards (European Norms) which are listed on the EU Declaration of Conformity issued by Hewlett-Packard for this product or product family.

This compliance is indicated by the following conformity marking placed on the product:



This marking is valid for non-Telecom products and EU harmonized Telecom products (e.g. Bluetooth).



This marking is valid for EU non-harmonized Telecom products.

*Notified body number (used only if applicable—refer to the product label)

Hewlett-Packard GmbH, HQ-TRE, Herrenberger Strasse 140, 71034 Boeblingen, Germany

Disposal of waste equipment by users in private households in the European Union



This symbol on the product or on its packaging indicates that this product must not be disposed of with your other household waste. Instead, it is your responsibility to dispose of your waste equipment by handing it over to a designated collection point for the recycling of waste electrical and electronic equipment. The separate collection and recycling of your waste equipment at the time of disposal will help to conserve natural resources and ensure that it is recycled in a manner that protects human health and the environment. For more information about where you can drop off your waste equipment for recycling, please contact your local city office, your household waste disposal service or the shop where you purchased the product.

Japanese notice

ご使用になっている装置にVCCIマークが付いていましたら、次の説明文をお読み下さい。

この装置は、情報処理装置等電波障害自主規制協議会（VCCI）の基準に基づくクラスB情報技術装置です。この装置は、家庭環境で使用することを目的としていますが、この装置がラジオやテレビジョン受信機に近接して使用されると、受信障害を引き起こすことがあります。

取扱説明書に従って正しい取り扱いをして下さい。

VCCIマークが付いていない場合には、次の点にご注意下さい。

この装置は、情報処理装置等電波障害自主規制協議会（VCCI）の基準に基づくクラスA情報技術装置です。この装置を家庭環境で使用すると電波妨害を引き起こすことがあります。この場合には使用者が適切な対策を講ずるよう要求されることがあります。

BSMI notice

警告使用者:

這是甲類的資訊產品，在居住的環境中使用時，可能會造成射頻干擾，在這種情況下，使用者會被要求採取某些適當的對策。

Korean notice

Class A equipment

A급 기기 (업무용 방송통신기기)	이 기기는 업무용(A급)으로 전자파적합등록을 한 기기이오니 판매자 또는 사용자는 이 점을 주의하시기 바라며, 가정 외의 지역에서 사용하는 것을 목적으로 합니다.
-----------------------	---

Class B equipment

B급 기기 (가정용 방송통신기기)	이 기기는 가정용(B급)으로 전자파적합등록을 한 기기로서 주로 가정에서 사용하는 것을 목적으로 하며, 모든 지역에서 사용할 수 있습니다.
-----------------------	--

Battery replacement notice



WARNING: Power products contain sealed lead-acid battery modules. A risk of fire and burns exists if the battery is not properly handled. To reduce the risk of personal injury:

- Do not attempt to recharge the battery.
- Do not expose the battery to temperatures higher than 60°C (140°F).
- Do not disassemble, crush, puncture, short external contacts, or dispose of in fire or water. The battery might explode.



Batteries, battery packs, and accumulators should not be disposed of together with the general household waste. To forward them to recycling or proper disposal, use the public collection system or return them to HP, an authorized HP Partner, or their agents.

For more information about battery replacement or proper disposal, contact an authorized reseller or an authorized service provider.

Power cord statement for Japan

製品には、同梱された電源コードをお使い下さい。
同梱された電源コードは、他の製品では使用出来ません。

Electrostatic discharge

Preventing electrostatic discharge

To prevent damaging the system, be aware of the precautions you need to follow when setting up the system or handling parts. A discharge of static electricity from a finger or other conductor may damage system boards or other static-sensitive devices. This type of damage may reduce the life expectancy of the device.

To prevent electrostatic damage:

- Avoid hand contact by transporting and storing products in static-safe containers.
- Keep electrostatic-sensitive parts in their containers until they arrive at static-free workstations.
- Place parts on a grounded surface before removing them from their containers.
- Avoid touching pins, leads, or circuitry.
- Always be properly grounded when touching a static-sensitive component or assembly.

Grounding methods to prevent electrostatic discharge

Several methods are used for grounding. Use one or more of the following methods when handling or installing electrostatic-sensitive parts:

- Use a wrist strap connected by a ground cord to a grounded workstation or computer chassis. Wrist straps are flexible straps with a minimum of 1 megohm ± 10 percent resistance in the ground cords. To provide proper ground, wear the strap snug against the skin.
- Use heel straps, toe straps, or boot straps at standing workstations. Wear the straps on both feet when standing on conductive floors or dissipating floor mats.
- Use conductive field service tools.
- Use a portable field service kit with a folding static-dissipating work mat.

If you do not have any of the suggested equipment for proper grounding, have an authorized reseller install the part.

For more information on static electricity or assistance with product installation, contact an authorized reseller.

Acronyms and abbreviations

EPO

emergency power off

ERM

extended runtime module

HPPM

Hewlett-Packard Power Manager

IEC

International Electrotechnical Commission

LED

light-emitting diode

NEC

National Electrical Code

NEMA

National Electrical Manufacturers Association

PFC

power factor corrected

REPO

remote emergency power off

RETMA

Radio Electronics Television Manufactures Association (rack spacing)

UPS

uninterruptible power system

USB

universal serial bus

Index

A

alarm conditions 30
alarms, silencing 30
authorized reseller 44

B

backup time, insufficient 38
batteries, care and storage 34
batteries, charging 24, 29
batteries, cleaning spills 36
batteries, connecting 18
batteries, replacing 33, 34
batteries, runtime 42
batteries, specifications 41
battery cables, connecting 18
Battery Charge LED, location 7
Battery Charge LED, troubleshooting 39
battery replacement notice 50
Battery Warning LED, location 7
battery warranty 45
bezel, front 6
bezel, removing 13, 24, 34
BSMI notice 49

C

cables 47
cables, battery 18
cabling, USB 21
Canadian notice 48
charging batteries 24, 29
circuit breaker, troubleshooting 37
circuit breakers, location 8, 9
class A equipment 46
class B equipment 46
communications port, connecting 21
component identification 6, 7, 8, 9
components, rear 8, 9
configuring components 19
connecting batteries 18
contacting HP 44

D

diagnostics 30
dimensions, ERM 40
dimensions, UPS 40
DIP switches, location 8, 9
DIP switches, setting 19
disposal, battery 50

E

electrostatic discharge 51
environmental specifications 42
ERM, connecting 28
ERM, R/T2200 24

F

FCC rating label 46
Federal Communications Commission (FCC)
notice 46, 47
frequent switching between battery and utility
power 38
front bezel 6
front panel buttons 7
front panel components 6, 7
front panel LEDs 7

G

ground bonding cable, connecting 23
ground bonding screw, location 8, 9
grounding methods 51

H

hardware options 43
HP technical support 44

I

input circuit breaker, location 8, 9
input specifications 40
installation instructions 12, 13, 24
installing the ERM 24
installing the UPS 13

insufficient backup time 38
International model 9

J

Japanese notice 49

L

LED, power button 7
LEDs 6, 7
LEDs, troubleshooting 37
limited warranty 45
load protection guarantee 45
load segments, location 8, 9
low-voltage UPS 8

M

maintenance 33
models, high-voltage UPS 9
models, low-voltage UPS 8
modifications, FCC notice 47
Mute/Test button 7

N

nominal voltage, configuring 19
North America and Japan model 8

O

On button, location 7
operations, UPS 30
ordering spares 43
output feature specifications 41
Output Load Level LED, location 7
Output Load Level LED, troubleshooting 39
output specifications 40
output tolerance specifications 41
overview, front panel display 7
overview, REPO port 10

P

phone numbers 44
physical specifications 40
power LED, location 7
Power LED, troubleshooting 38
power management 32
Power On/Standby button 7
power protection specifications 41
power sensitivity adjustment dial, location 8, 9

power sensitivity adjustment dial, setting 30
powering down 31
powering up 24
problem diagnosis 37

R

R/T2200 INTL 7, 9
R/T2200 NA/JPN/TWN 7, 8
rack-to-tower conversion 13, 24
rear panel components 8, 9
regulatory compliance identification numbers 46
regulatory compliance notices 46, 48
replacing the batteries 33, 34
REPO port, connecting 22
REPO port, overview 10
required information 44
required tools 12
resetting the circuit breaker 8, 10, 37
runtime specifications 42

S

safety considerations 12
selecting a site 12
serial port 21
series number 46
spare part numbers 43
spares 43
specifications 40
Standby button, location 7
Standby mode 7
static electricity 51
storing batteries 34
supported hardware 43

T

technical support 44
telephone numbers 44
temperature ranges (environmental) 42
testing LEDs 30
tower to rack conversion 13, 24
troubleshooting 37

U

Uninterruptible Power System, high-voltage models 9
Uninterruptible Power System, low-voltage models 8
UPS does not start 37
UPS operations 30

UPS, installing 12, 13

USB connectors 21

V

Voltage Correction LED, location 7

Voltage Correction LED, troubleshooting 39

voltage specifications 41

voltage, configuring 19

W

warranties 45

weight, ERM 40

weight, UPS 40